

* **Tasks, problems and
real South African project**



Masaryk University

Faculty of Economics and Administration,

Department of Corporate Economy

Ing. J. Skorkovský, CSc.



*Your main task (not organised set of processes)

Load-despatch	Purchase Order	Reporting	Statistics
Consumption registration	Production Output registration	Inventory value calculation	Output check
Delivery	Production Planning	Sales Order	Component replenishment
Transfer to Production	Put-away	Cross-docking	Input check
Finished goods to Inventory	Picking from Inventory	Invoicing	Payment

*Your main task (organised set of processes)

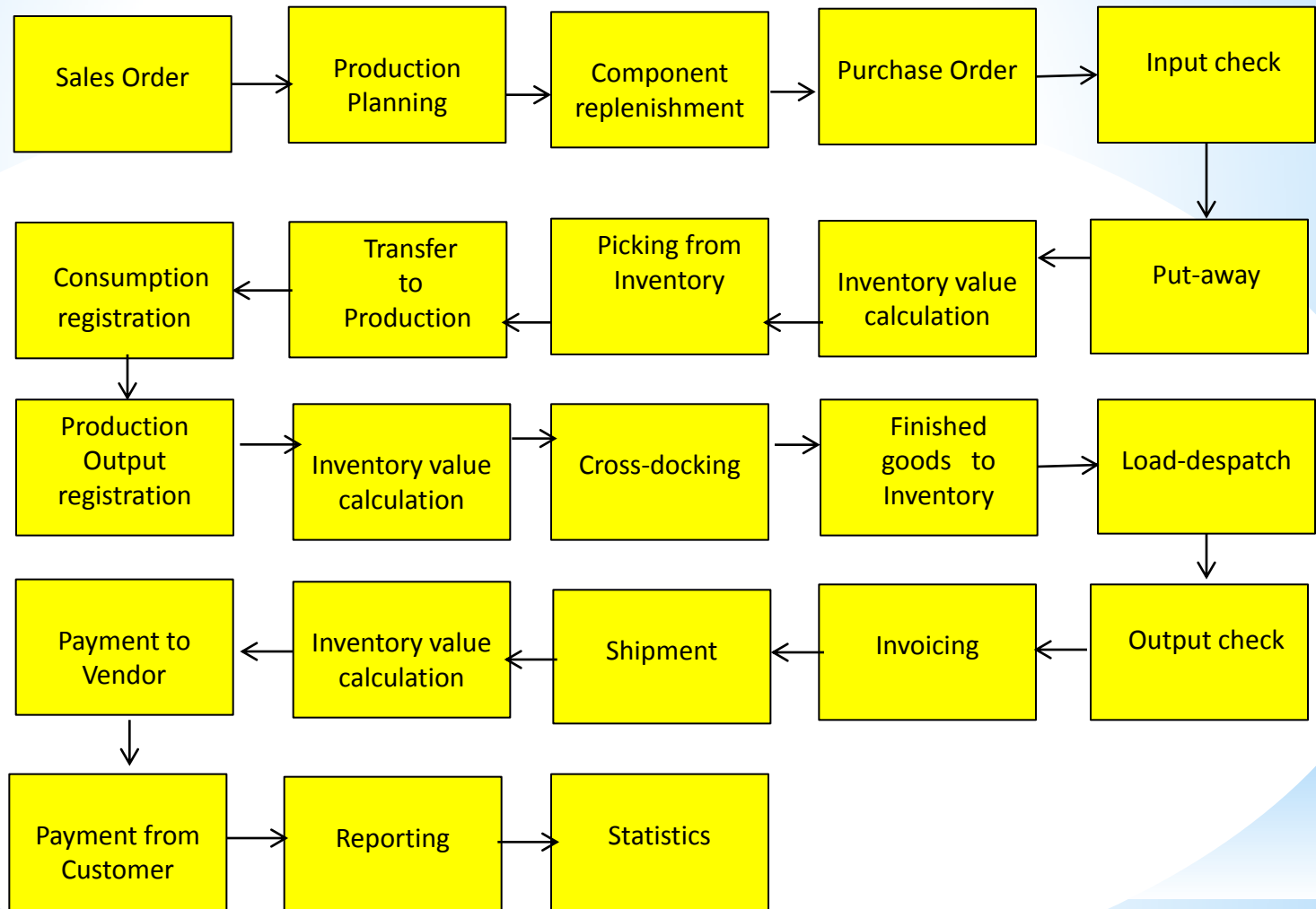

*Your main task (possible problems, bottlenecks,..)

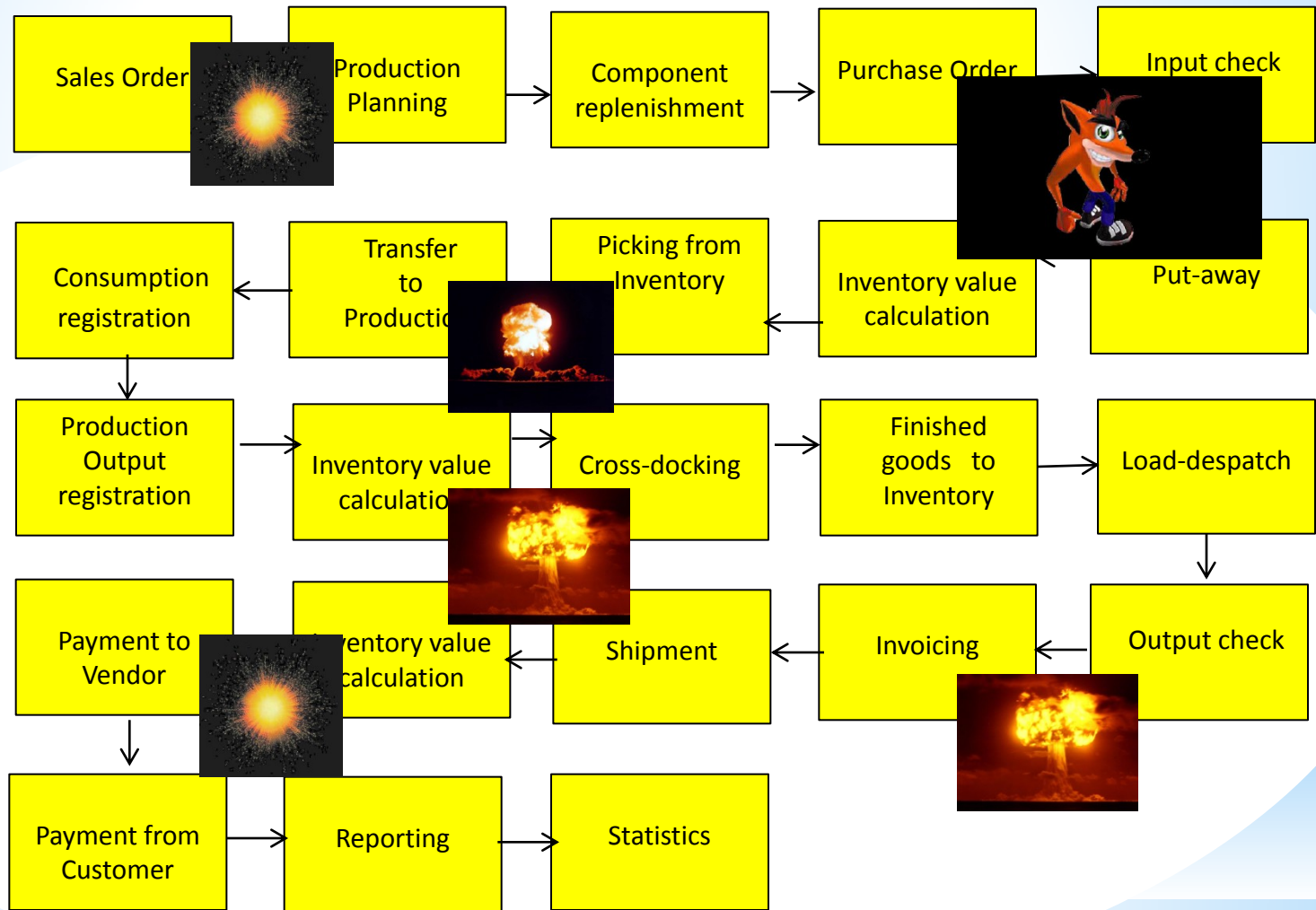

*Your main task

Search - **HOW** ??? Measure impacts -**HOW** ??? and Destroy - **HOW** ??? And improve - **HOW** ???

CAUSE->EFFECT RELATIONS

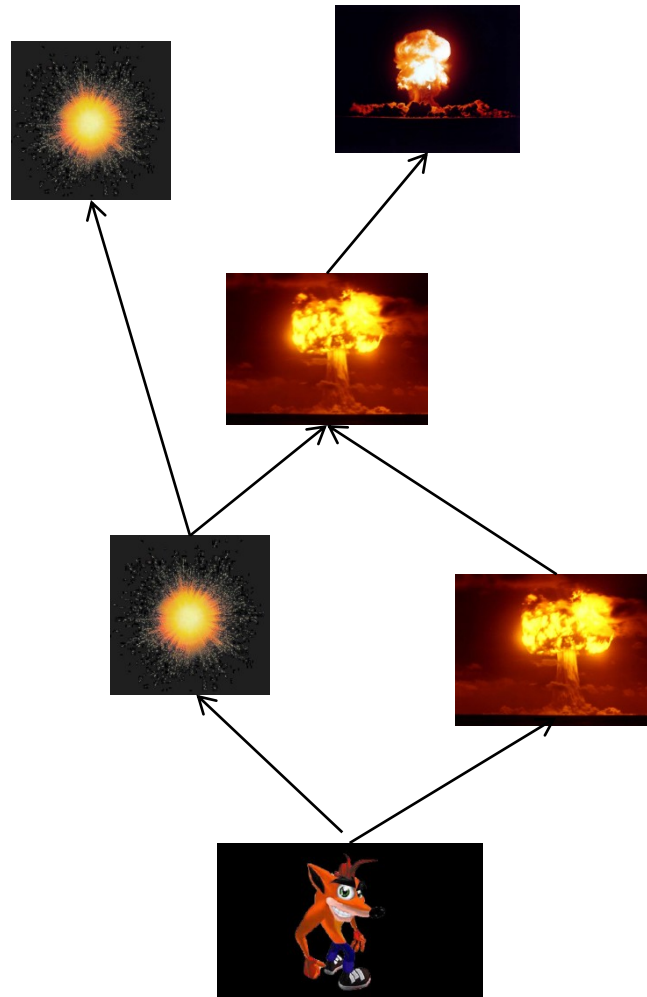

* Methods (not sorted so far)

- * Theory of Constraints
- * Critical Chain (DBR)
- * Ishikawa Fishbone Diagram (Total Quality Management)
- * Pareto Analysis , ABC, EOQ, Six Sigma and Ishikawa
- * OLAP (On-Line Analytic Processing)
- * Kepner –Tregoe methodology
- * MaxMax and MaxMin (Hurwitz)
- * SWOT, BOSTON and Gartner Magic matrices
- * ERP Statistics and Reporting
- * Little’s law
- * Yield Management
- * Linear programming
- * Balanced Scorecard
- * Production algorithms (MRP,MRP-II, JIT,APS)
- * And many, many more.....

BS and OM - slide from Balanced Scorecard show (will be presented again in BS context)

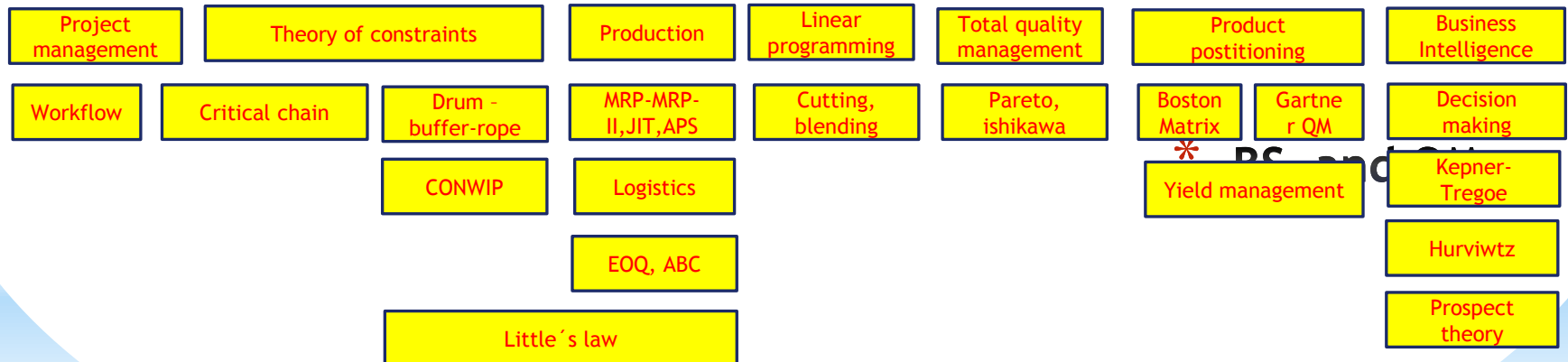

* Simplified diagram of ERP usage

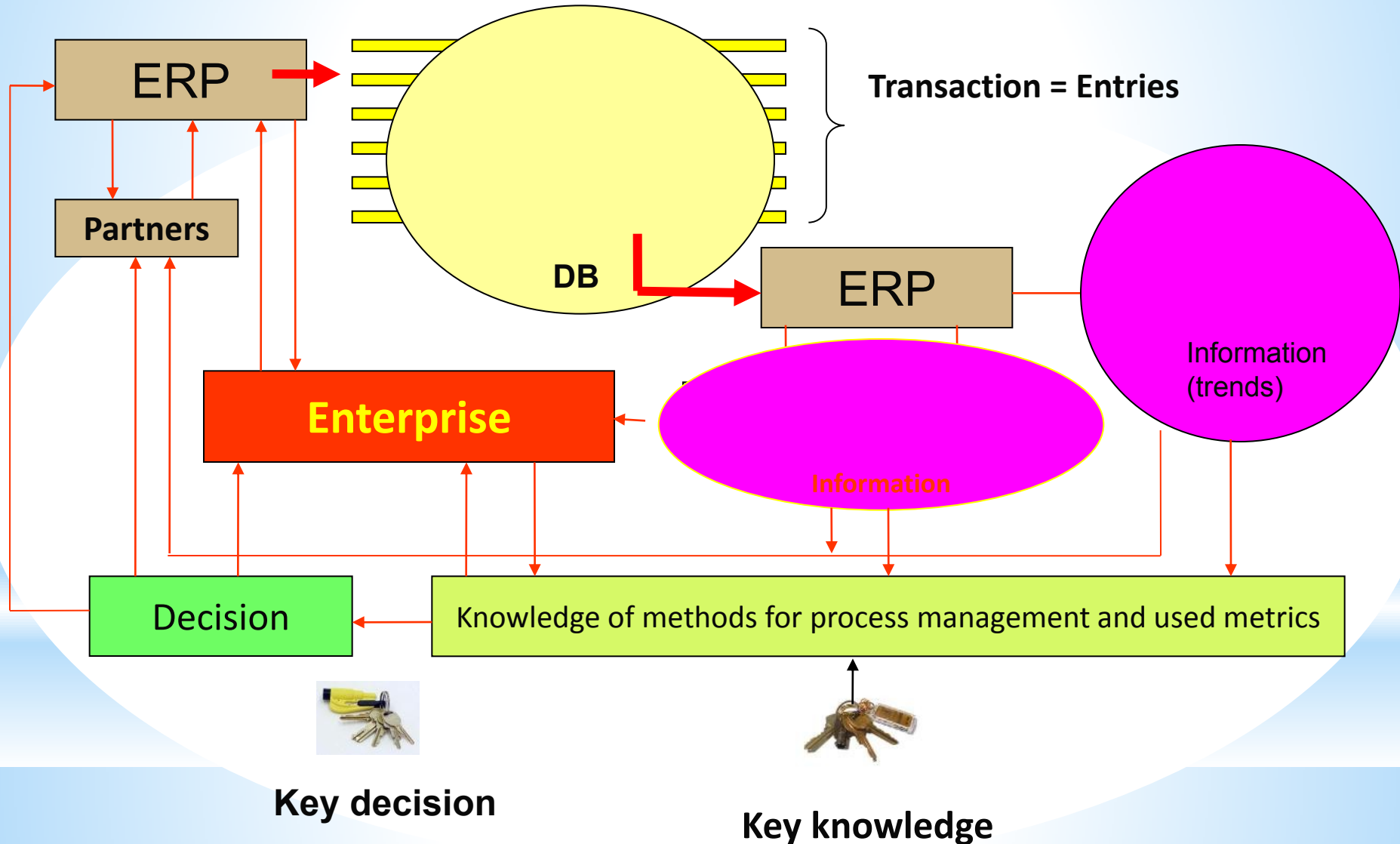

* Basic problem I. (one of many)



We have a huge data quantity



..and at the same time a minimum information which could be used for **decision making !!!!**



* Basic problem II. (we need reliable data)

To solve it we should use finite capacity scheduling (APS)- will be presented later

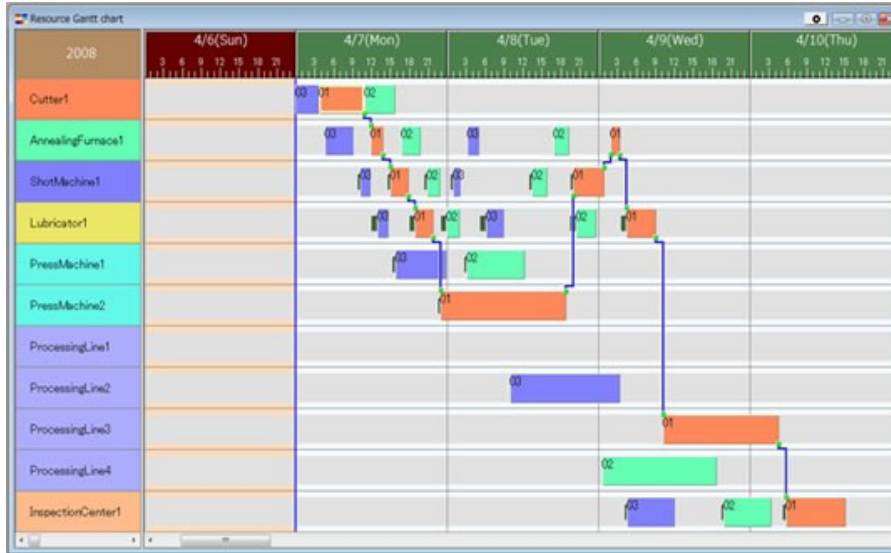

$$T1+T2=X$$

$$Opt=Min(X)$$

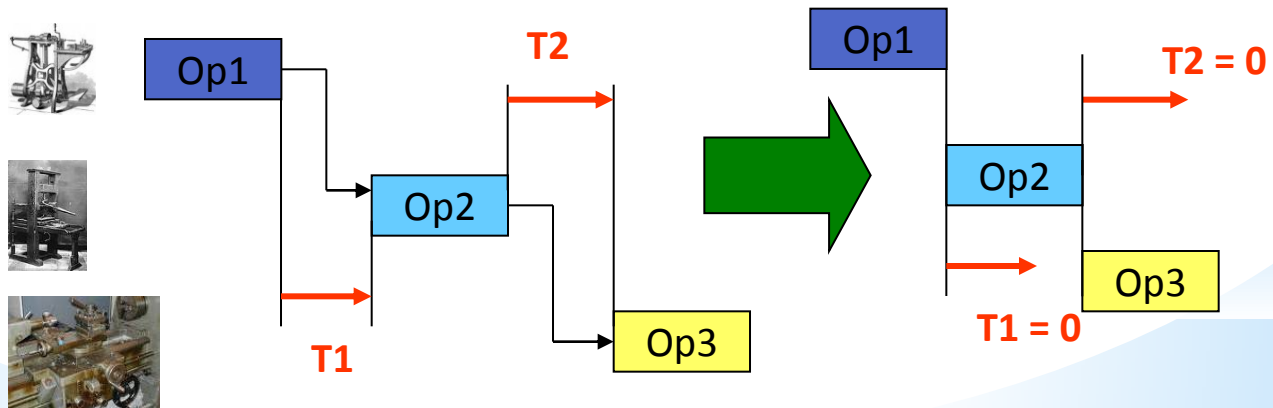

* Basic problem III.

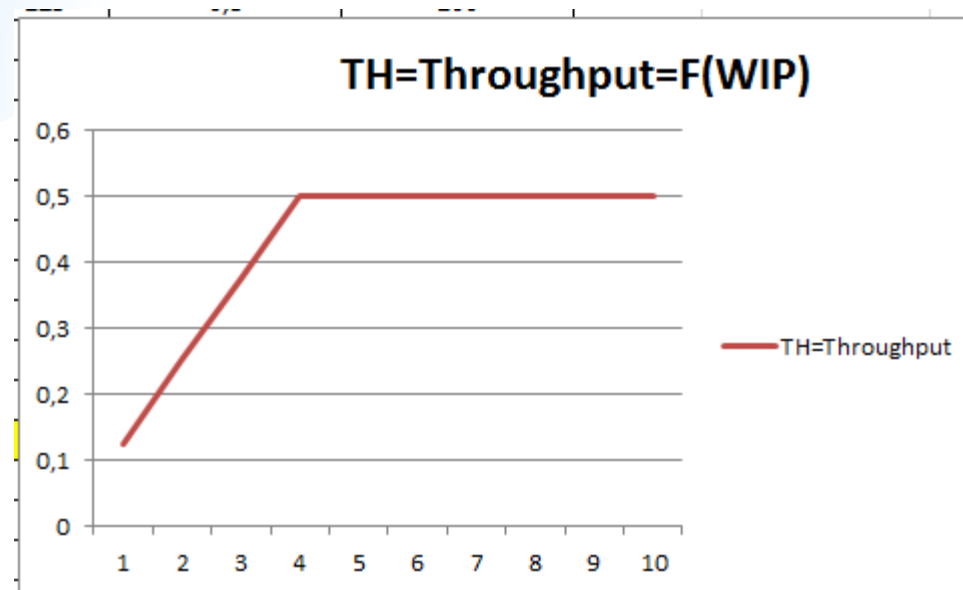

Will be explained in Little's law presentation

*Basic problem IV.

Black

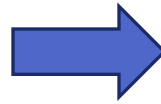

White

White

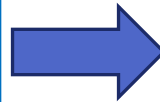

Black

(Black ->White, Setup time=60 minut)

(White->Black, Setup time = 20 minut)

* Basic problem V-I. (availability of components)

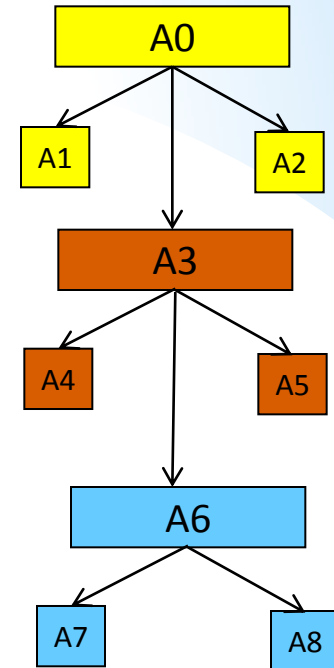
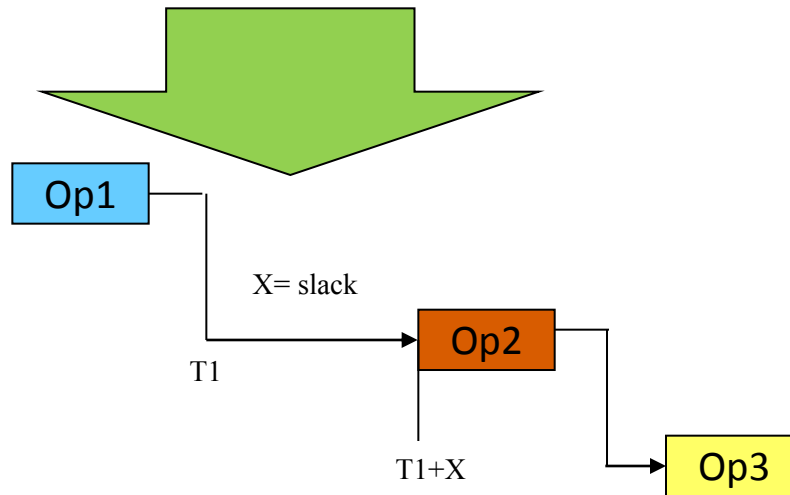
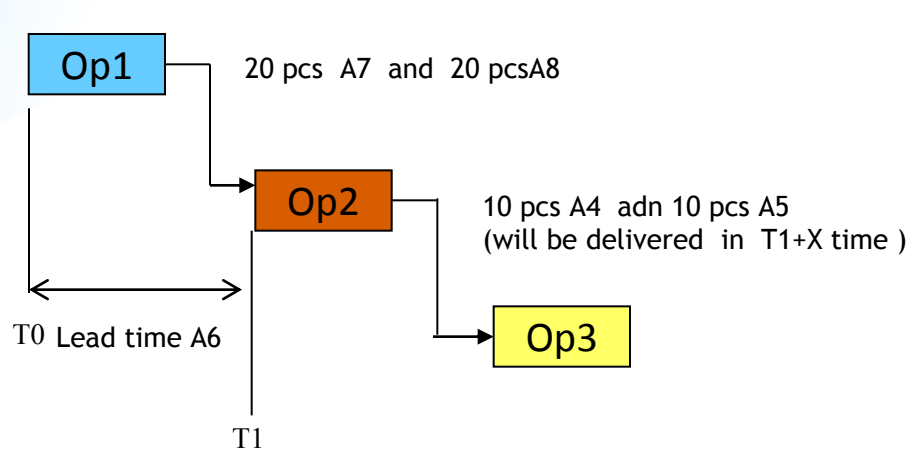

* Basic problem V-II.

(availability of components)

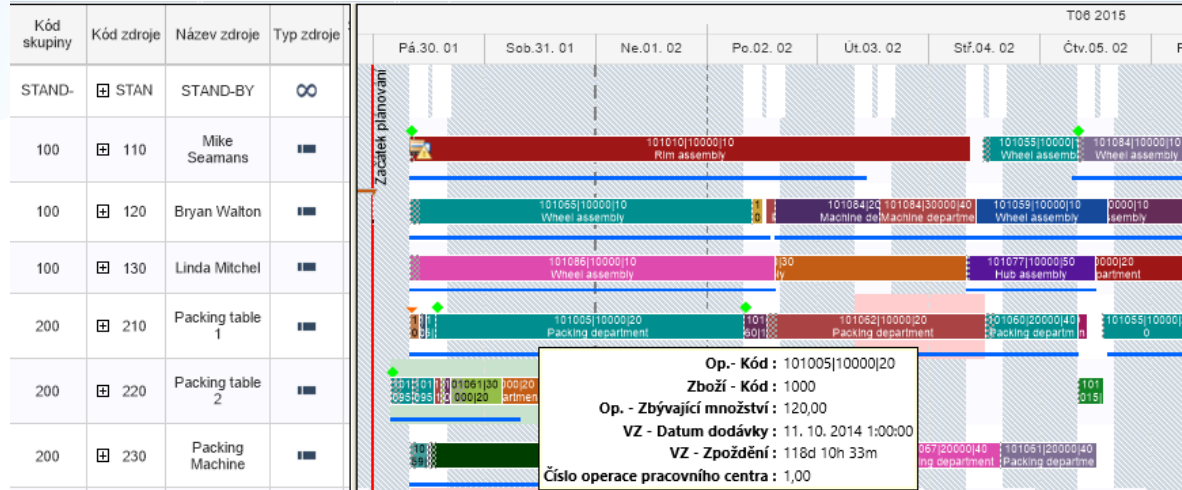

Prod. Order Routing

Type to filter (F3) Prod. Order No.

Filter: Firm Planned • 101005 • 10000 • 10

Operati... No.	Type	No.	Description	Starting Date-Time	Ending Date-Time	Setup Time	Run Time	Material Fixed Date
10	Work Center	100	Wheel assembly	18. 8. 2014 14:41	22. 8. 2014 8:31	110	12	23. 8. 2014 0:00
20	Work Center	200	Packing department	27. 8. 2014 8:31	1. 9. 2014 14:46	15	15	10. 9. 2014 0:00
30	Work Center	300	Painting department	1. 9. 2014 14:46	4. 9. 2014 10:46	10	20	
40	Work Center	400	Machine department	4. 9. 2014 11:11	5. 9. 2014 12:21	10	8	

APS result ->18.8.->23.8. a 27.8.->10.9

* Basic problem VI-I.

(over budget)

2012 - Budget

General Filters Options

Budget Name 2012 ↑

Show as Lines G/L Account ↑

Show as Columns Period ↑

Code	Name	Budgeted Amount	26.03.12	02.04.12
8100	Building Maintenance Expenses			
▶ 8110	Cleaning	1 160,00	1 000,00	
8120	Electricity and Heating	1 120,00	1 000,00	
8130	Repairs and Maintenance	1 160,00	1 000,00	
8190	Total Bldg. Maint. Expenses	3 440,00	3 000,00	
8200	Administrative Expenses			
8210	Office Supplies	510,00	500,00	
8230	Phone and Fax	800,00	800,00	
8240	Postage	1 390,00	1 200,00	
8290	Total Administrative Expenses	2 700,00	2 500,00	
8300	Computer Expenses			
8310	Software	1 000,00	1 000,00	

1 7 31 3 12 ⋮ ⏪ ⏩ Balance ▾ Functions ▾ Help

* Basic problem VI-II. (over budget)

1015 London Postmaster - Purchase Invoice

General Invoicing Shipping Foreign Trade E-Commerce

No. 1015

Buy-from Vendor No. 10000

Buy-from Contact No. CT000066

Buy-from Vendor Name London Postmaster

Buy-from Address 10 North Lake Avenue

Buy-from Address 2

Buy-from Post Code/City N12 5XY London

Buy-from Contact Mrs. Carol Philips

Posting Date 26.03.12

Document Date 26.03.12

Vendor Invoice No. Miki-0983

Order Address Code.

Purchaser Code RL

Campaign No.

Responsibility Center LONDON

Assigned User ID

Status Open

Type	No.	Description	Location Code	Quantity	Unit of Measure ...	Direct Unit Cost Excl...	Line Amount Excl. VAT	Line Disco...	Qty. to Assign
G/L Ac...	8110	Cleaning		10	HOUR	100,00	1 000,00		
G/L Ac...	8120	Electricity and Heating		20	HOUR	200,00	4 000,00		
G/L Ac...	8130	Repairs and Maintenance		30	HOUR	300,00	9 000,00		
G/L Ac...	8210	Office Supplies		10	HOUR	100,00	1 000,00		
G/L Ac...	8230	Phone and Fax		20	HOUR	200,00	4 000,00		
▶ G/L Ac...	8240	Postage		30	HOUR	300,00	9 000,00		

Invoice Line Functions Posting Help

* Basic problem VI-III. (over budget)

G/L Balance/Budget

Options

Date Filter 01.03.12..31.03.12 Budget Filter 2012

Department Filter Closing Entries Include

Project Filter

No.	Name	I... Debit Amount	Credit Amount	Balance/Budget (%)	Budgeted Debit Amount	Budgeted Credit Amount	Budgeted Amount
8100	Building Maintenance Expenses	L...					
▶ 8110	Cleaning	I... 1 000,00		100,0	1 000,00		1 000,00
8120	Electricity and Heating	I... 4 000,00		400,0	1 000,00		1 000,00
8130	Repairs and Maintenance	I... 9 000,00		900,0	1 000,00		1 000,00
8190	Total Bldg. Maint. Expenses	L... 14 000,00		466,7	3 000,00		3 000,00
8200	Administrative Expenses	L...					
8210	Office Supplies	I... 1 000,00		200,0	500,00		500,00
8230	Phone and Fax	I... 4 000,00		500,0	800,00		800,00
8240	Postage	I... 9 000,00		750,0	1 200,00		1 200,00
8290	Total Administrative Expenses	L... 14 000,00		560,0	2 500,00		2 500,00
8300	Computer Expenses	L...					
8310	Software	I...			1 000,00		1 000,00

1 7 31 3 12 | Account | Functions | Help

Basic business specification

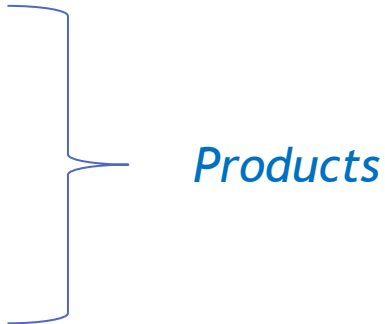
- * 100 000 Tones per Year
 - * *Carbonless papers*
 - * *Cast coated papers and Board*
 - * *Coated papers*
 - * *House brands*
 - * *Office papers*
 - * 5000 locations in HQ and 40 000 M² warehousing space
 - * 50000 customers
 - * 90 vehicles
 - * FEC trading (Forward Exchange Contracts)
 - * Hundreds of employees
 - * Heterogeneous IT system with **every day synchronization** of data in HQ and subsidiaries
 - * High volume-low margin type of business
- 
- Products*

Basic requirement

- * One database only (MS SQL)
- * Modern IT technology ensuring :
 - * Fast access to data providing on-line information any time
 - * Easy upgrades
 - * Mobile technologies (BAR code readers,..)
 - * Quick response to business partner requirements
 - * Multidimensional analytic tool->reporting to support decision making process
 - * Efficient warehousing (inbound and outbound operations)
 - * On-line reporting (warehouse status, accounting, cost control,.....)

* Isolated Data Islands

Accounting Island



Marketing

Marketing & Sales Islands



Production Island



Customer Orders



Sales Representatives



Customers Banks



Replenishment planning - Vendors

Island of Deliveries



Quality Management

Quality Management Island



Inventory - warehousing

One Solution ● One Database ● All Microsoft



Communications limits (band width, stable connection...)

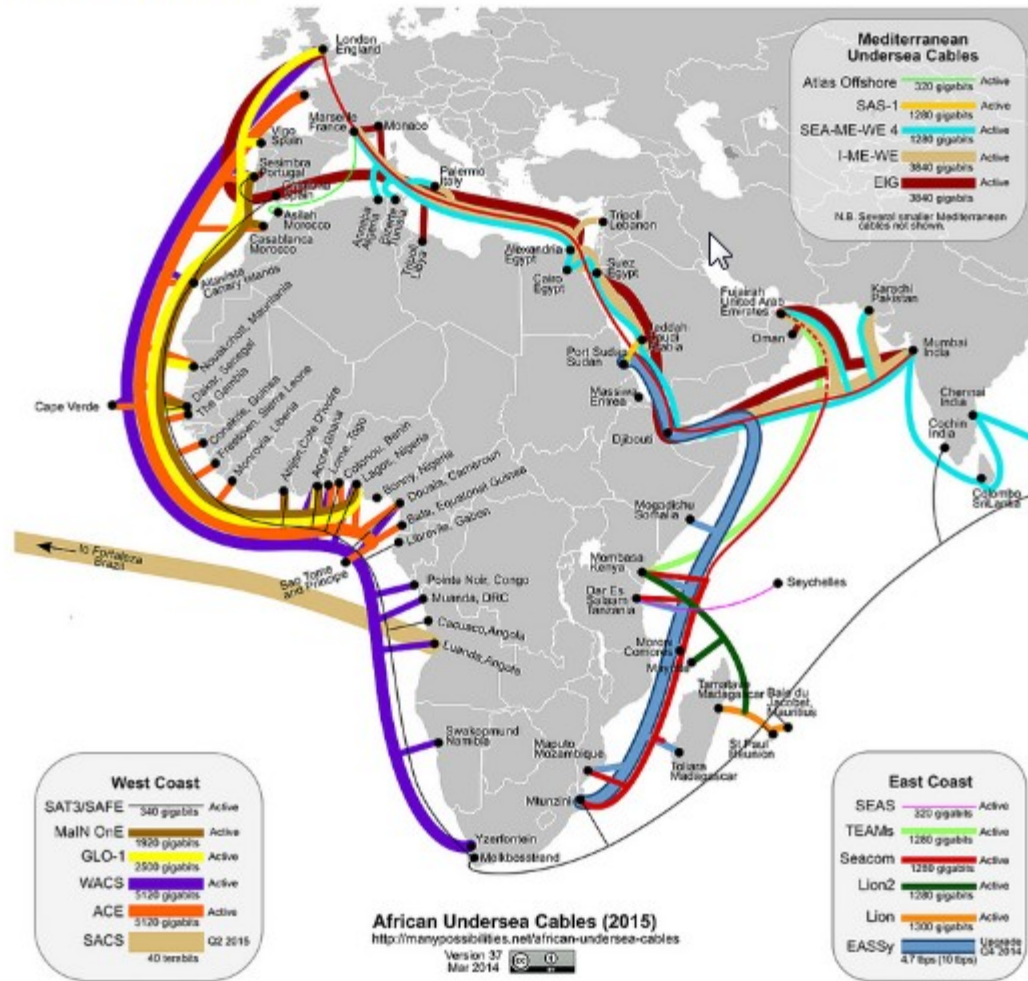

Efficient warehousing

-(only a few examples)

- * Receipt bins (area where lorries are unloaded)
- * Put-away to bins (racks) based on zones definition
- * Capacities of the bins (racks) - (weight, size)
- * Cross docking (from inbound area directly to outbound area)
- * Transfer between location (HQ and subsidiaries)
- * Picking slips (from rack to shipment area)
- * Shipments area (bins, cages)
- * Transport planning
- * Credit limits and overdue payment check
- * Invoices, Credit memos,....
- * Claim management

*Warehousing

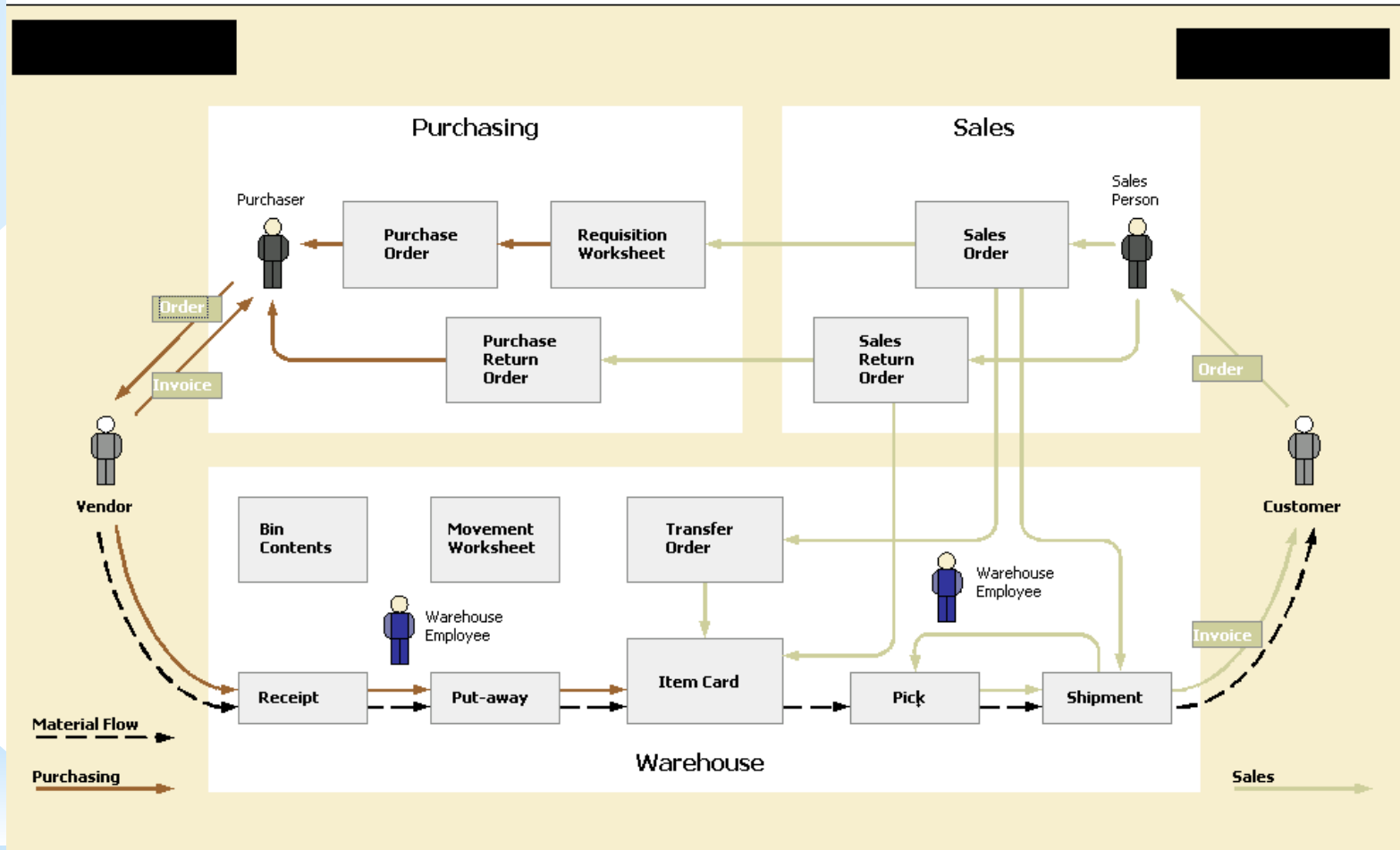

*Warehousing

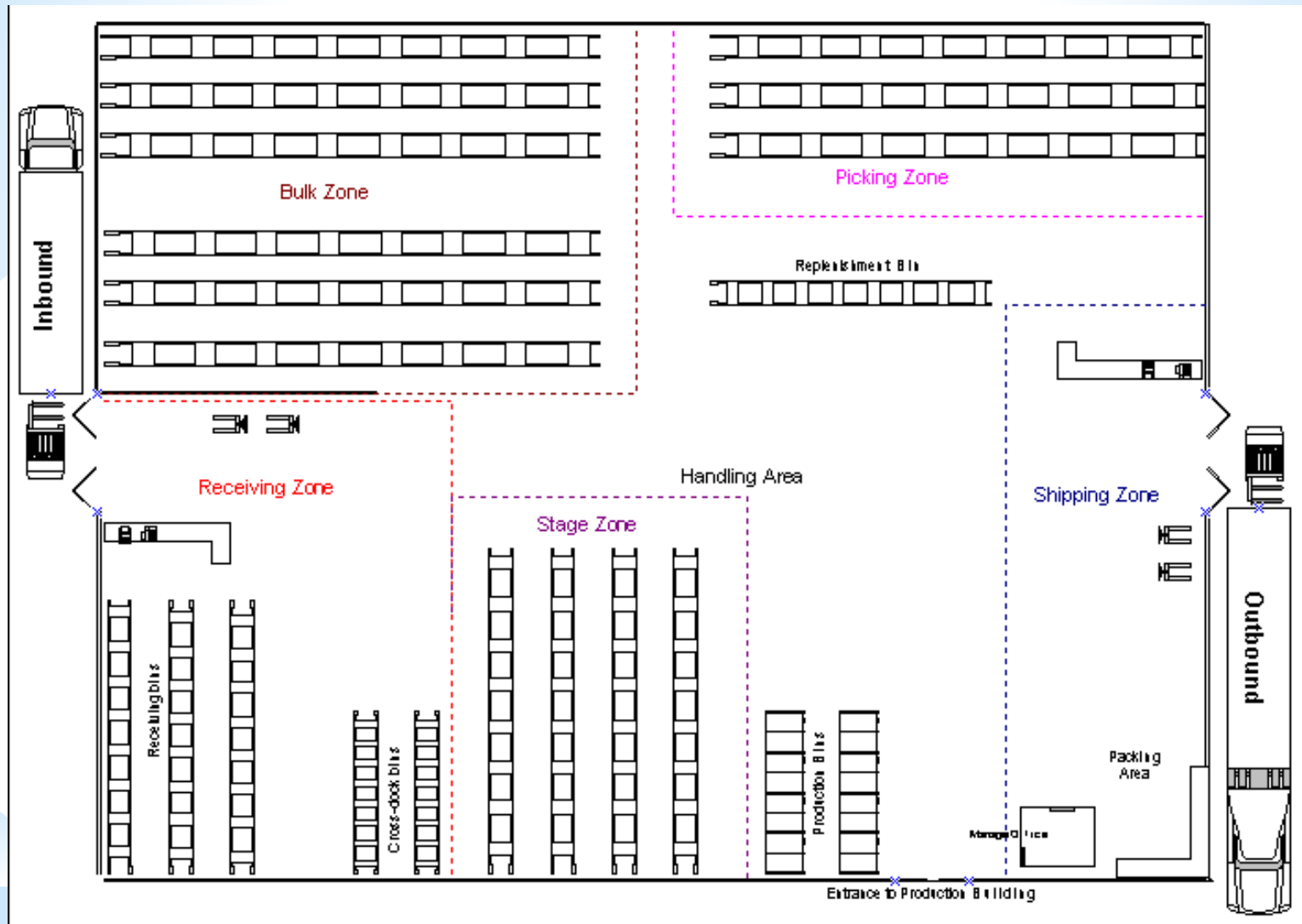



*Project management



Project Management

- * Budget <-> Quote and contract
- * Planning of resources and task control
- * Planning tools - see following slides
- * Reporting (time-capacity usage, costs,...)
- * Change management
- * Project Risks
- * Consignment stock
- * CPM, PERT, CCPM - will be mentioned later

* Resource Planner tool

The screenshot displays the CRONUS Combo Demo 2013 R2 Resource Planner tool interface. The main window is titled "CRONUS Combo Demo 2013 R2" and shows a navigation menu on the left with options like "Role Center", "Jobs", "Planning Jobs", "Quote Jobs", "Order Jobs", "Contacts", "Customers", "Vendors", "Items", "PlannerOne Resource Planner", "Earned Rev. Worksheet", "Requisition Worksheets", "Job Journals", "Job G/L Journals", "Recurring Job Journals", "Completed Jobs", "Job Registers", "Sales Quotes", and "Sales Orders".

The central dashboard, titled "Role Center - Job Manager", is divided into three main sections: "Jobs", "Sales", and "Purchases". Each section contains several data points represented by 3D bar charts:

- Jobs:** Planning Jobs (2), Quote Jobs (6), Order Jobs (50).
- Sales:** Sales Quotes (12), Sales Orders (64), Sales Invoices (4), Sales Cr. Memos (1).
- Purchases:** Purchase Quotes (3), Purchase Orders (27), Purchase Invoices (1), Purchase Credit Memos (0).

On the right side, there are several data visualization panels:

- My Job Estimate to Actual:** A bar chart showing estimates vs. actuals for Job Numbers 1006-01, 5010-01, and 5010-02.
- My Jobs:** A table listing jobs with columns for Job No., Description, Description 2, Start Date, and Status.
- Customers per Salesperson:** A bar chart showing customer counts for Salesperson Codes DC, JR, and PS.
- My Customers:** A table listing customers with columns for Customer ID, Phone No., and Name.

At the bottom, there is a "My Notifications" section with a table of alerts:

From	Created Date	Note	Page
CCSNET,RICK	3/28/2014	Check the Subcontract Expenses on this Job please.	Job Card - 1006...

*Resource Planner tool

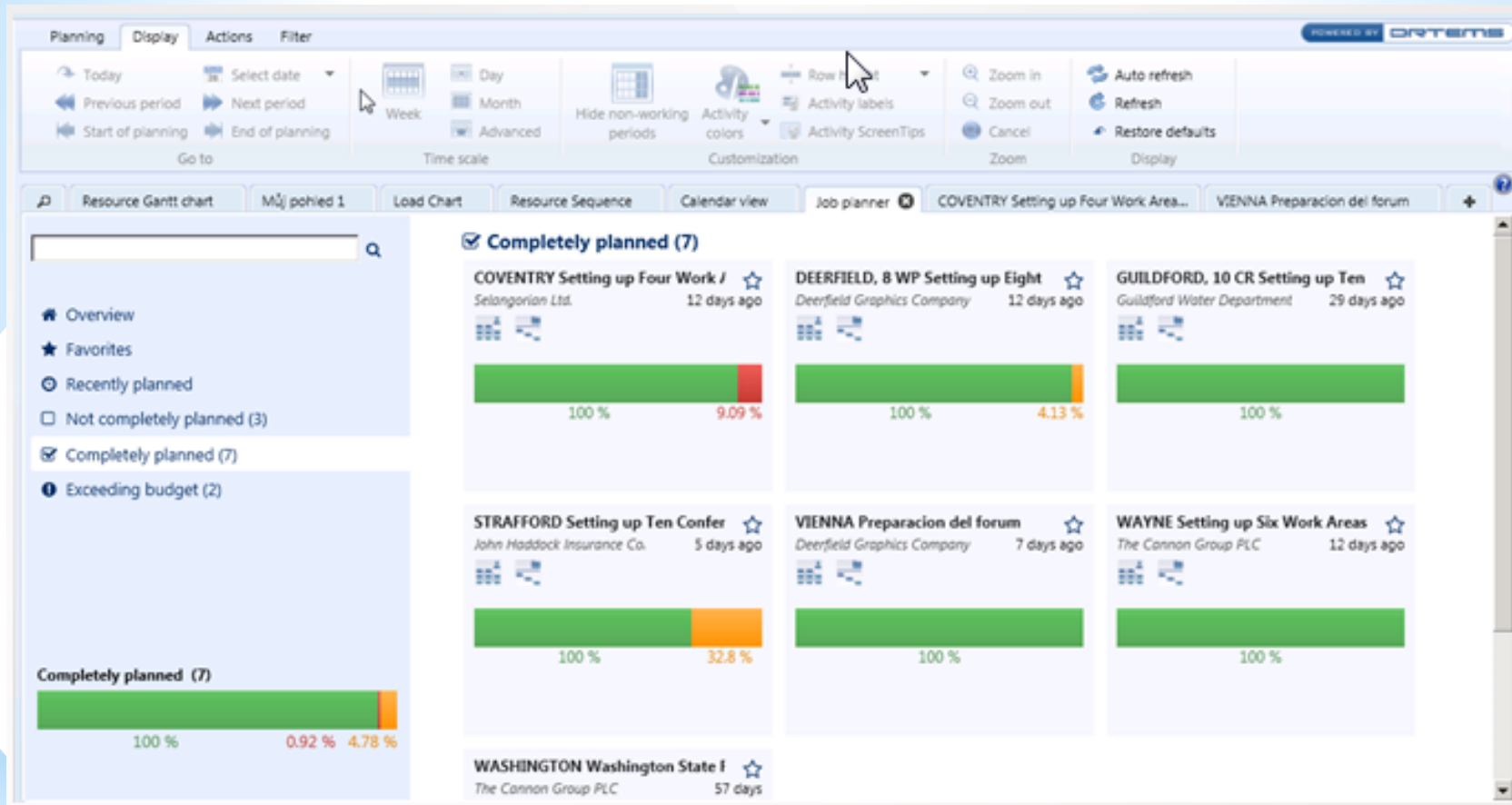

*Resource Planner tool

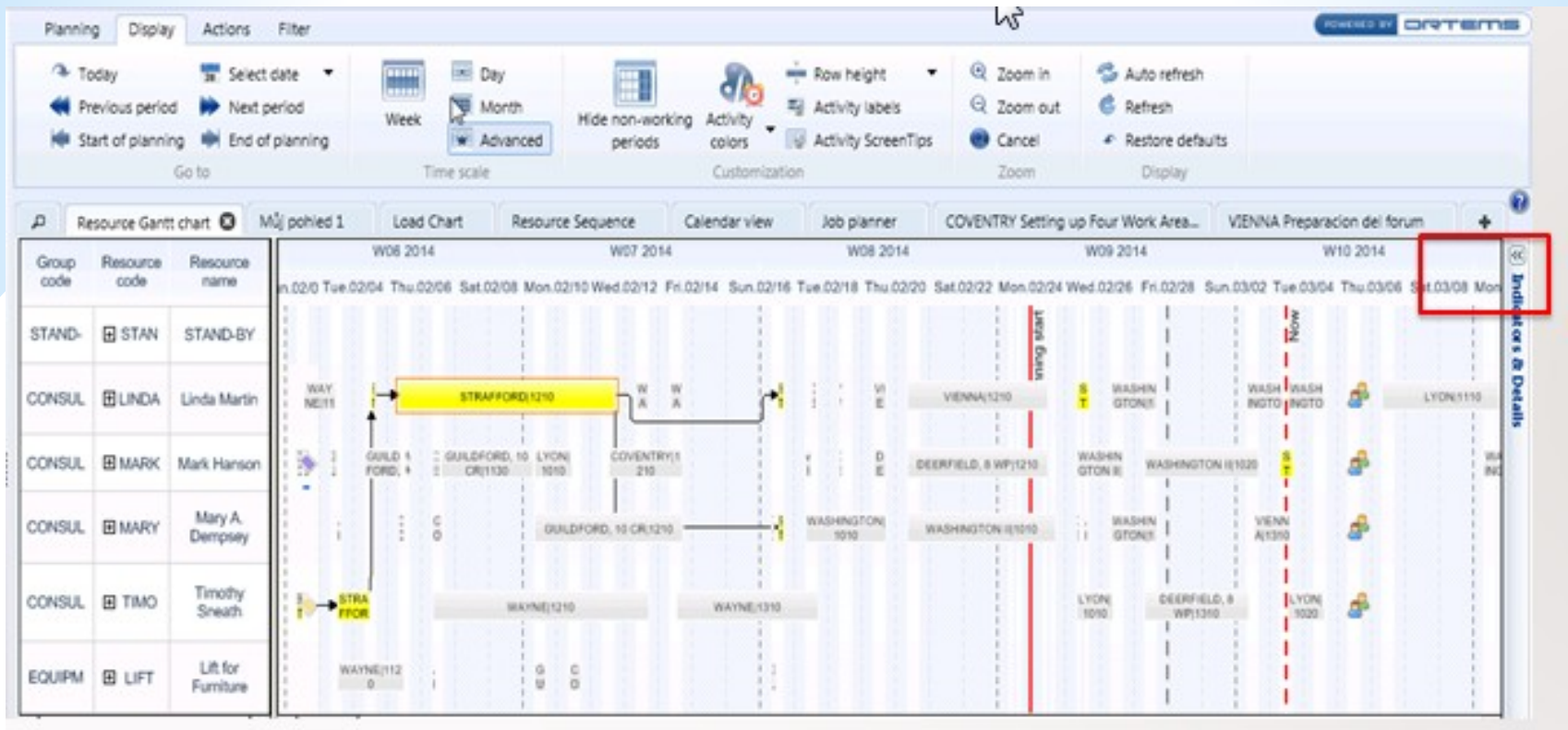

* Consignment stock (benefits)

 = palette

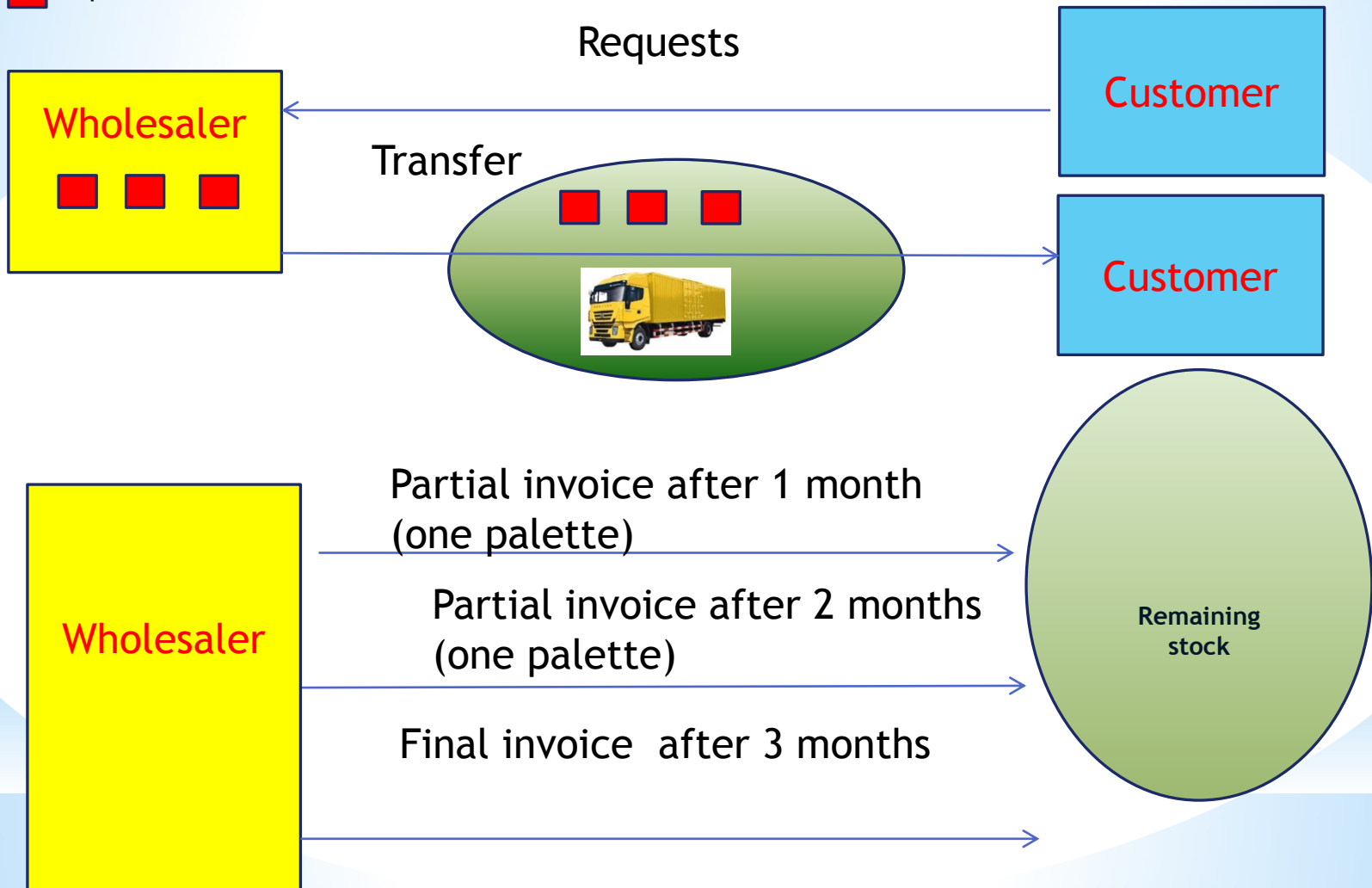

* Forward Exchange Contract (home study only)

A special type of foreign currency transaction. Forward contracts are agreements between two parties to exchange two designated currencies at a specific time in the future. These contracts always take place on a date after the date that the **spot** contract settles, and are used to protect the buyer from fluctuations in currency prices.

Opened from Purchase order (MS Dynamics NAV 2013)

Contract No.	Currency Code	Date	Exchange Rate	Spot Rate	Amount	Amount (LCY)	Used Amount	Amount to Invoice
FEC01	USD	22.7.2014	10,678	10,000	1 000,00	10 678,00	1 000,00	0,00
FEC03	USD	31.7.2014	10,700	10,000	400,00	4 280,00	400,00	0,00

*Staff training



Project Management

- * Study materials
- * Key users - roles, processes
- * Training :planning
- * Examination
- * Change management

*Project Management



Project Management

- * Budget (financial and resource capacities)
- * Data transfers (old system -> new system)
- * Setup of the ERP system (MS Dynamics NAV)
- * Tests
- * Evaluation of customized solution
- * Change management
- * Sharp start
- * Closing project - evaluation

*Implementation

- * Data transfer
- * Setup of the system
- * Role Tailored Clients- profiles, Approvals
- * Tests
- * Evaluation
- * Change management
- * Sharp start (Namibia and SA)
- * Closing project
- * Next stages



THIS IS

THE END