

# Towards the Universal View: Diamond Path Framework (Diamond of Attention, Diamond of Cognitive Elements)

PA116 – L8

(c) Zdenko Staníček, Sept 2010



INVESTMENTS IN EDUCATION DEVELOPMENT

# Topics

- Introductory comments
- MENTION – USE principle
- Diamond of attention – structure
- Diamond of attention – operations (behavior)
- Universality and Fixing-point
- Diamond of Cognition
- Duality of these Diamonds
- Diam2 explanation

# CMM

Permanent process  
improvement

**5. Optimized**  
- capability of continual  
process improvement

Measurable goals in terms of  
process and product quality

**4. Managed**  
- metrics for process and  
products quality measurement

Defining of enter-  
prise processes

**3. Defined**  
- base for process monitoring  
- comparing of projects

Basic  
standards

**2. Repeatable**  
- descriptions exists  
- experience from the past

**1. Accidental**  
- ad hoc, non-formal

What is our  
today position  
???

# What kind of IS is required by specific CMM Level?

- Level 2 = classic IS
- Level 3 = Level 2 + business process modeling in four BPM dimensions  
>> to allow to mention models
- Level 4 = Level 3 + simulations and workflow, systems monitoring events in classic IS  
>> to allow to use models
- Level 5 = Is there any IS like this today?  
>> ???

# The Unity of Modeled and Modeling World principle

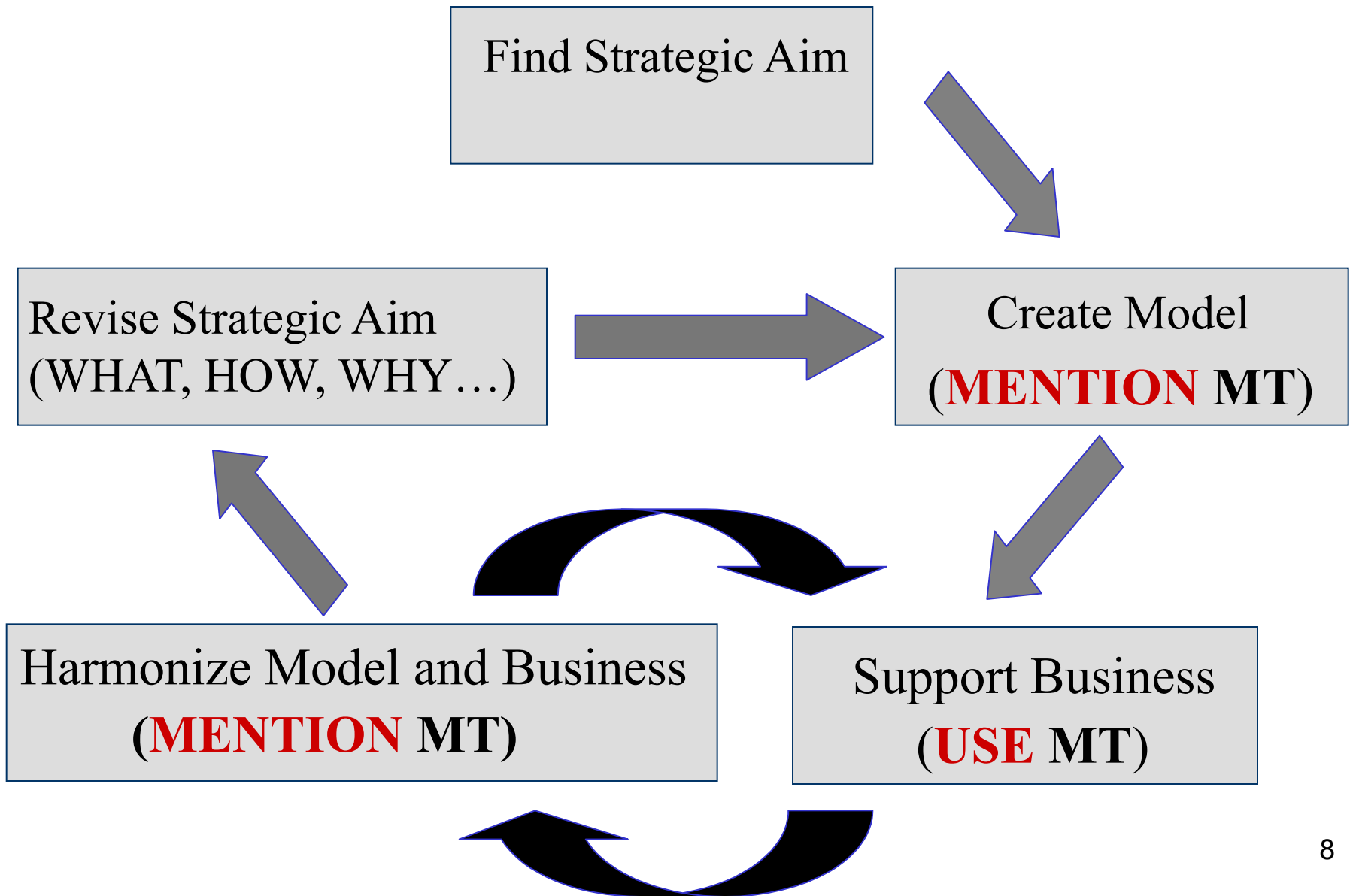
- *ICT tools and system of their deployment in a company/organization must be realized in such a way, that **they are able to model** present and intended processes in particular contexts, as well as **support** operativeness of these processes execution, **in one uniform environment.***
- Otherwise it is not possible to reach CMM Level 5.

# Work with the „unknown“ principle

- Careful examination of CMM Level 5 reveals that it is necessary to formulate another one „very daring“ principle:
- *SW supporting business has to be designed in a way, that it is able to support even those requirements, that we are not today aware of.*

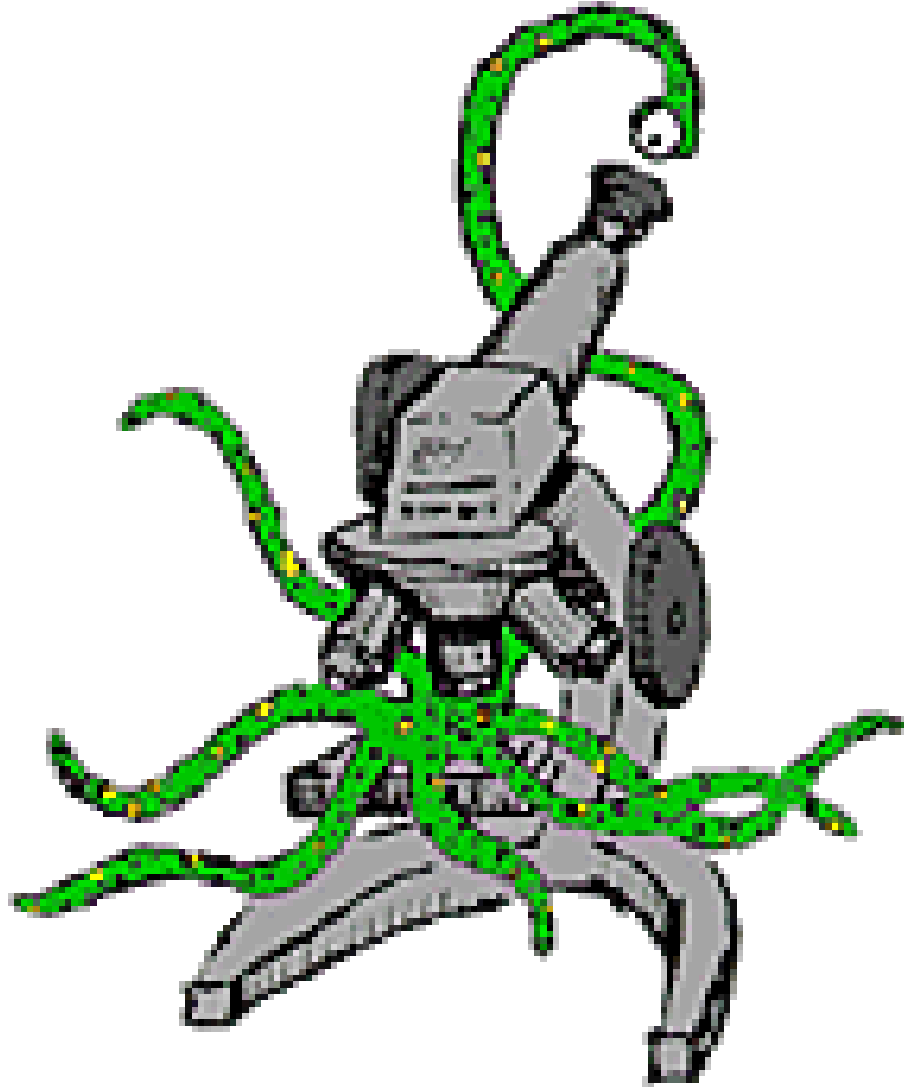
How to solve it ?  
- the Unity principle  
- the Unknown principle

# Review: Cyclical paradigm





# Self-reference !



... we need a magic wand ! ?

Two operations could be  
helpful:

**MENTION**  
and  
**USE**

# MENTION operation

- MENTION operation applied on an object, that we have focused our attention on, allows us to **directly** „speak about“, „describe“ and „elaborate on“ anything that we commonly use, e.g. to model/simulate business processes. MENTION has to enable development and update of anything, that (in *use mode*) supports knowledge acquisition and manipulation. MENTION has to provide possibility to continually develop knowledge about ‘what knowledge we need’ and ‘how to manipulate it’.
- **MENTION operation returns focused object in *mention mode***

# USE operation

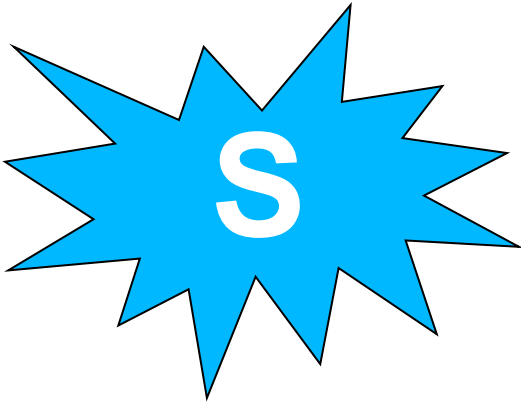
- USE operation applied to an object, that we have focused our attention on, allows us to **directly** use anything that we have designed in *mention mode*. It has to provide possibility to carry out what the object is for.
- USE operation returns focused object in *use mode*

# Infinite sequence of metamodels?

- When creating a model, we mention its elements (objects) and its structure. When using a model, we work with it as with a modeling tool.
- In order to create a model, we often ascend to metamodel (modeling tool) level, which allows us to create the model.  
In order to use a model, we descend to the original level and use the model itself as a modeling tool.
- The problem is in switching between model and metamodel level.
- This produces potentially infinite sequence of metamodels, provided we do not have MENTION and USE operations.

# MENTION – USE principle or Universality principle

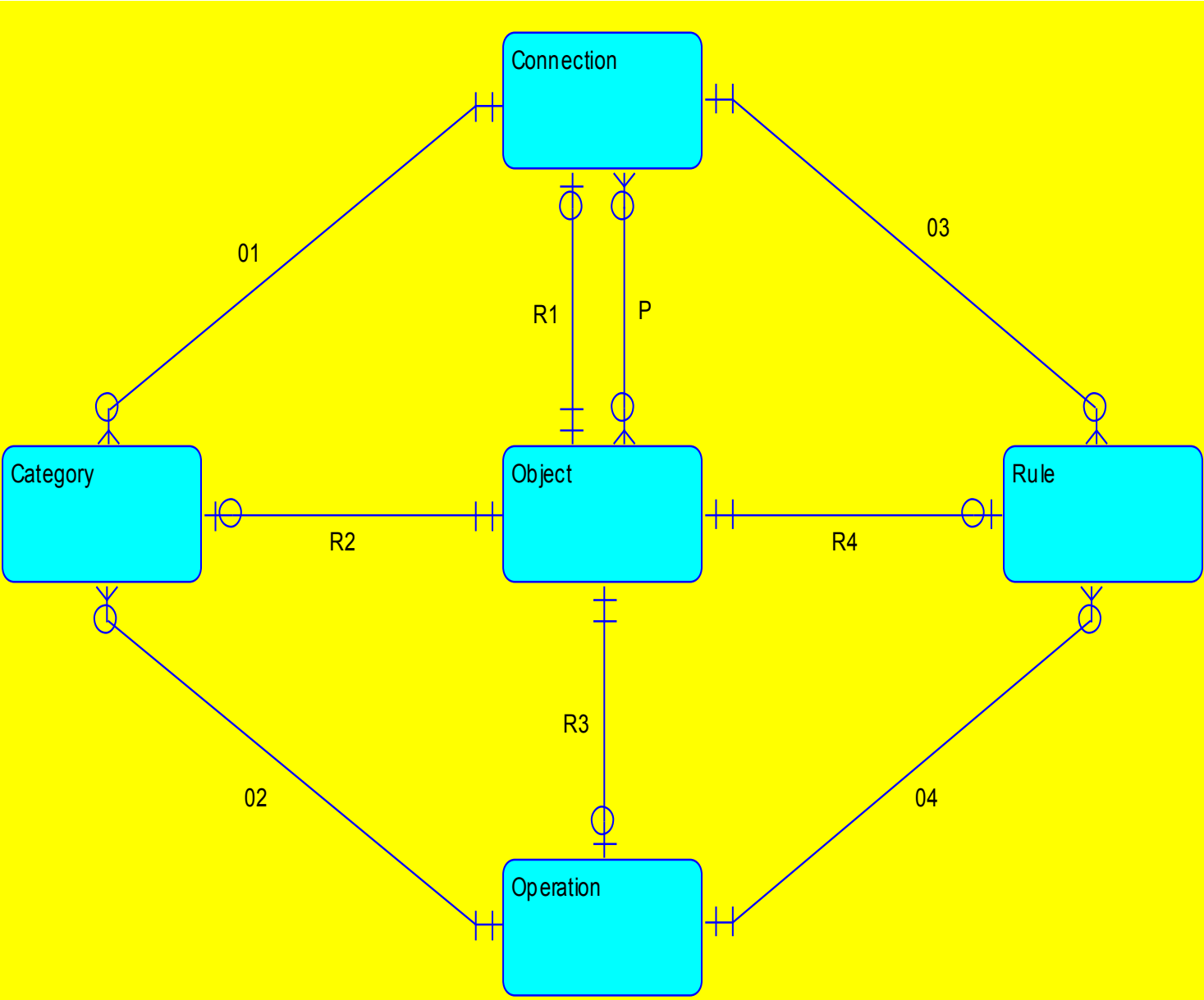
- *Modeling Tool MT is a universal one if:*
  - (1) *it has capability to model any model (in accordance with modeling tool definition)*
  - (2) *let  $MT = (CAT, CNN, OPE, RUL)$ , then there exist MENTION and USE operations in OPE, which have previously stated properties.*



# Diamond of Attention Focusing (Diam1)

In accordance with “enactive  
perception” principle:  
a way how “to **see**” effectively





# Container ( $\neq$ type)

- **Agreement:** *Any ideational construct that can be used for arrangement of some elements*, where an element can be anything on which we can focus, will be **called a *container***. *Even an implementation of such a construct in ICT will be considered to be a container.*
- Container may be empty or may contain finite or infinite number of elements.
- **Elements can be inserted into the container as well as *removed from it*.**
- When an element is a member of a container, we say the element *dwells* in the container or it is *stored* in the container.

# Examples

- Containers are classes of objects, categories, type or kind entities in a database, files, whole databases etc.
- In general, every MT is a container. It is a container for models.
- MT is a container composed of other containers, that are used for storing individual instances according to particular properties. We create models from these instances.



CYBERSPACE

# DMT-object

- Every element stored in DMT, that depicts an object (entity) of reality we are getting to know and are able to focus our attention on, will be called *dmt-object*. We say, that - for modeling purposes - *dmt-object represents* object of modeled reality.
- Object of modeled reality, that we focus attention on, will be called *focused object*. We speak about focused (represented) object properties as about its representing object properties.



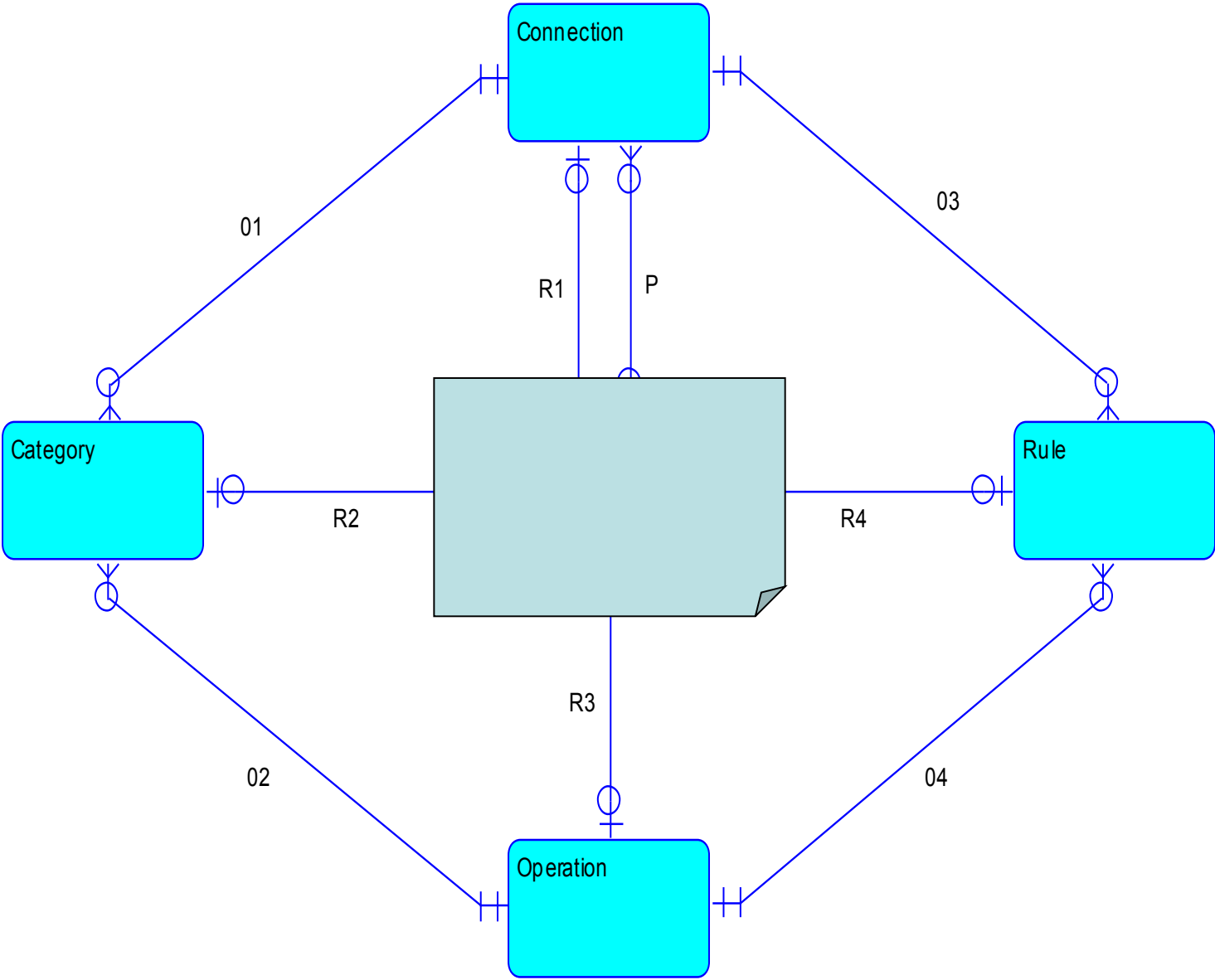
CYBERSPACE



PHYSICAL WORLD

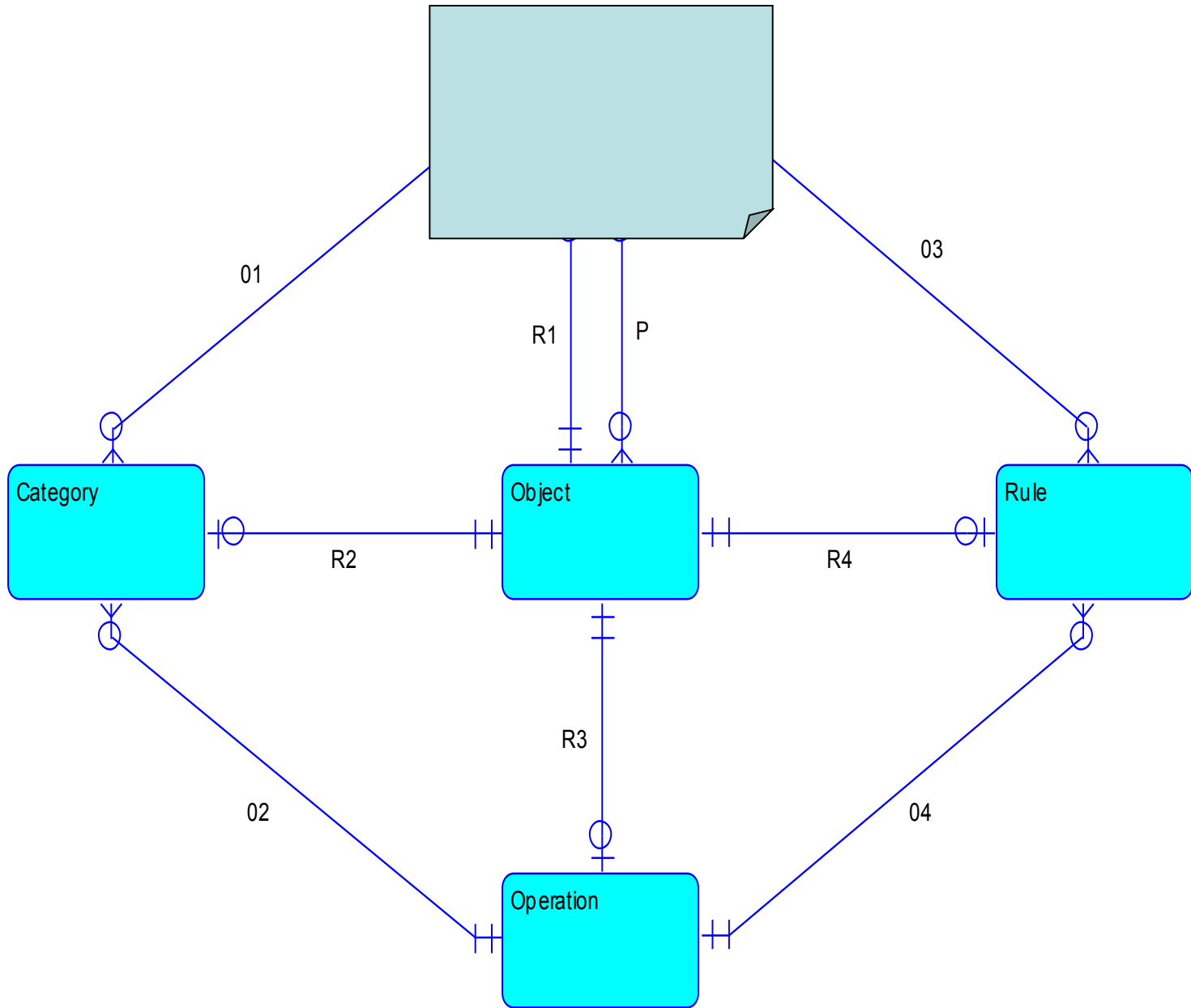
# Container (#Object)

- Dmt-objects dwell in container (#Object) in Diamond. Containers used in Diamond will be defined by specification of their member elements.
- Container (#Object) is defined in such a way that it contains all such dmt-objects which can be mentioned in DMT, i.e. which ***can be assigned certain properties.***



# Container (#Connection)

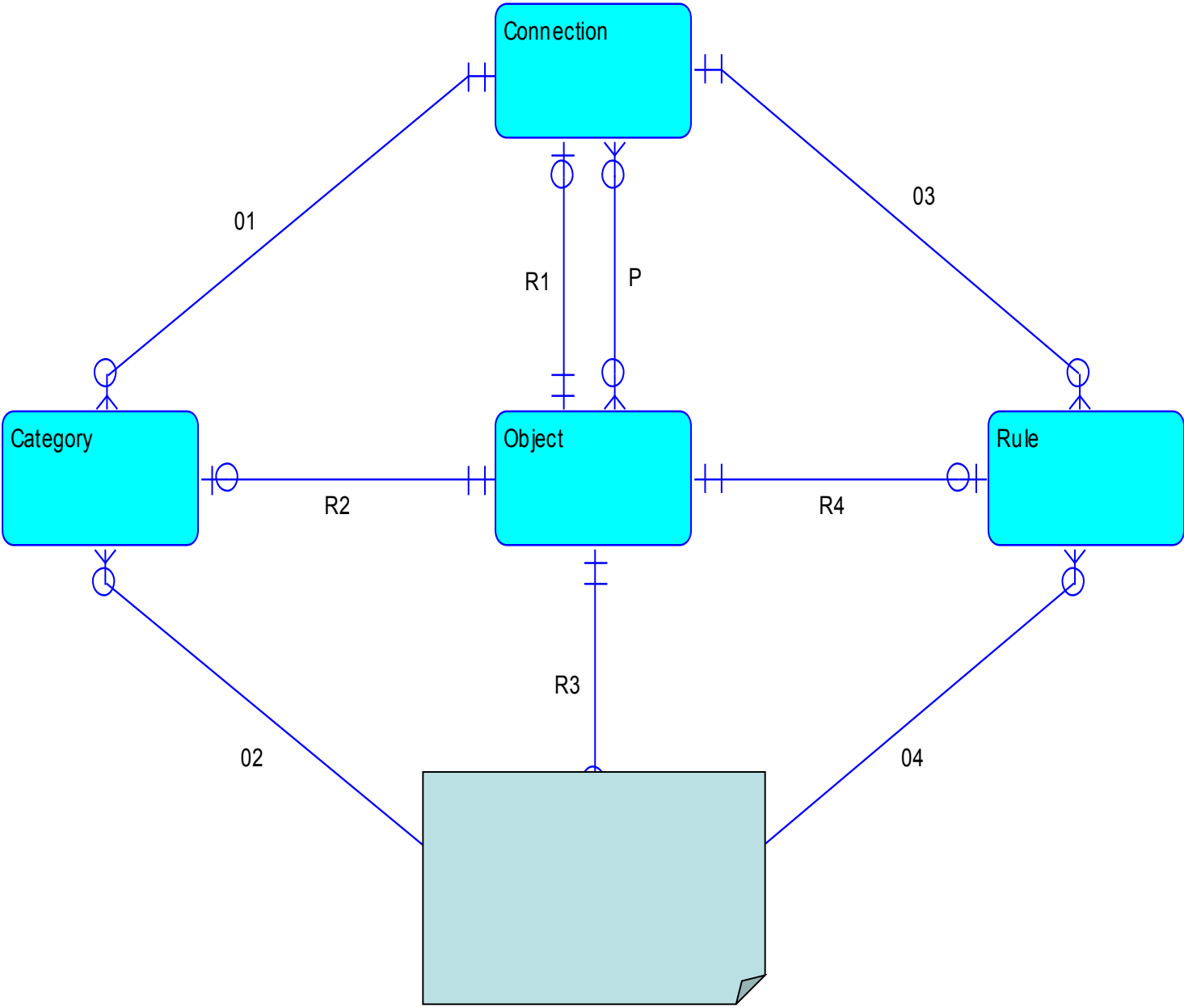
- Container (#Connection) is defined in such a way that every of its elements is a sequence of the length  $n$  ( $n$ -tuple) of dmt-objects, where  $n$  is some finite natural number.
- Every element of the container (#Connection) is called a **connection** or a **sequence**.
- Container (#Connection) contains by definition one special element  $\perp$  called improper connection. It is not possible to determine objects constituting improper connection.





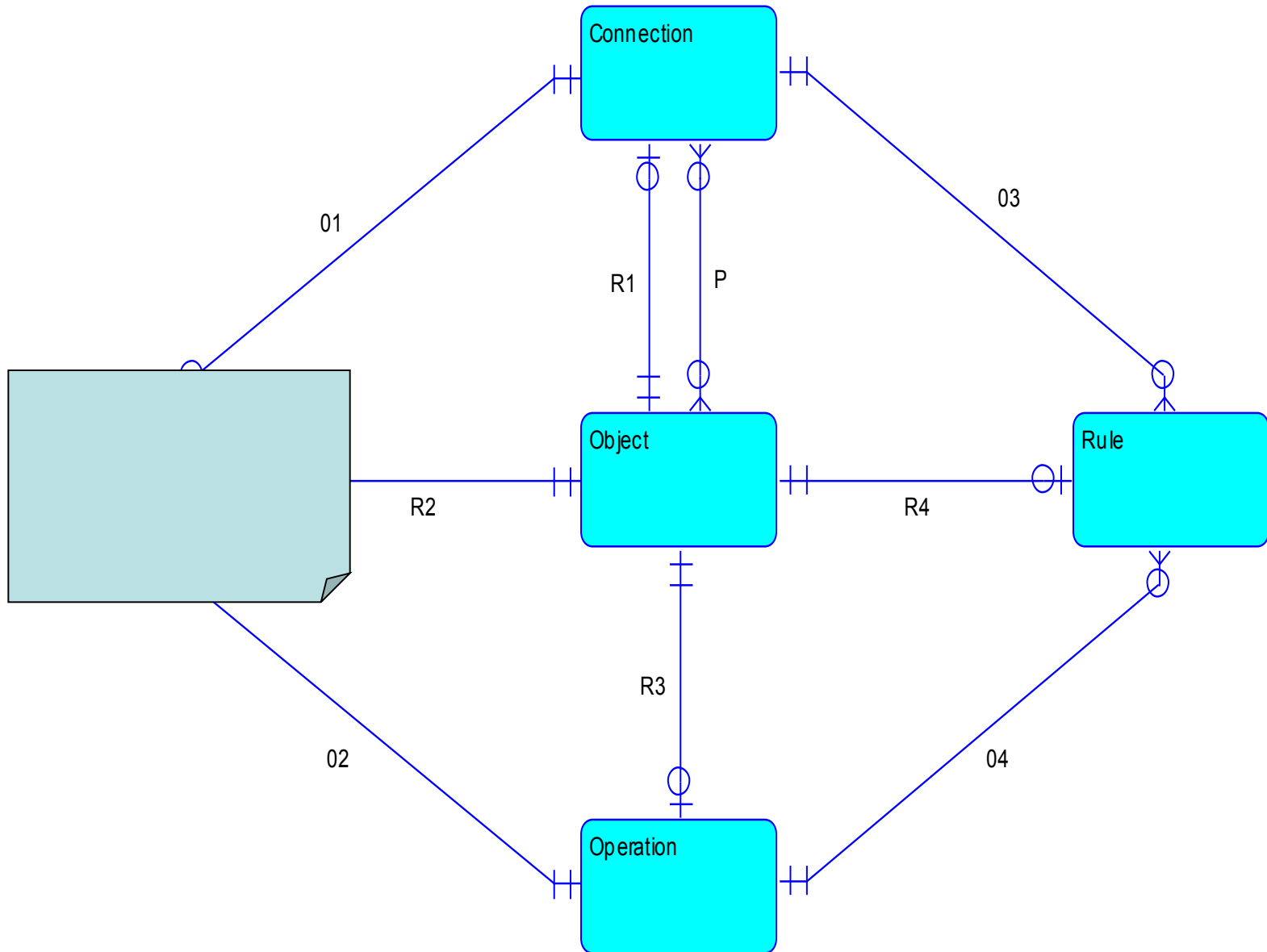
# Container (#Operation)

- Container (#Operation) is defined in such a way that every of its elements is an algorithmically computable transformation of one state of DMT to, generally, another state of DMT.
- By the state of DMT we mean one particular filling of DMT (as a container) by elements-instances, that may dwell in DMT.
- We assume there always are two (boolean) objects in DMT, one of them codes True, the other False.
- The elements of the container (#Operation) are called ***operations***.
- Some operations may *fail*, i.e. return object coding False, under certain circumstances and *succeed under different circumstances*. Some operations always succeed.



# Container (#Category)

- Container (#Category) is defined in such a way that every of its elements has the following properties:
  1. it is a container for dmt-objects,
  2. it is one-to-one mapped to the pair  $\langle C_n, O_p \rangle$ , where  $C_n \in (\#Connection)$ ,  $O_p \in (\#Operation)$ , and
  3. it holds about the operation  $O_p$  that by means of the connection  $C_n$  it can recognize whether a given object is or is not in this container.
- The elements of the container (#Category) are called **categories**.
- The connection  $C_n$  is called a *defining connection* of this category, the operation  $O_p$  is called a *defining operation* or an *evaluator* of this category.



# Observation 1

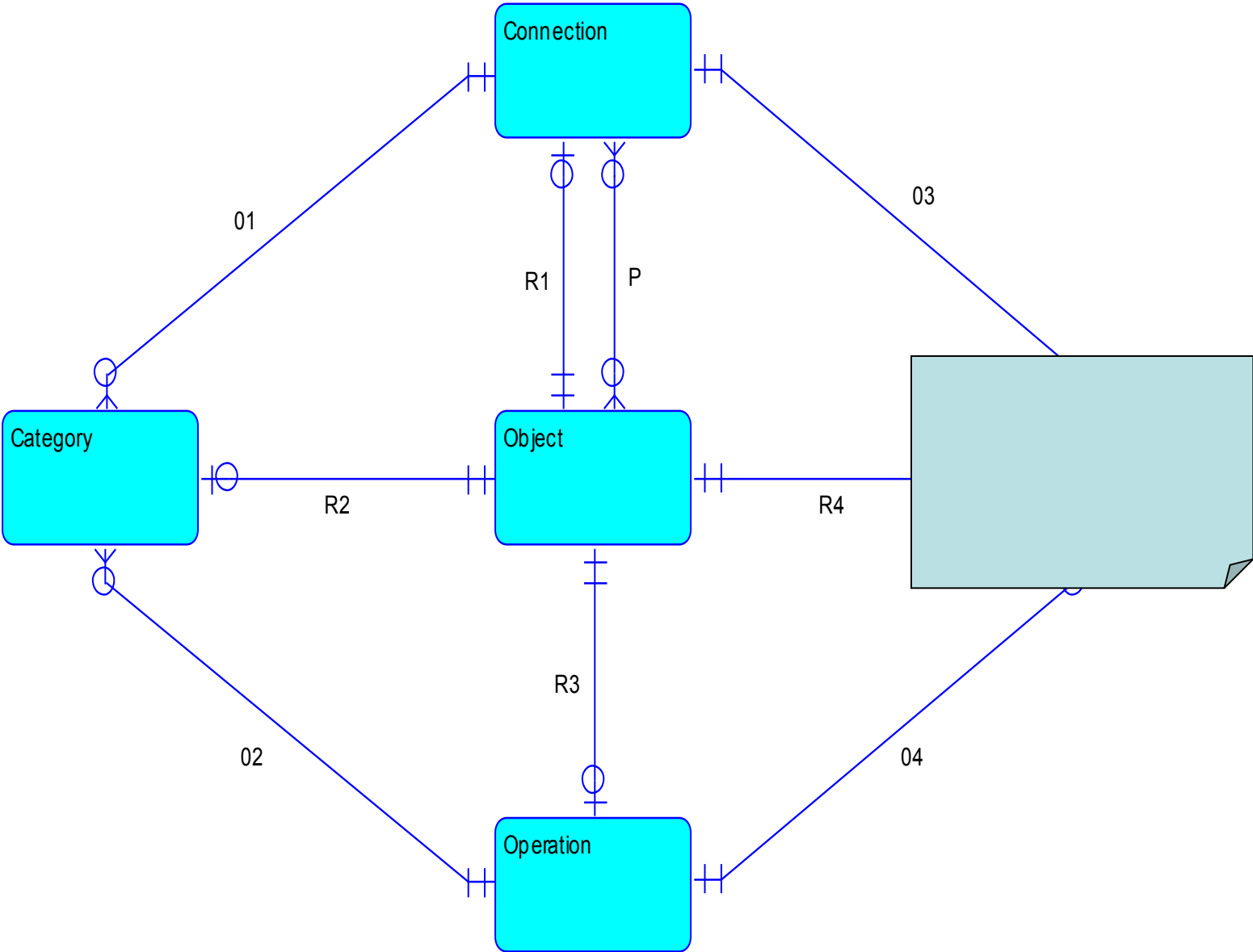
- Category definition allows connection  $C_n$  to be in some cases improper (i.e.  $C_n = \perp$ , which means, that list of connected objects is empty in all states of world). Then the determination of category members is based on evaluator application only.
- On the contrary, evaluator must not be improper under any circumstances. Otherwise it would be impossible to determine which objects are members of the category.

# Observation 2

- Fundamental fact about this definition of category is, that categories are not some primitive elements created outside the scope of using DMT, but **we have the categories creation and categorization process at our disposal directly in DMT.**
- This fact makes DMT considerably different from most of other tools, that treat categories as already complete things. Such tools do not deal with categories creation, they allow only to manipulate them.

# Container (#Rule)

- Container (#Rule) is defined in such a way that every of its elements has the following properties:
  1. it is a dmt-object,
  2. it is one-to-one mapped to the pair  $\langle Cn, Op \rangle$ , where  $Cn \in (\#Connection)$ ,  $Op \in (\#Operation)$ , and
  3. operation  $Op$ , by means of the connection  $Cn$ , carries out a test whether the rule is valid, i.e. the operation returns the value `True` if the test is *successful*, and value `False` in the *opposite case*.
- The elements of the container (#Rule) are called **rules**.
- The connection  $Cn$  is called a *specifying connection* of this rule. The operation  $Op$  is called a *specifying (or testing) operation* of this rule.





# Observation

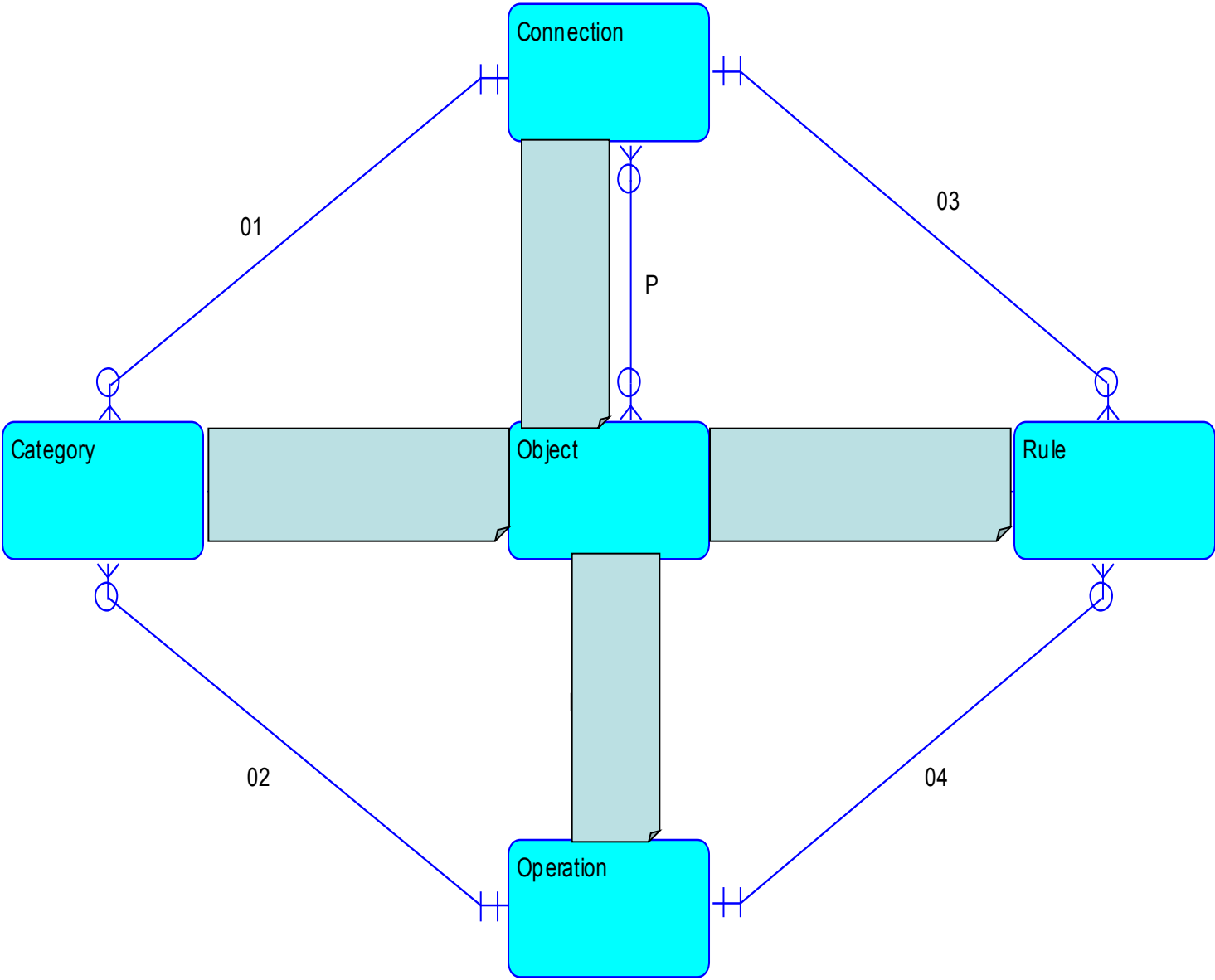
- Rule definition allows again connection  $C_n$  to be improper ( $\perp$ ) in some cases. Then the determination of rule satisfaction is based only on specifying operation application. However, specifying operation must not be improper under any circumstances. Otherwise it would be impossible to carry out test defined by the rule.

# Diamond semantics

- **Objects established by preceding definitions form the semantics of DMT modeling language. Universal modeling does not require anything more.**
- *Every connection, operation, category and rule is contained in container (#Object).*

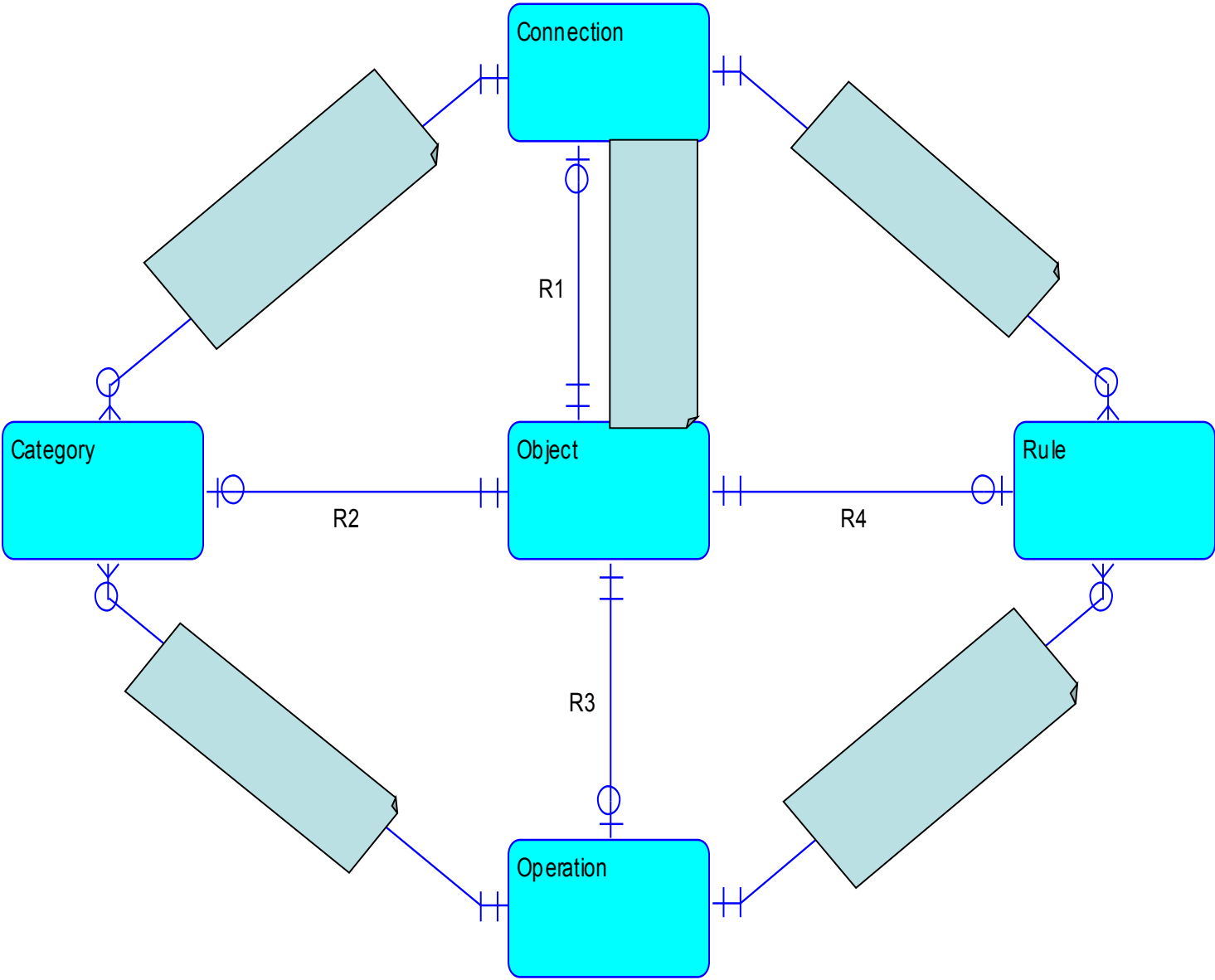
# Universality Principle Implementation

- Edges R1, R2, R3 and R4 are together called R-edges. R-edges serve to perform transitions between **mentioning** and **using** and vice-versa.
- If we focus on a concrete object of the class #Object, which was spoken of in a way (MENTION), then by the operation **USE** we will pass the relevant R-edge and we will reach represented sequence (#Connection) or operation (#Operation) or category (#Category) or rule (#Rule), which could be then directly used, or we will reach nothing.
- If we focus any vertex of the Diamond graph on the other hand (which we used in a way - USE), then by the operation **MENTION** we will pass the relevant R-edge and we will reach this vertex representing object, which we can speak of directly.



# Perimeter edges and p-edge

- Edges 01 and 02 from the figure connect category to this category *defining connection* and *defining operation*, respectively.
- Edges 03 and 04 connect rule to this rule *specifying connection* and *testing operation*, respectively.
- ‘Specifying connection’ of a rule can be an object representing the whole model described by this (or related to) the rule.
- Last, p-edge (projection) connects connection (sequence) to this sequence creating particular object.



# Basic Operations Outline

- Operations of creation, deletion, actualization, access and detection of dmt-objects
  - Create, Delete
  - Write, Read
  - Obtain
  - Label (detection what an object is about)
- Operations of „travelling“ on the Diamond perimeter
  - Get (Con, Ope, Cat, Rul)
- Operations with p-edge

# Operation MENTION

- If the operation is applied to the centre of the Diamond, i.e. to an instance of dmt-entity (#Object), it will return this object.
- If the operation is applied to any vertex of the Diamond, it will pass relevant R-edge and will return object, which represents this Diamond vertex (just for the purpose of mentioning).
- This operation never fails. That is to say 'mentioned can be anything'.



# Operation USE

- **use\_obj(+*ldobj*)**  
Returns instance of this vertex of the Diamond, which is represented by this given object, i.e. it pass from the Diamond centre to the relevant vertex. Operation fails, if the given object represents nothing.
- **use\_con(+*ldcon*)**  
Returns a list of objects forming the given connection
- **use\_ope(+*ldope*,+*Arglist*)**  
Executes given operation (*ldope*) and as arguments it submits the content of the list (*Arglist*).

# Operation USE - continued

- **use\_cat(+*Idcat*,+*Arglist*)**  
Executes operation which is connected to the given category by the edge 02. This operation obtains as arguments the category (*Idcat*), the connection connected to this category by the edge 01 and arguments from the list *Arglist*.
- **use\_rul(+*Idrul*,+*Arglist*)**  
Executes operation which is connected to the given rule by the edge 04. This operation obtains as arguments the rule (*Idrul*), the connection connected to this rule by the edge 03 and arguments from the list *Arglist*.

# Universality Statement

- *Let  $DMT = (OBJ^D, CAT^D, CNN^D, OPE^D, RUL^D)$ , where  $OBJ^D$ ,  $CAT^D$ ,  $CNN^D$ ,  $OPE^D$  and  $RUL^D$  is defined as described above.*
- *Let  $MT = (CAT, CNN, OPE, RUL)$  is arbitrary modeling tool.*
- *Then  $MT \angle_{mc} DMT$ .*
- As DMT contains operations MENTION and USE, this is enough for its universality according to the MENTION – USE principle.
- Note:  $CNN^D$  is container for finite sequences;  $CNN$  is container for connection categories.

# MENTION – USE principle or Universality Principle (reminder)

- *Modeling Tool MT is a universal one if:*
  - (1) *it has capability to model any model (in accordance with modeling tool definition)*
  - (2) *let  $MT = (CAT, CNN, OPE, RUL)$ , then there exist MENTION and USE operations in OPE, which have previously stated properties.*

# Univ. Statement: principle of the proof - 1

- The proof is done in accordance with MT definition and the definition of 'model constructed by MT'.
- First, let's assume that MT can be constructed by DMT. Then, if M is arbitrary model constructed by MT, it could be constructed by DMT, owing to operation USE: anyway M is constructed from elements of categories from  $CAT \cup CNN$  with help of operations from OPE. But the above assumption yields: each category from  $CAT \cup CNN$  (and each element of this category) could be constructed by DMT. As well each operation from OPE could be expressed using DMT (there is a complete programming language at our disposal). Applying relevant operation USE to this way constructed categories from  $CAT \cup CNN$  and operations from OPE we construct the model M by using DMT.
- Hence, it is enough to prove that really MT could be constructed by DMT. The proof is a constructive one:

# Univ. Statement: principle of the proof - 2

- We insert an instance into the container (#Category) in DMT for each category from  $CAT \cup CNN$  of MT by means of relevant operation CREATE (**create\_cat**). Each fact that a category from CAT is bound in a particular connection from CNN of MT, we express in DMT by inserting one separate instance of (#Connection) (using the operation **create\_con**).
- Each operation from OPE of MT we insert into DMT as an instance of (#Operation) (by means of operation **create\_ope**).
- Each rule from RUL of MT we insert into DMT as an instance of (#Rule) (by means of operation **create\_rul**).
- All such inserted operations and rules could be executed owing to the operation USE.
- The categories, created in DMT according to patterns from  $CAT \cup CNN$ , could be filled up by their respective instances owing to operation USE, again. Using the special connections inserted by means of the operation **create\_con** we can simulate in DMT “the game” originally played in MT.
- Thus MT is a model constructed by DMT in accordance with the definition.

# COROLLARY:

- *Diamond (DMT), as it is a working modeling tool, can be, as a whole, constructed by the Diamond (DMT).*
- To construct the Diamond by the Diamond is not an autotelic plaything.
- If we want really, and without exceptions, to mention anything what we use somewhere, it is necessary to be able to mention Diamond elements themselves, as we use them to model something.
- This means: **self-reference is a consequence of universality**

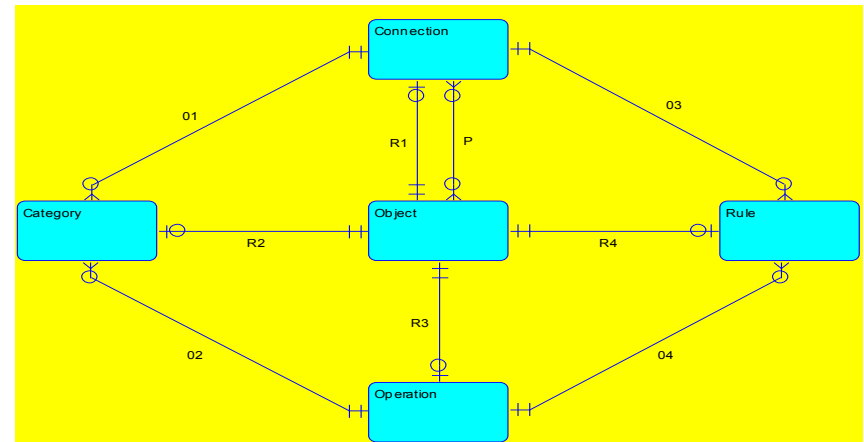
# How to start to work with universal modeling tool

- One day we need to start to work with a new created modeling tool.
- But, for this purpose the tool has to be prepared for using.
- If DMT is empty, it will be, evidently impossible to start in MENTION mode, i.e. to mention its elements, e.g.. There is nothing to mention at all in this case.
- Thus, the work with Diamond can start in USE mode, only.
- And not to have problems in the future (problems of a kind that something is not possible to execute) it is expedient “to anchor” the tool along with its first using.
- This “anchoring” could be done right by the construction of Diamond by this Diamond itself.



# The Primitive Fixing-point

- To create the *Primitive fixing-point* means:
  - Containers (#Object), (#Connection), (#Operation), (#Category) and (#Rule) of the Diamond are constructed by the Diamond
  - Container (#Operation) is filled up by basic operations (see figure in the right column) and by operations MENTION and USE



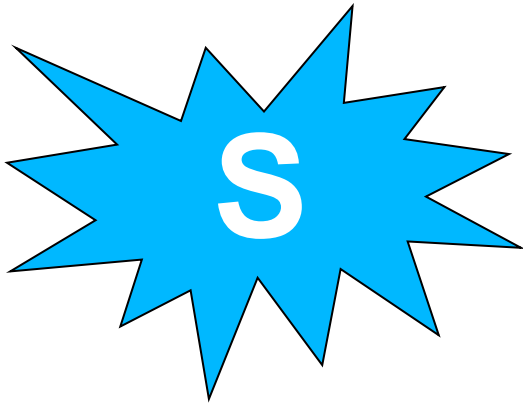
- Operations of creation, deletion, ...
  - Create, Delete
  - Write, Read
  - Obtain
  - Label (detection what an object is about)
- Operations of „travelling“ on the Diamond perimeter
  - Get (Con, Ope, Cat, Rul)
- Operations with p-edge

# Pragmatic approach

- Often we start to work with Diamond in a situation in which we want to understand a selected domain and to model it for the purpose to develop some Service System which will be able to operate.
- Such a domain could be: a business domain, scientific domain, a domain of learning of something, etc.
- It is necessary to take to account that such particular domains will be integrated somewhere in the future (this is the current state of world).
- Thus, it is better to prepare play-ground (often used and general categories and connections, often used and general operations and rules) along with the starting event with the Diamond, instead of the pure Primitive fixing-point.
- Hence, the starting construction of Diamond's elements by the Diamond is straight extended to the construction of the appropriate "play-ground" enabling information and knowledge synthesis.

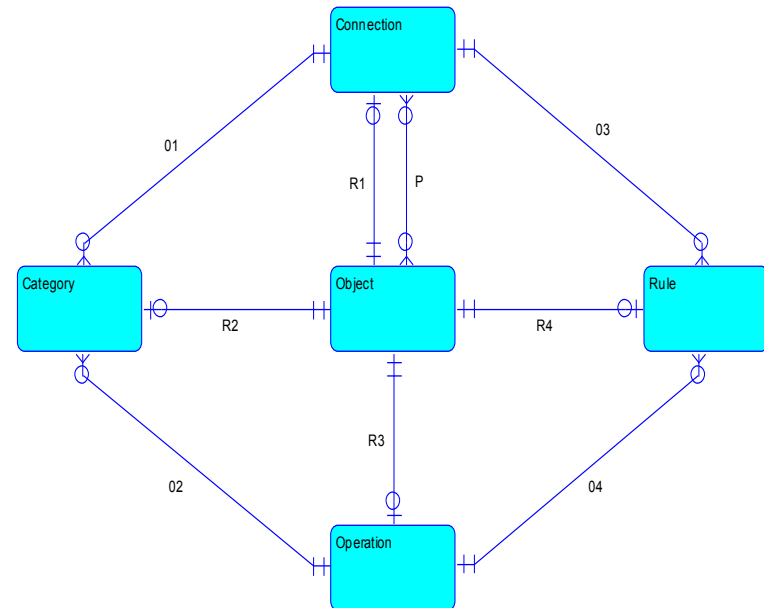
# Fixing-point

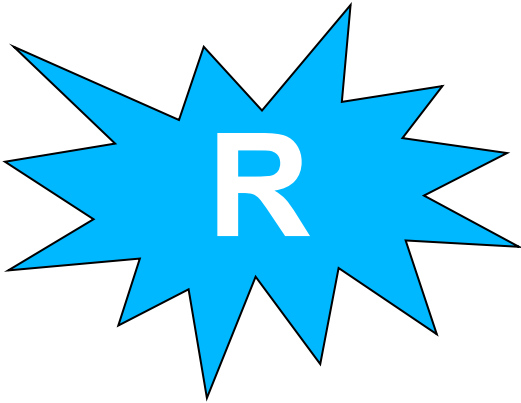
- By the term *Fixing-point* we denote the very first construction of all instances of dmt-entities which will be useful in course of working with Diamond, i.e., which will be used or mentioned in some super-domain of the domain under discussion.
- **Fixing-point is a pragmatic extension of the Primitive fixing-point.**



This was the way how “to **see**”  
effectively in any domain using  
Universal Modeling Principle

# Diamond of Attention Focusing (Diam1)



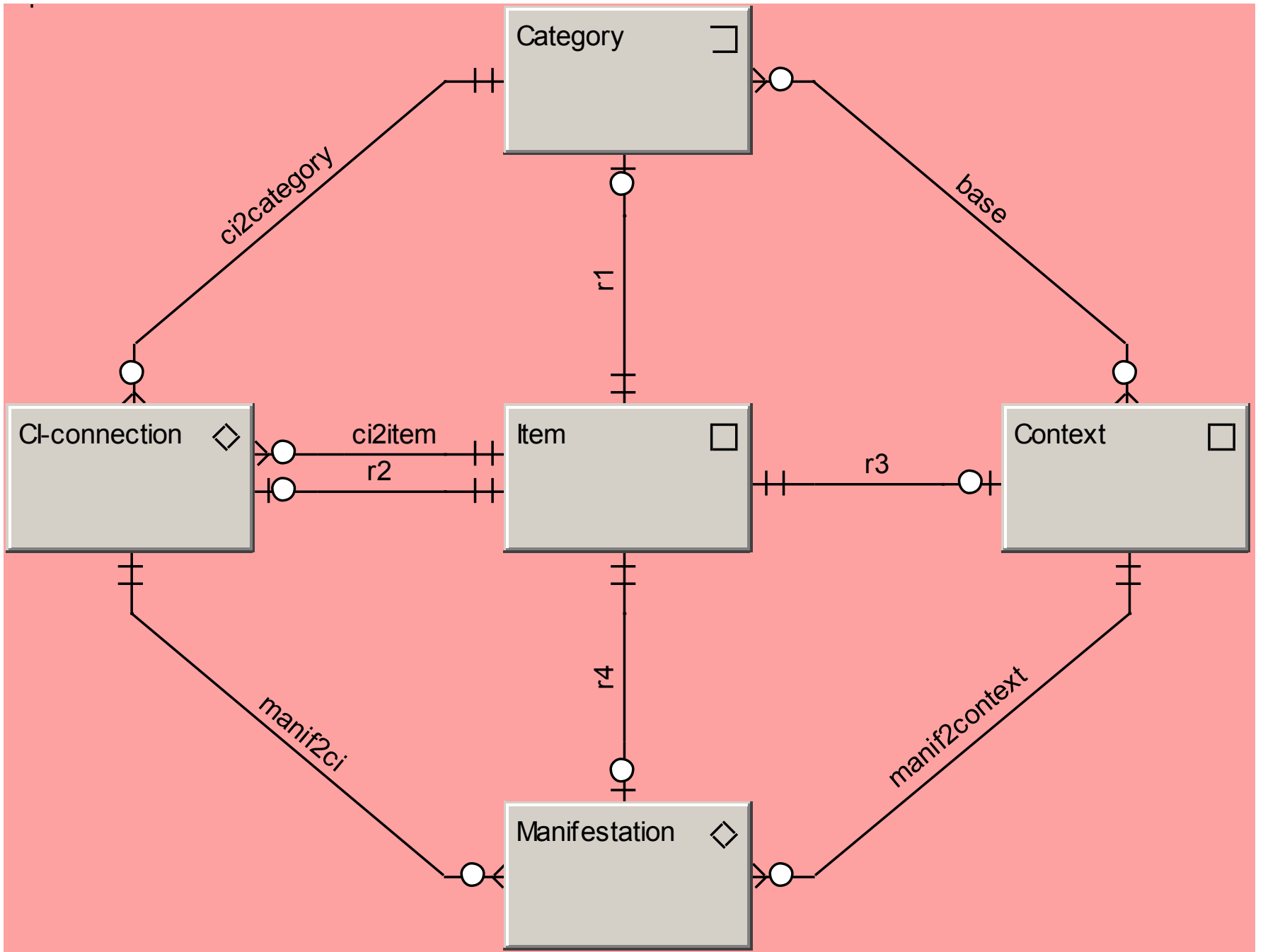


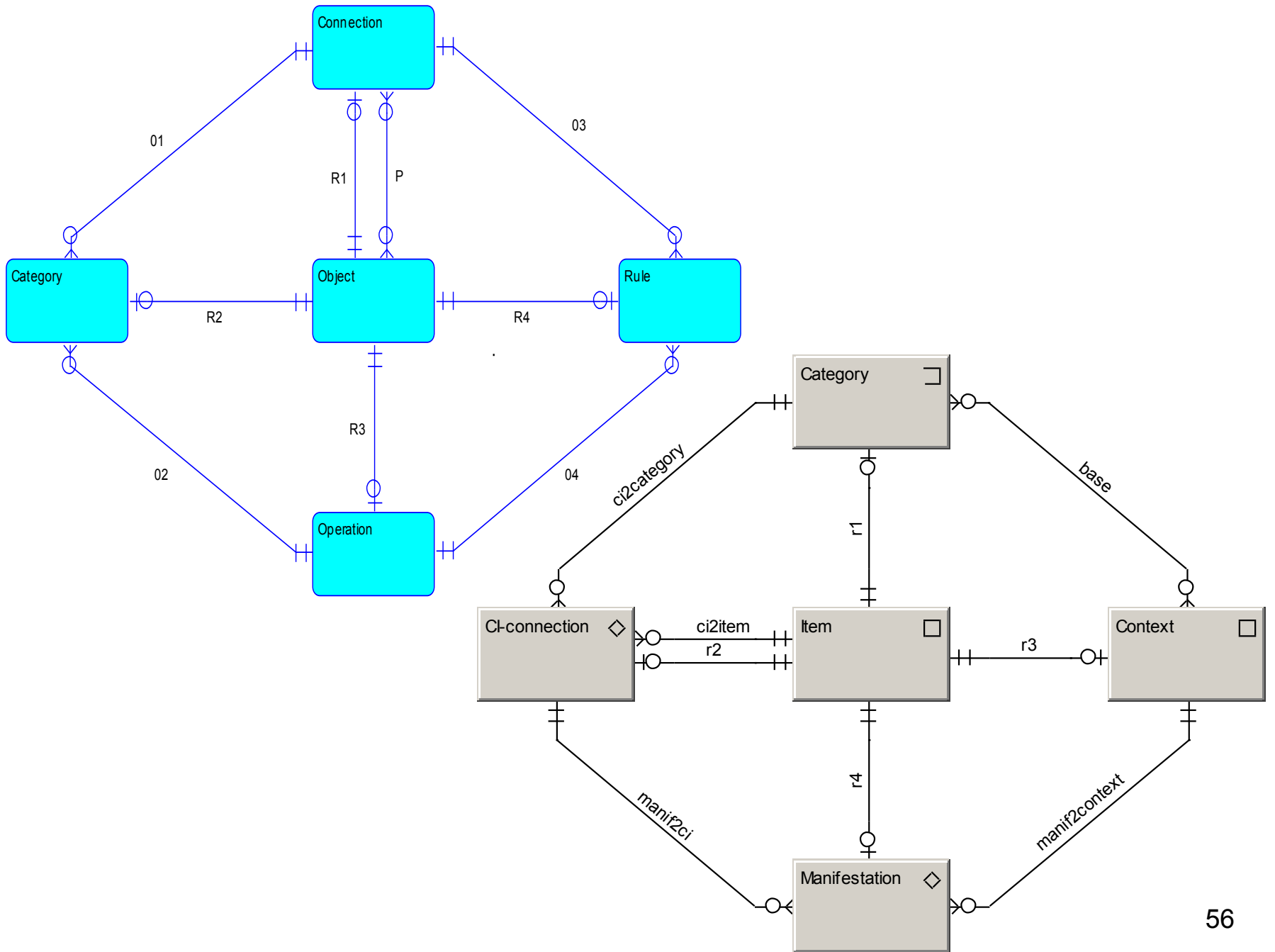
# Diamond of Cognition (Diam2)

In accordance with “enactive  
perception” principle:  
a way how “to **recognize**” effectively

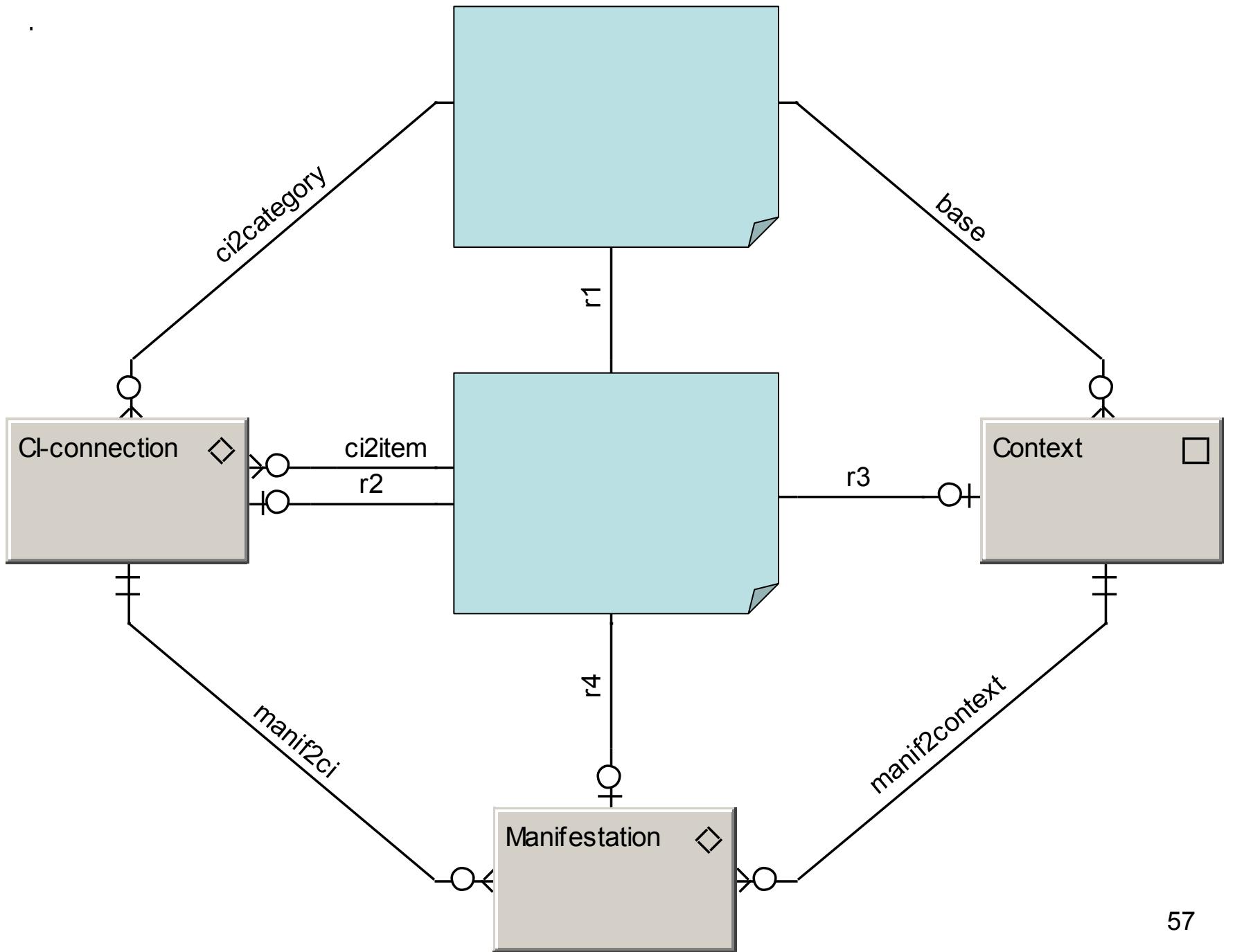
# Diamond of Cognition

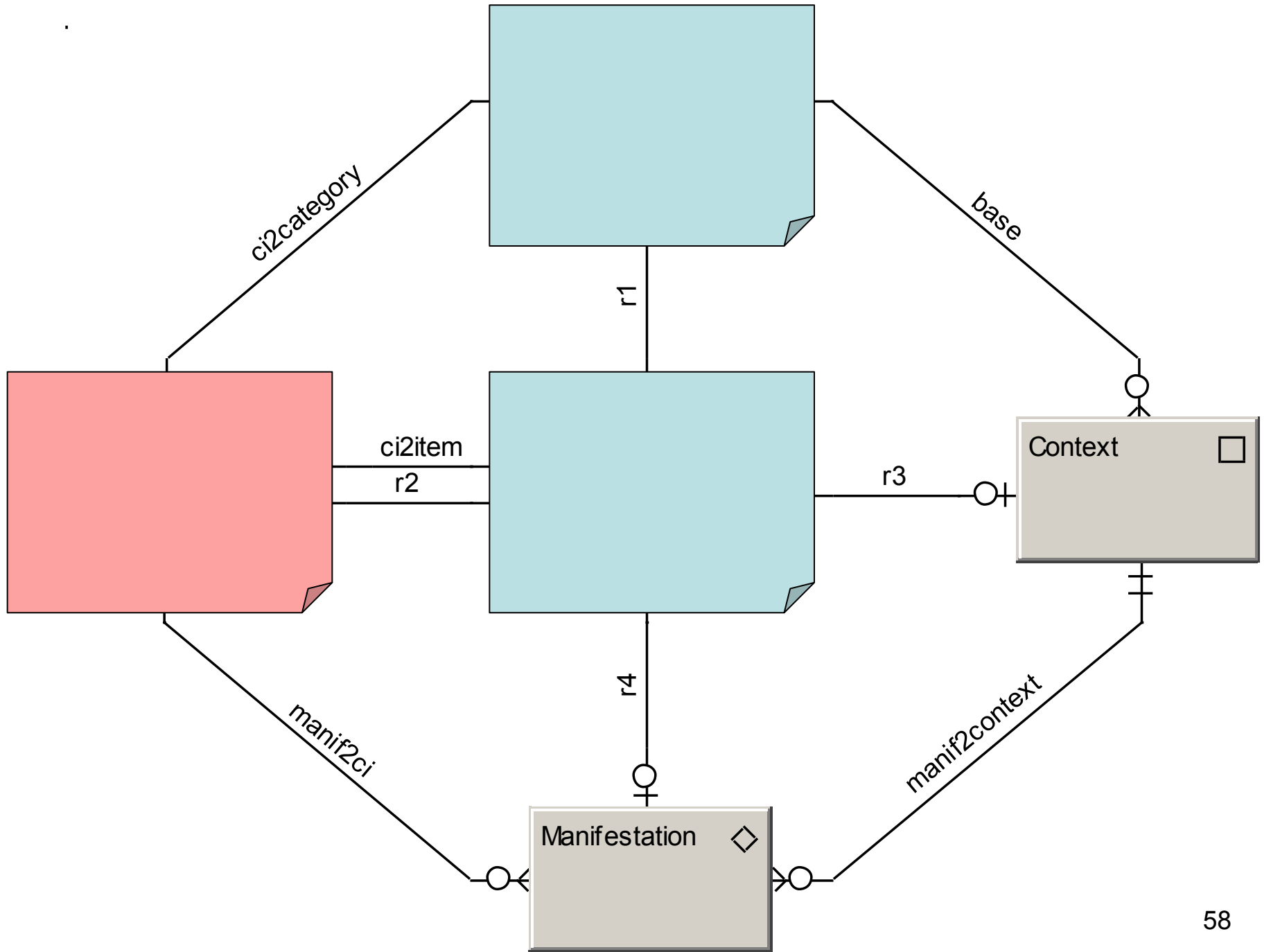
- Focus on Category
- Explicit work with Attention
- Explicit work with measure of certainty
- CI-connections manifested in a given context are “beliefs”.
- Beliefs are building blocks of our understanding of the World.

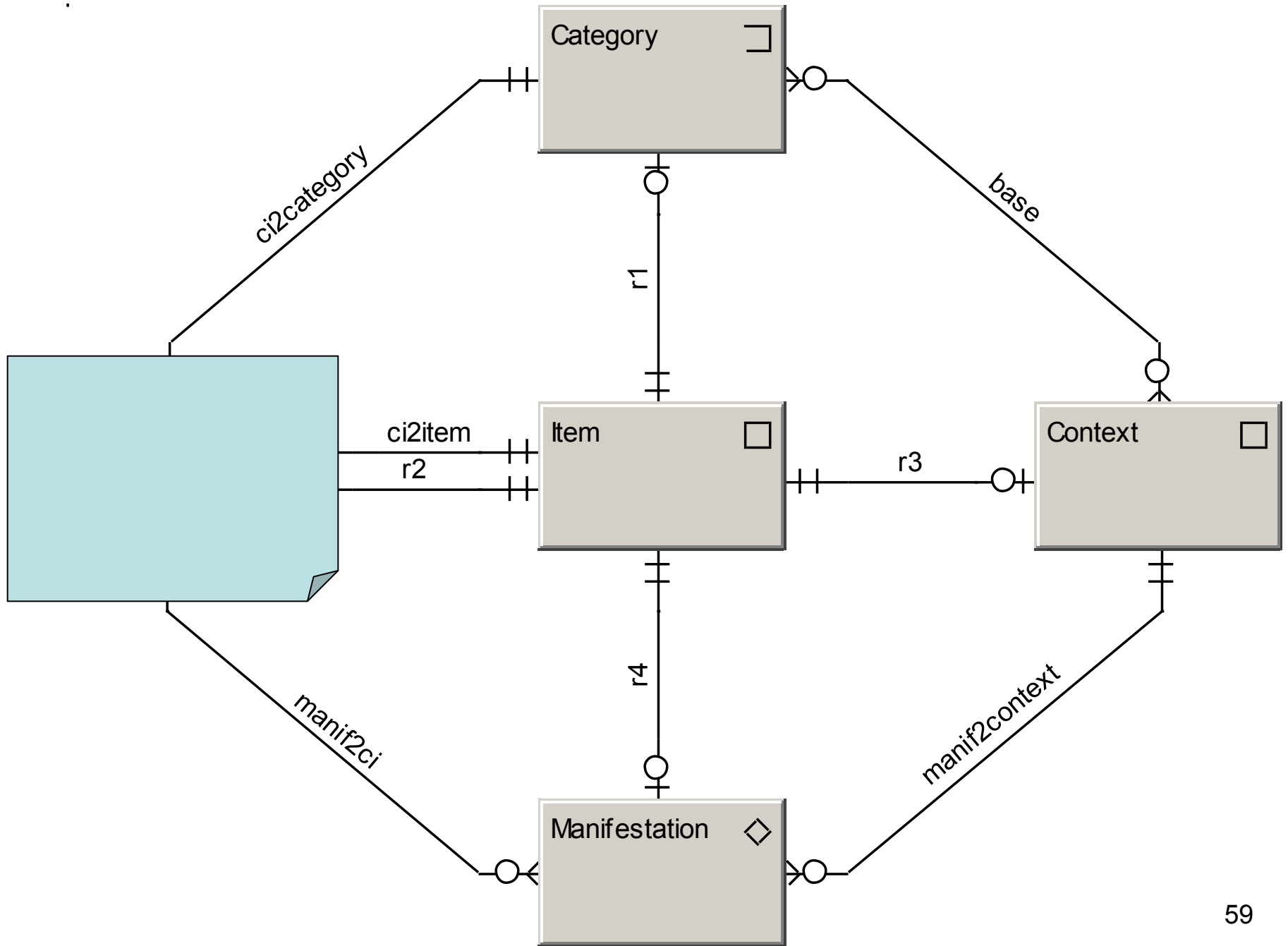


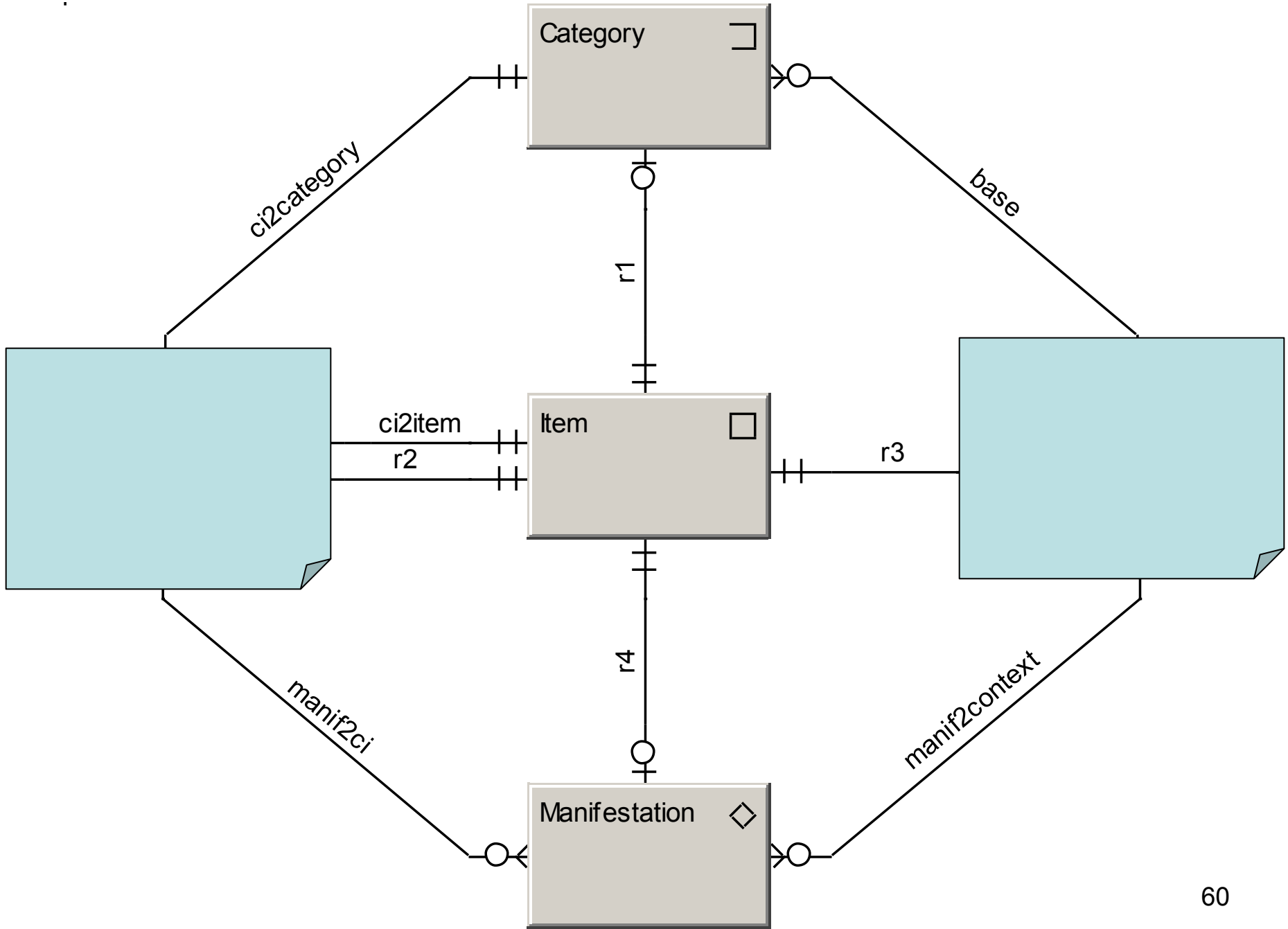


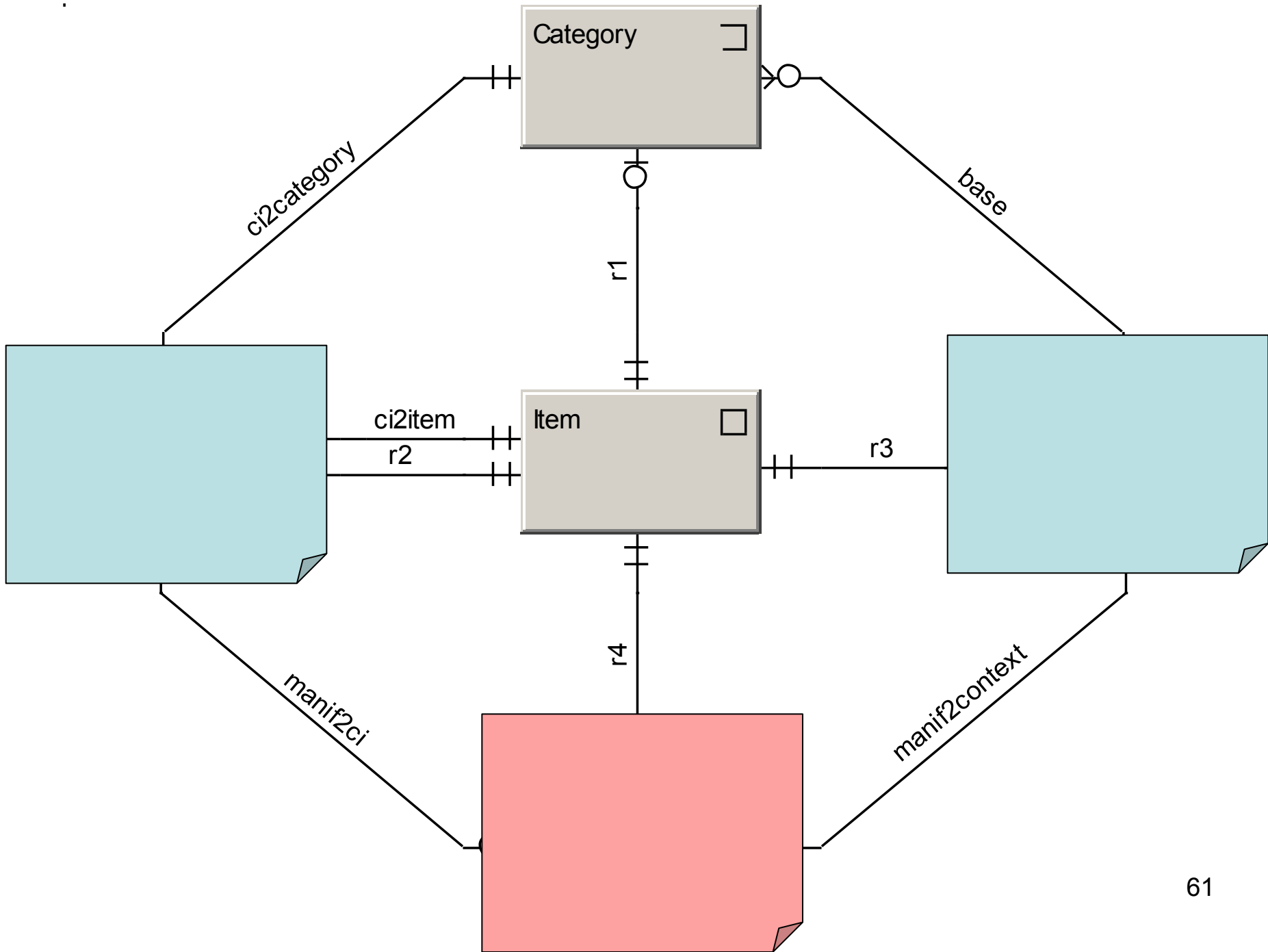




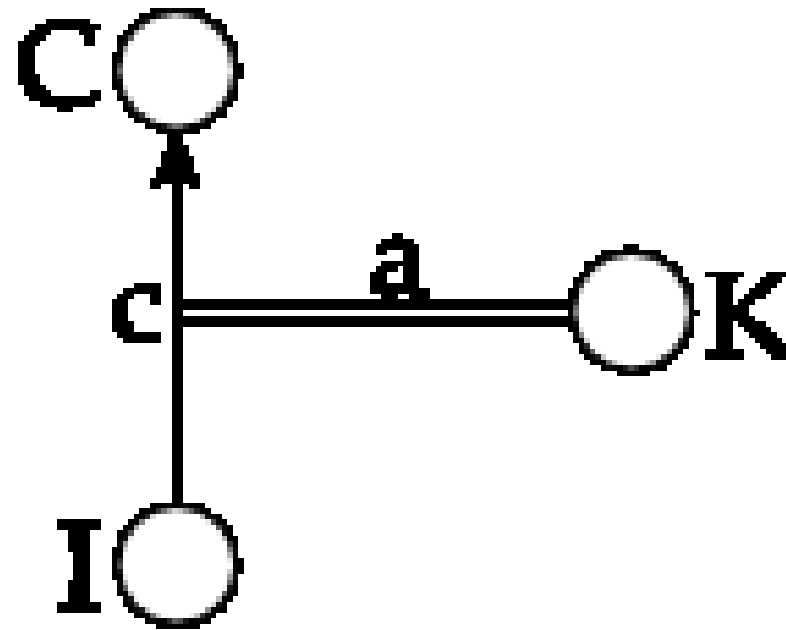






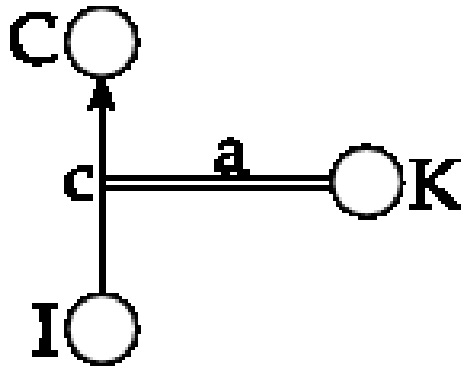


# The "T"



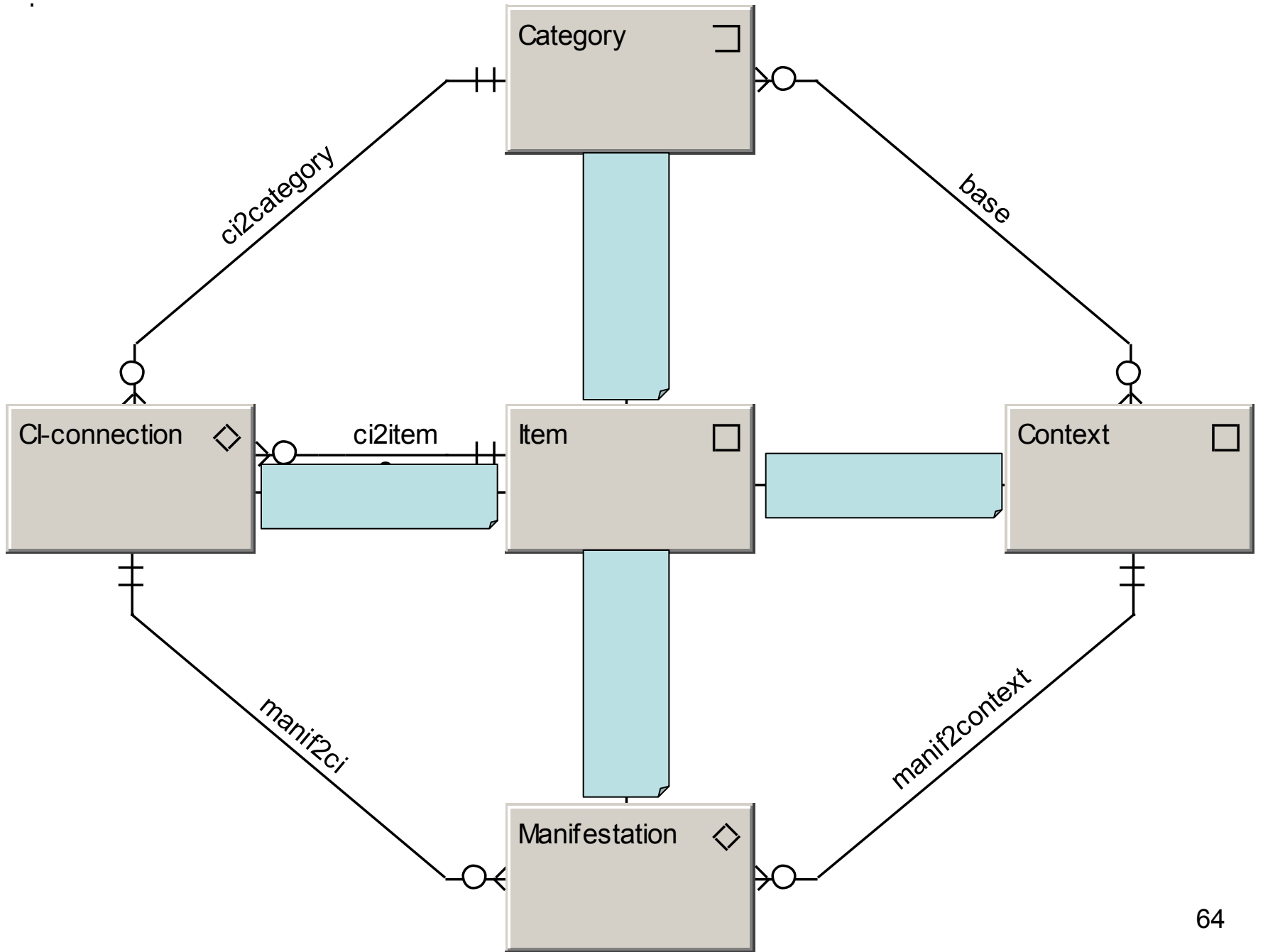
**Fig. 1: T (elementary belief)**

# Context

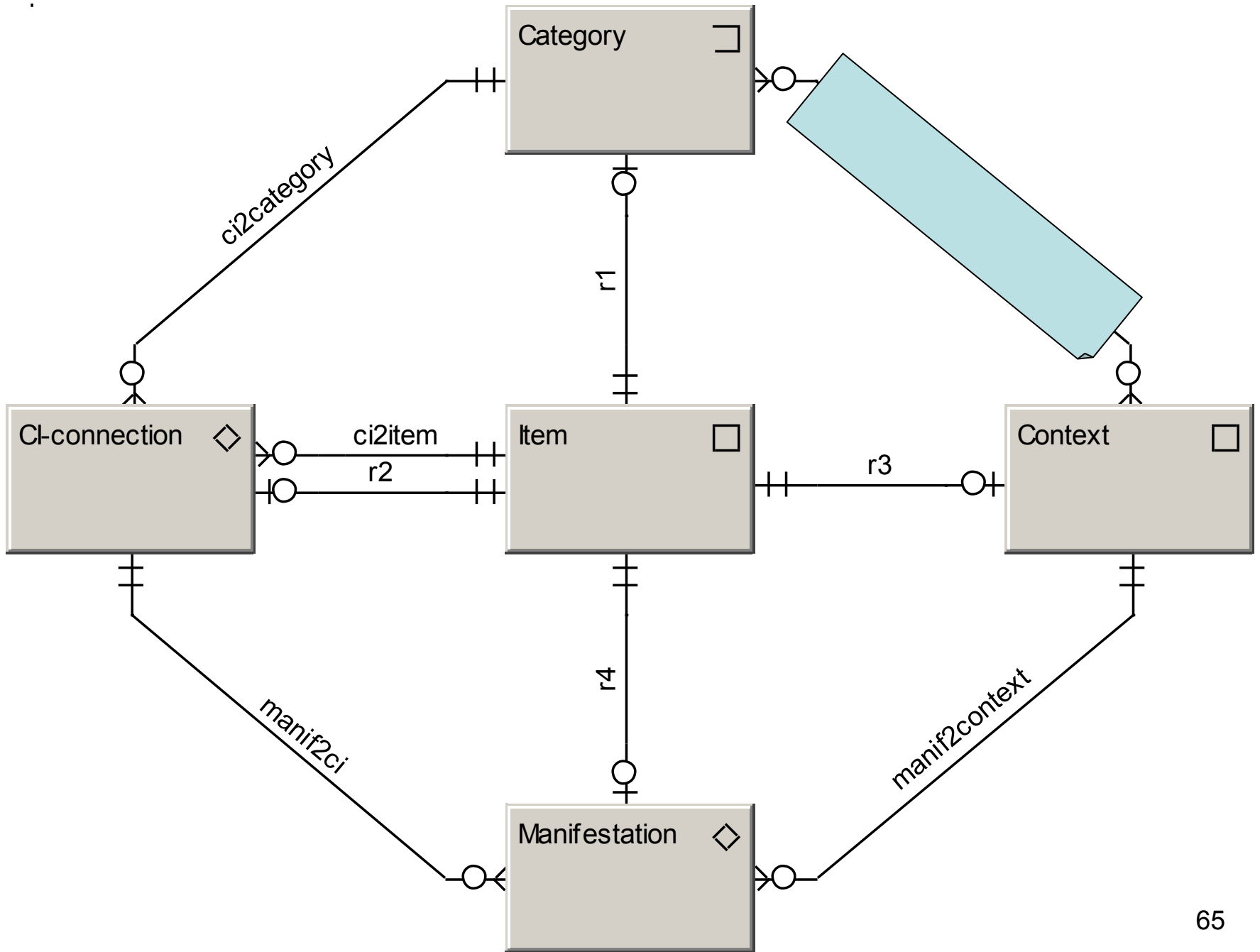


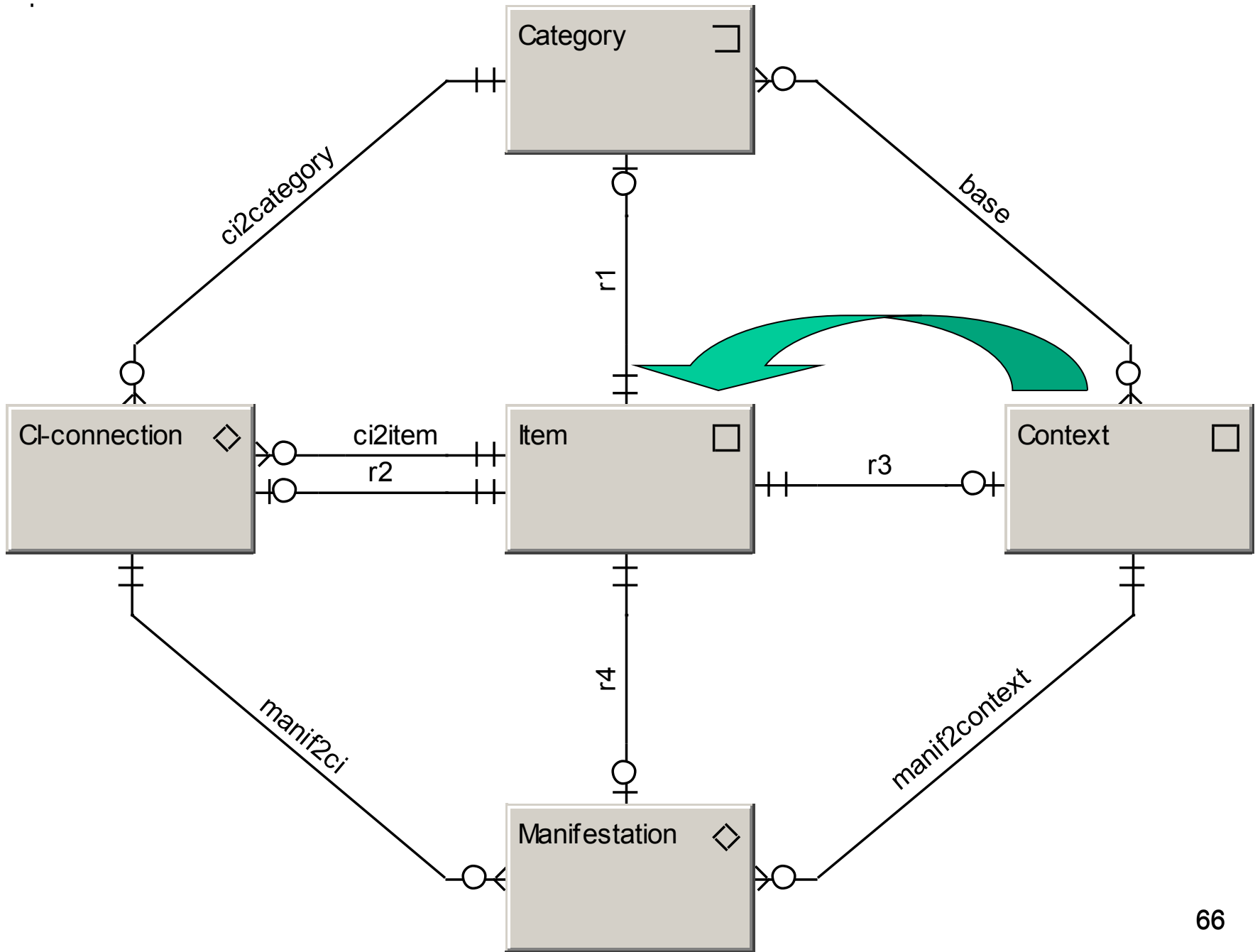
**Fig. 1: T (elementary belief)**

- $(I, C, c = 1, a = a_{\max})$  is a context.
- Let  $T_1, \dots, T_n$  be arbitrary elementary beliefs. Then  $(T_1, \dots, T_n)$ , i.e. a finite sequence of elementary beliefs, is a context.









# Context, Memory, Syplant

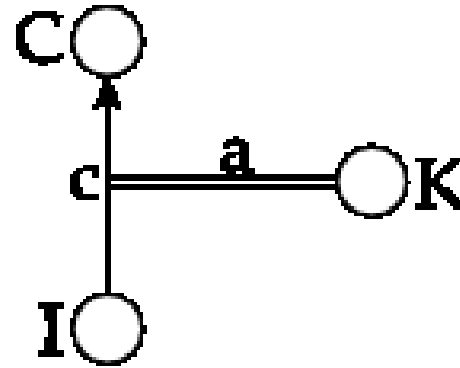
- Everything which is stored in **Memory** is a context.
- ... more precisely a hierarchy of contexts.
- Contexts grow as plants.
- As they could be seen as “semantics plants”, we call them ‘**syplants**’.
- Each such ‘**syplant**’ can be an image of a **domain**.
- To have a Type System in **one** domain makes no problem.
- To extend this Type System to **all** domains makes a problem!
- (The metaphor of Syplant could help understanding of cognition and semantics.)

# How to use this in practice?

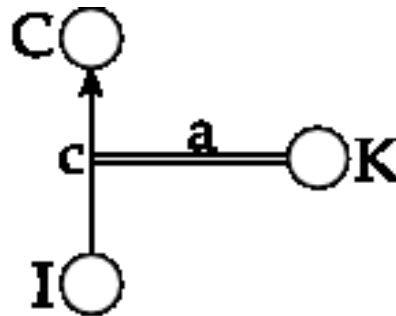
Is there a practical way to avoid issues originating in unique Type System utilization?

# Yes, it is ...

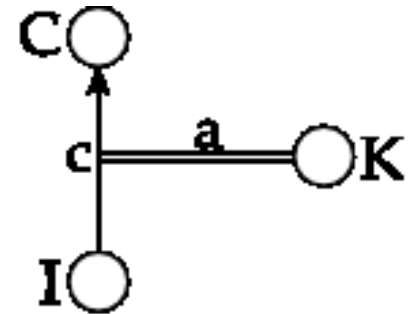
- You have to implement:
  - the “T”
  - Manifestation operation
  - Embedding the result of manifestation into the particular context



**Fig. 1: T (elementary belief)**



**Fig. 1: T (elementary belief)**



**Fig. 1: T (elementary belief)**

# What are the lessons learnt?

- We were faced (again) with the USE-mode of the Fundamental hierarchy. But: another point of view than in Diam1 !
- Now we cognize (!) HOW to compose complex beliefs from less complex beliefs ...  
... and from elementary beliefs.
- **A complex belief is composed of elementary beliefs; each of them in turn can be a complex one.**

