

Dějiny Řecka I. seminář

4. TÉMA OLYMPIE A OLYMPIJSKÉ HRY



Greece and the Aegean during the Dark Ages (12th – 9th cents. BC); the most important sites

- | | | |
|---|---|-------------------------------------|
| ● Important settlement | Chronology: | Finding - places of imported goods: |
| ○ Settlement (with / without architectural finds) | ▢ Late Helladic (12th / early 11th cents.) | ┃ Orient |
| ⌂ Necropolis / tomb | ▢ Sub - Mycenaean / Sub - Minoan (early - mid 11th cent.) | ⌘ Cyprus |
| ⌂ Sanctuary | ▢ Proto - geometric (mid 11th cent. – c. 900 BC) | ⌘ Italy, Europe |
| ⌂ Centre of pottery production | ▢ Geometric (Early, Middle) (9th – early 8th cents.) | Mykenai Ancient name |
| ? ⌂ Identification uncertain | ▢ Dating certain / uncertain | Çömlekçi Modern name |
| | | (Rhodos) Island |



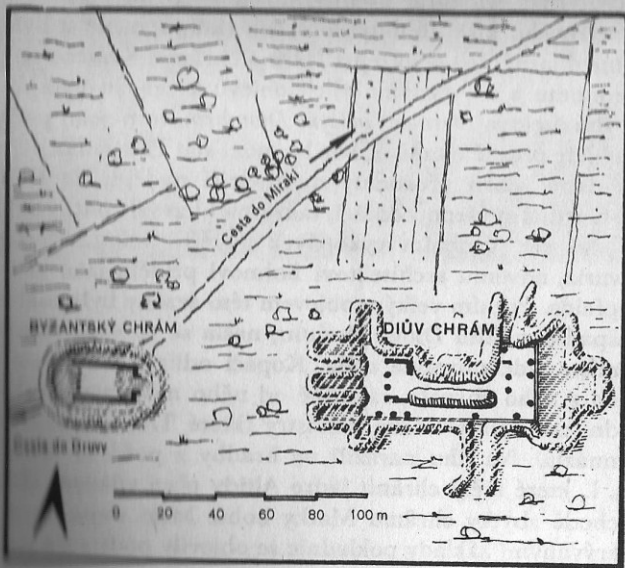

*Vykopávky v Olympii.
Vlevo stav po
francouzských výkopech
roku 1829, vpravo po
dvou sezónách
německých výkopů roku
1887. Poloha stadiónu
a jiných sportovních
staveb nebyla tehdy ještě
známa*

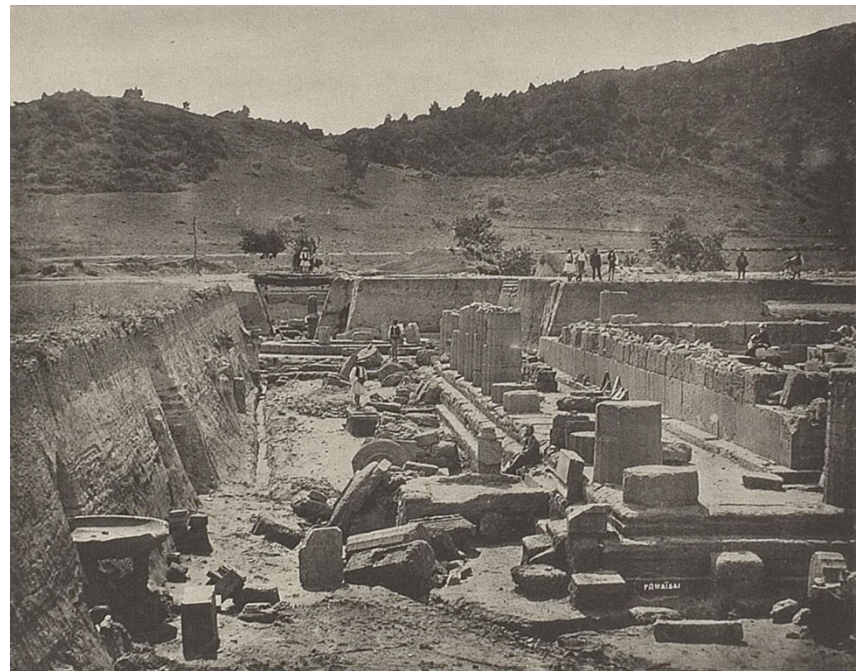
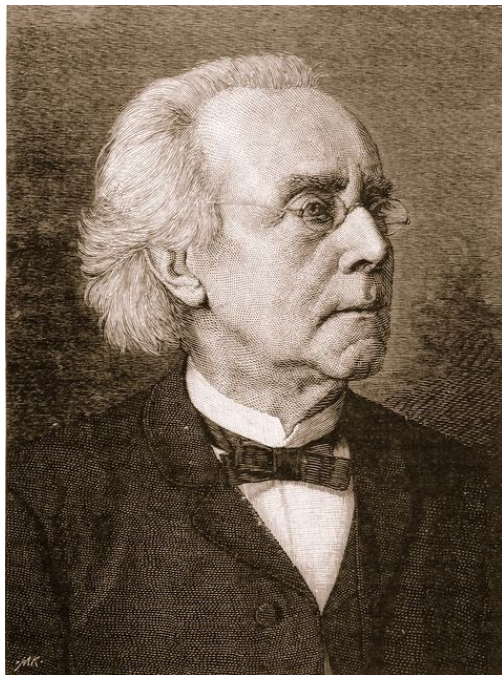
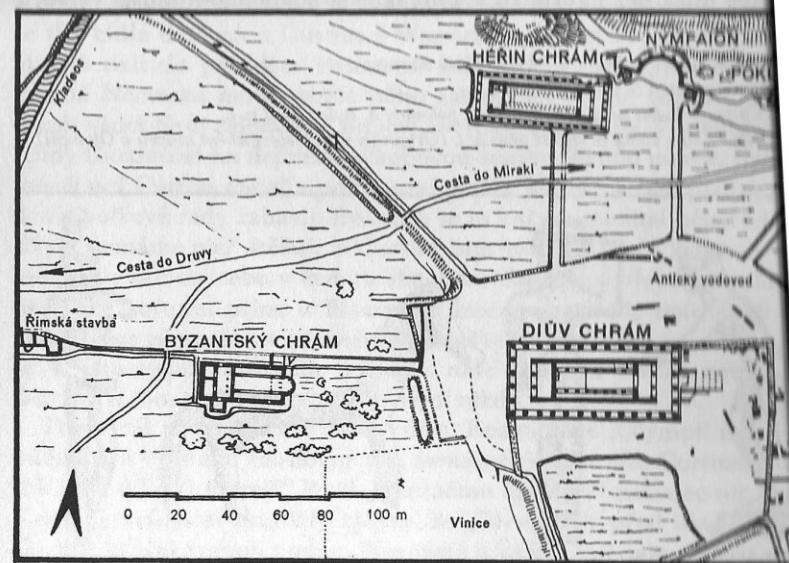

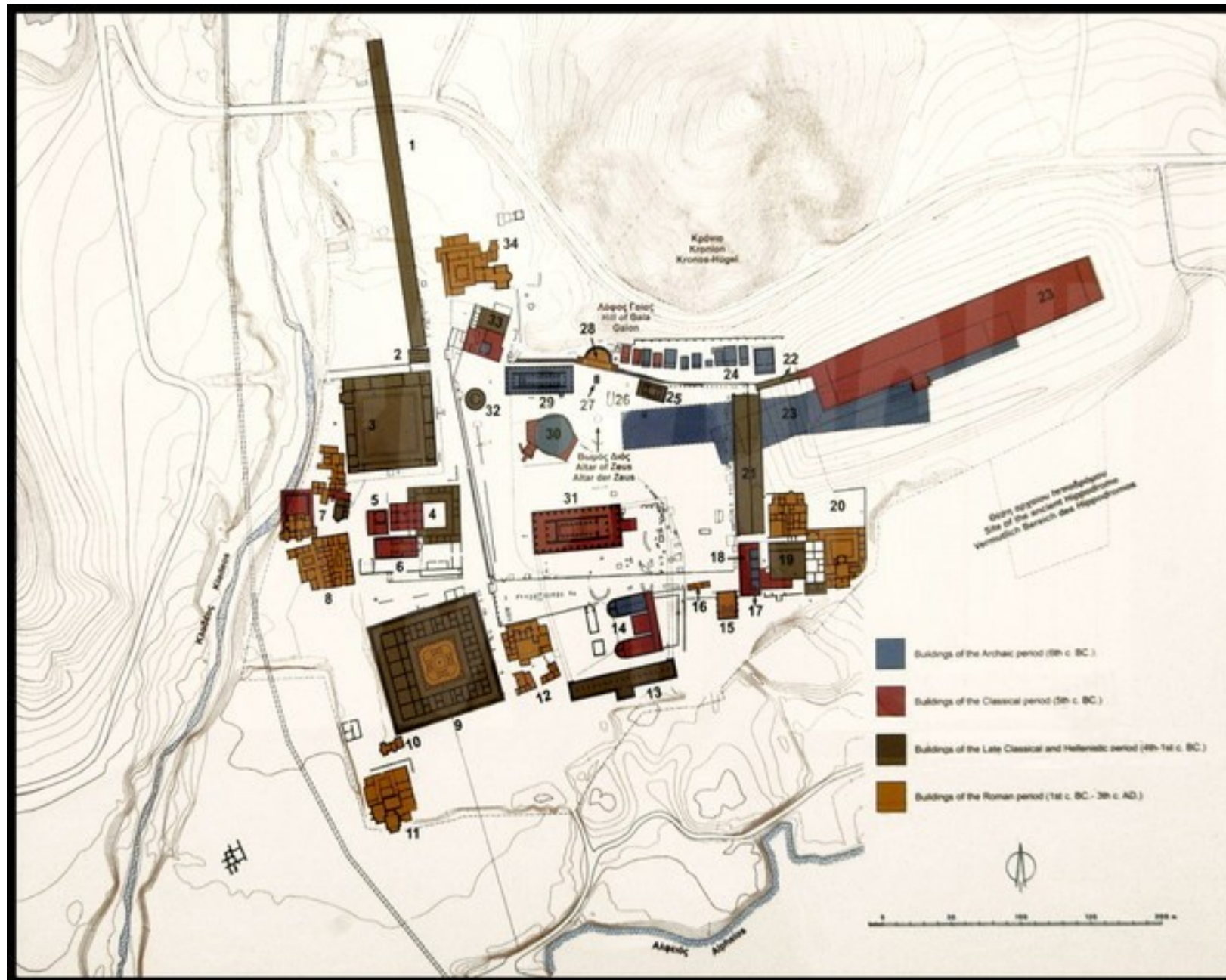

- 1. Gymnasium
- 2. Propylon
- 3. Palaestra
- 4. Theokleion
- 5. Heron
- 6. Pheidias' workshop
- 7. Kladeos baths
- 8. Roman Guest Accomodation
- 9. Leonidion
- 10. Ἰδρυτὶς Ἀσπιδοβόλου
- 11. SW Baths-Athlet's Club
- 12. Southern Baths
- 13. Southern Colonnade
- 14. Bouleuterion
- 15. Odeion
- 16. Arch of Nero
- 17. Sanctuary of Hestia
- 18. SE building
- 19. Greek Building
- 20. Octagon
- 21. Echo Colonnade
- 22. Krypte
- 23. Stadion
- 24. Treasuries
- 25. Metroon
- 26. Prehistoric apsidal building II
- 27. Altar of Hera
- 28. Nymphaion
- 29. Herain
- 30. Pelopion
- 31. Temple of Zeus
- 32. Philopion
- 33. Pnythion
- 34. Building of a Roman House



An aerial view of Olympia, Greece





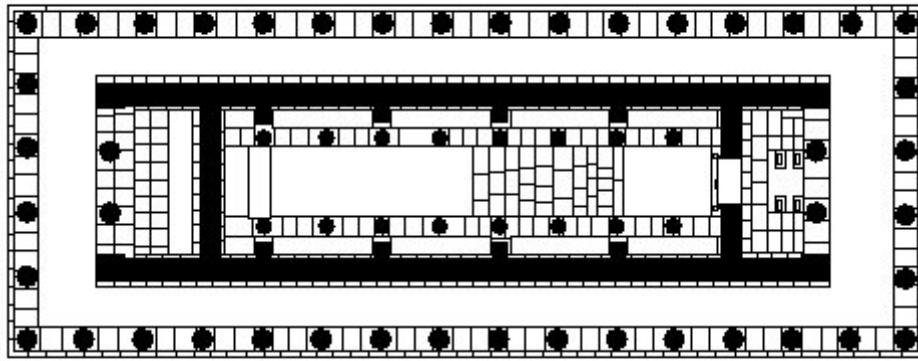

0 1 10 m. ↑







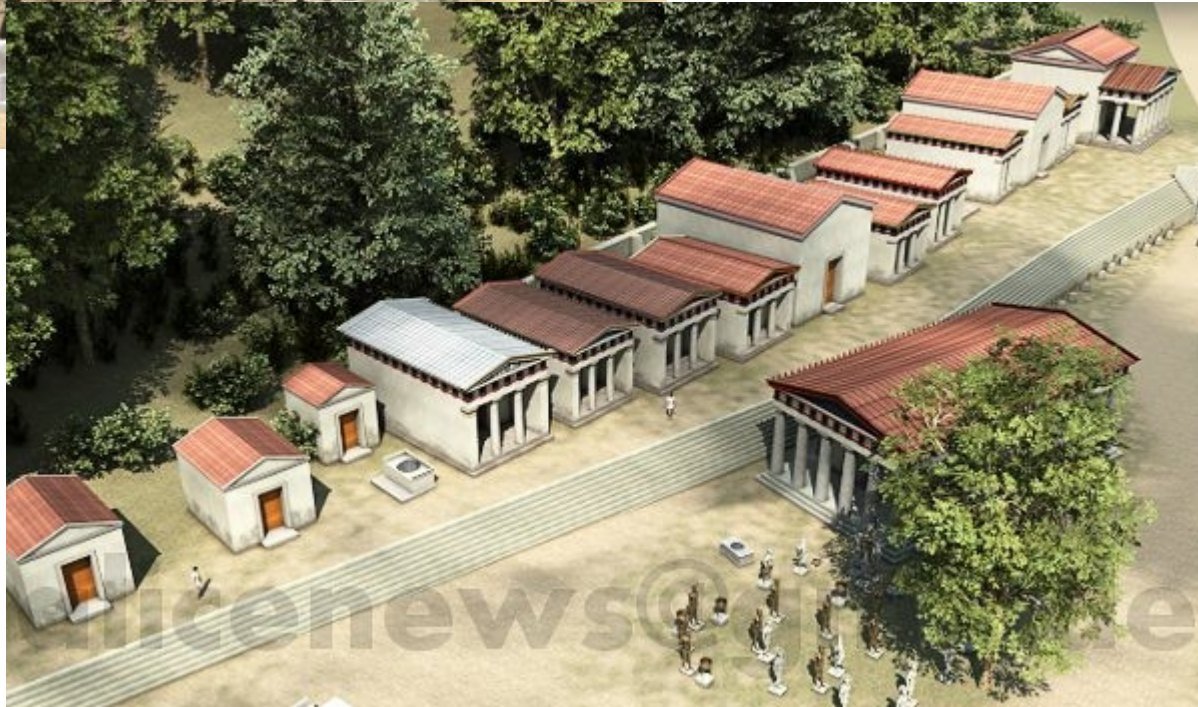
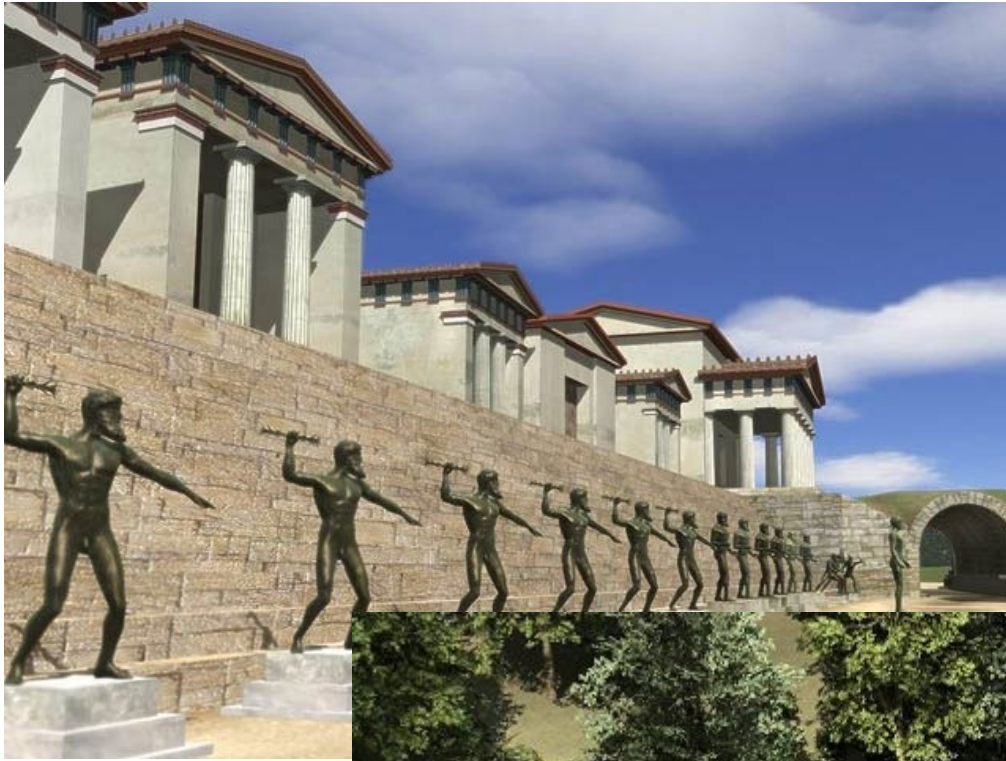

Olympia, Pelopeion

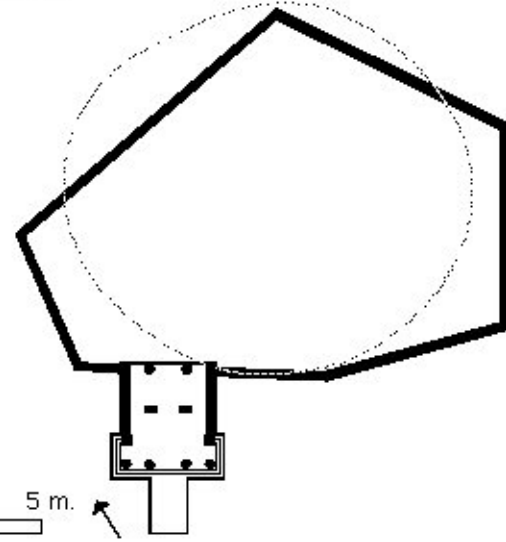
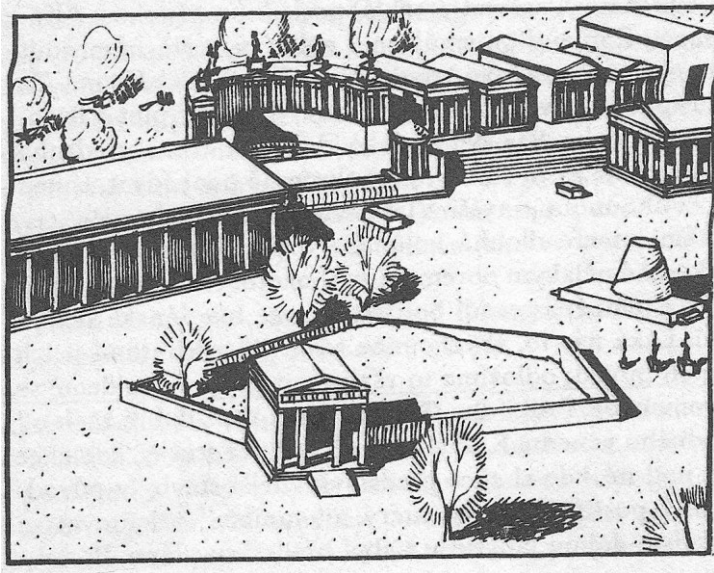



Olympia, Bouleuterion

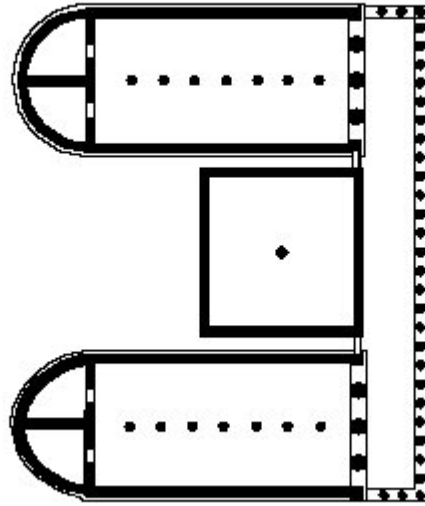

0 10 m.



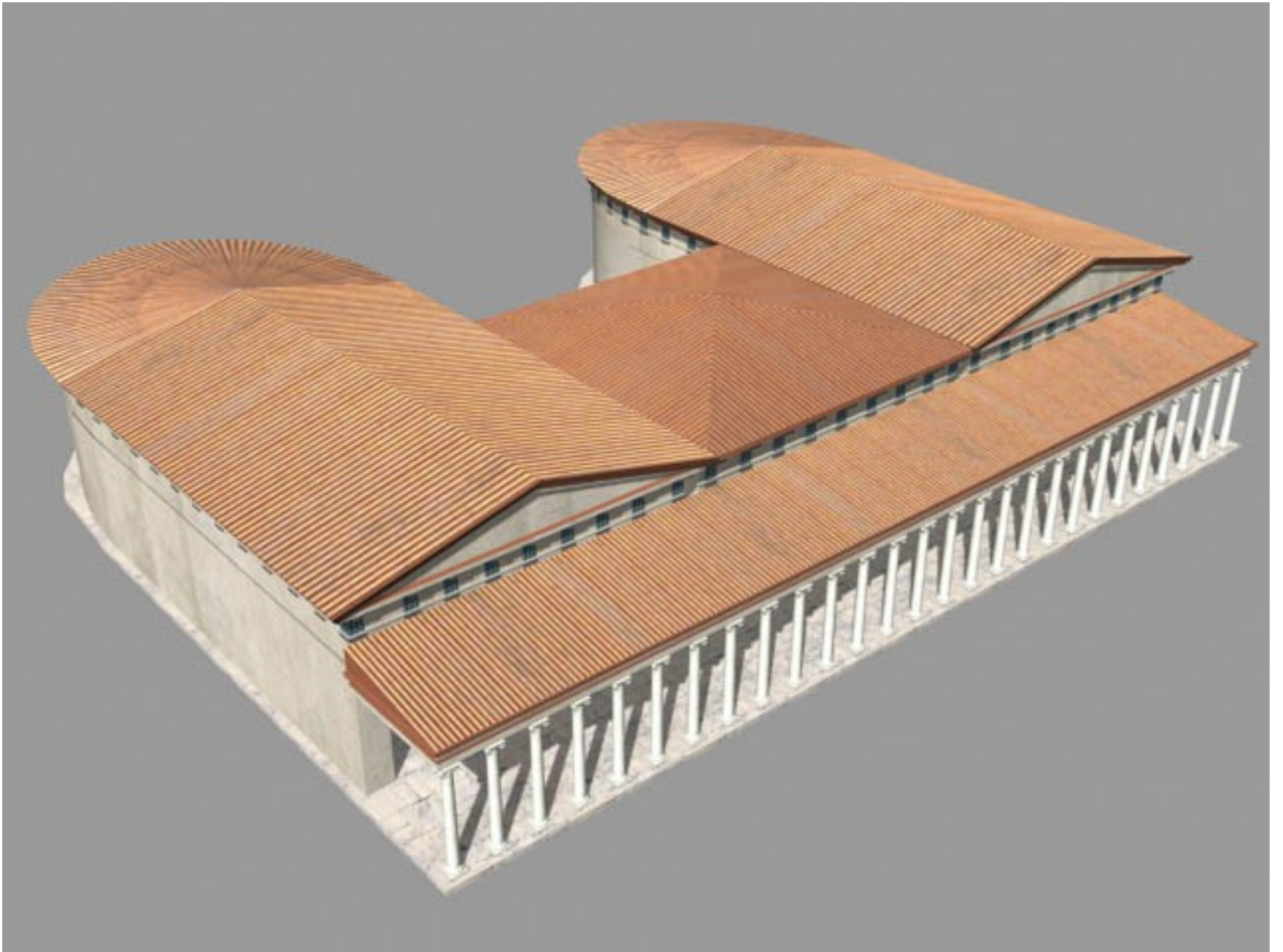

Olympia, Temple of Zeus

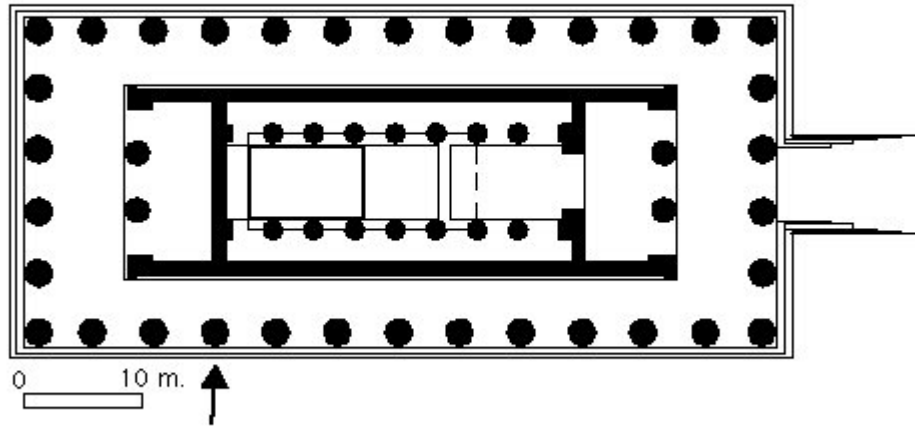





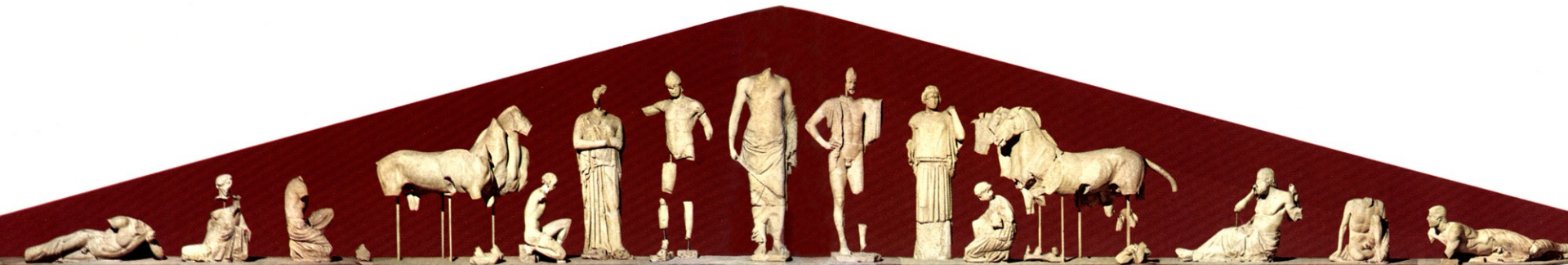

Alpeios or Kladeos Diviner Charioteer Horses from Oinomaos' or Pelops' chariot Kneeling youth (Myrtilos?) Sterope or Hippodameia Pelops Zeus Oinomaos Hippodameia or Sterope Kneeling girl Horses from Oinomaos or Pelops' chariot Old diviner (Iamos?) Crouching youth (possibly Arkas) Kladeos or Alpeios





Lapith woman Old Lapith woman Lapith Centaur Lapith woman Centaur and Lapith Theseus Centaur Lapith woman Apollo Deidameia and Centaur Eurytion Peirithoos Lapith and Centaur Lapith woman and Centaur Lapith Old Lapith woman Lapith woman

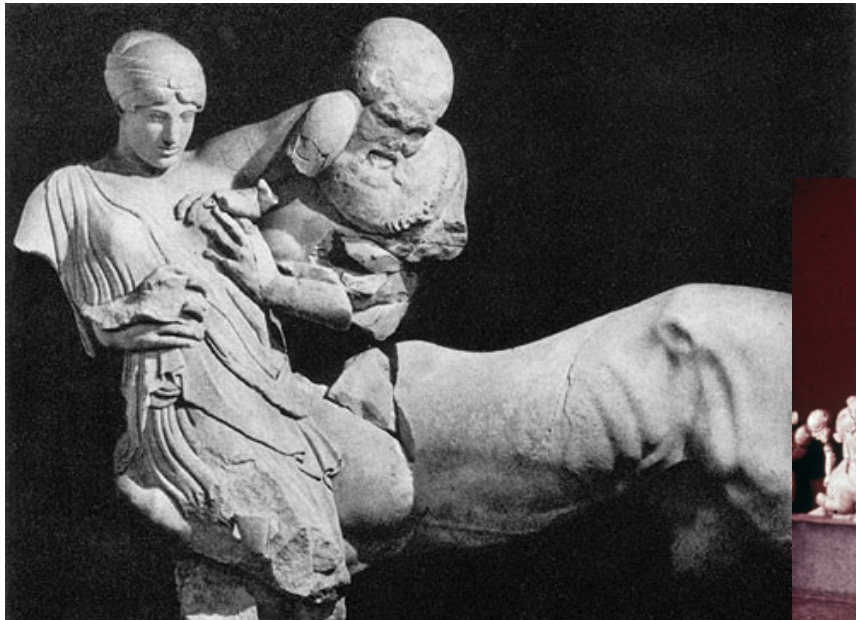

Athena

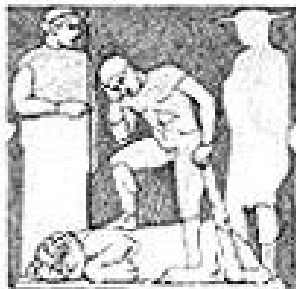

Athena

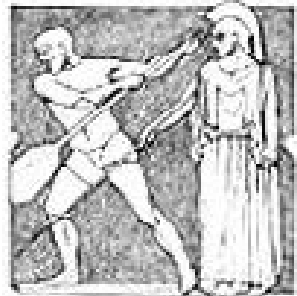
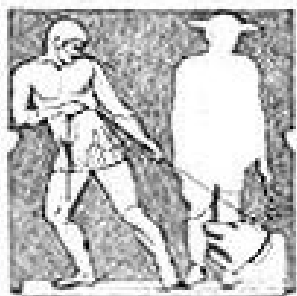
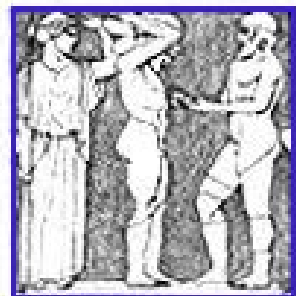
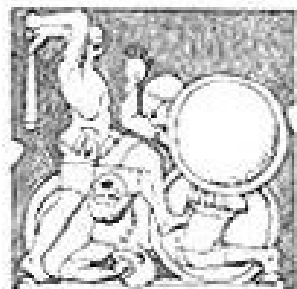
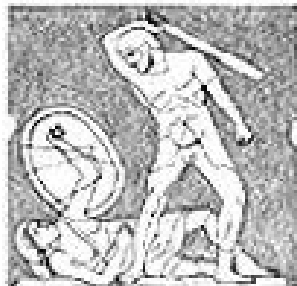
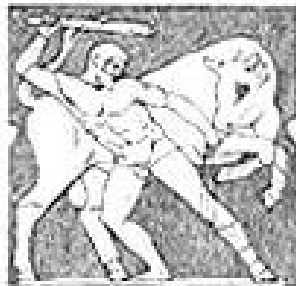
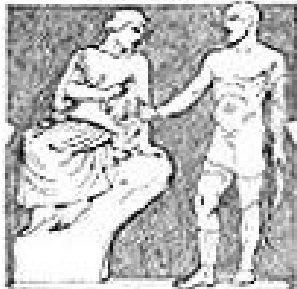

Athena

Athena







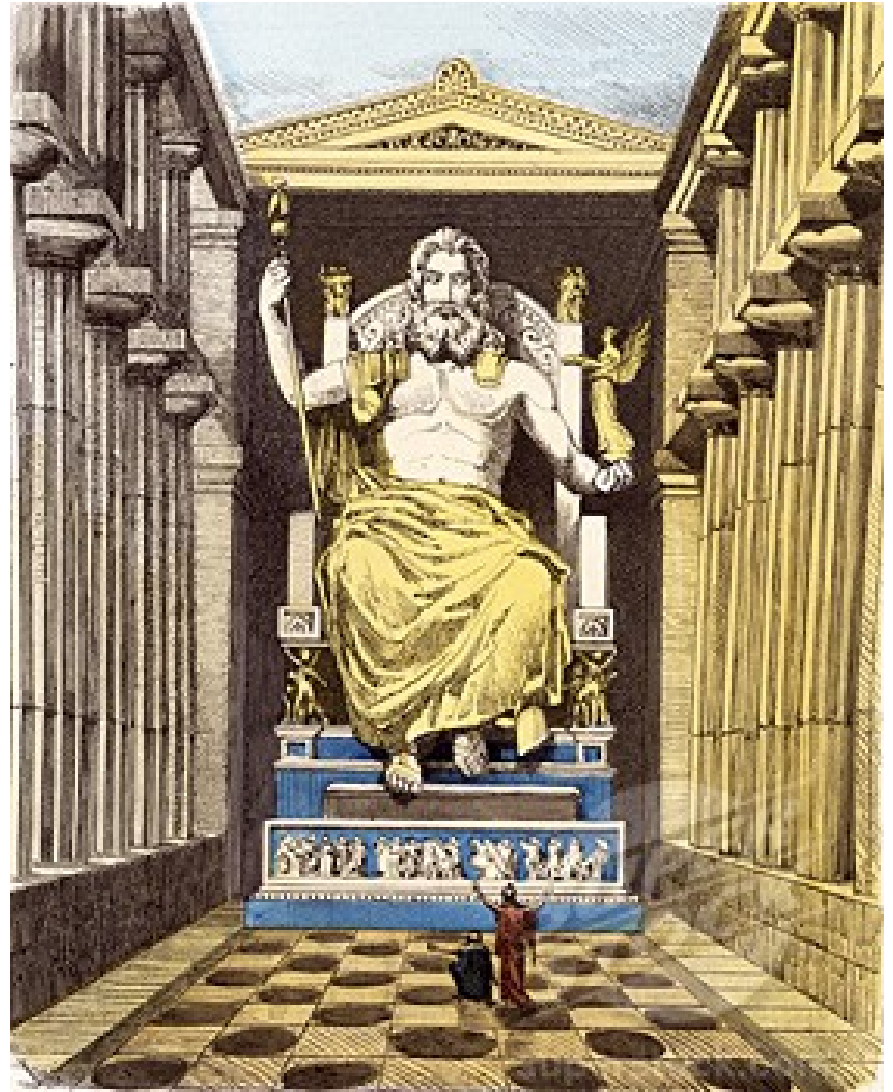



Olympia, Metroon

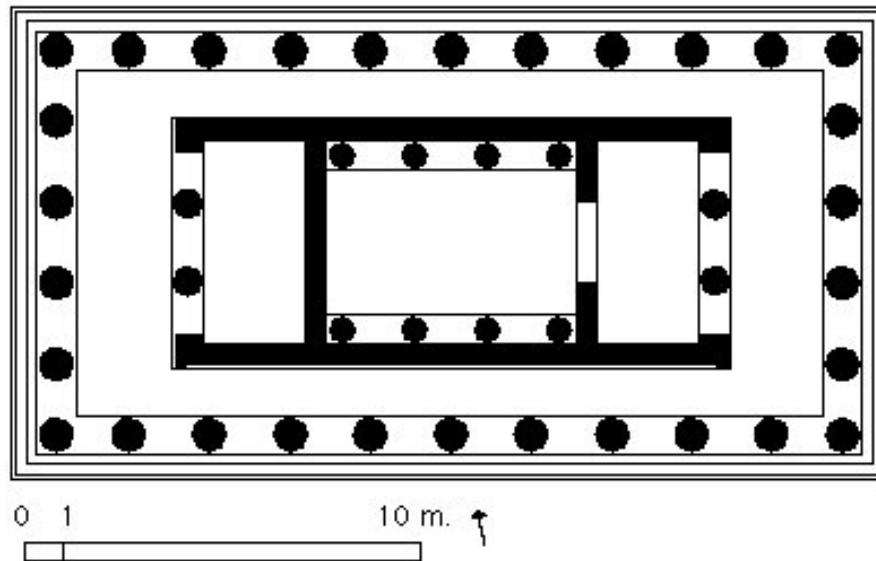



ח

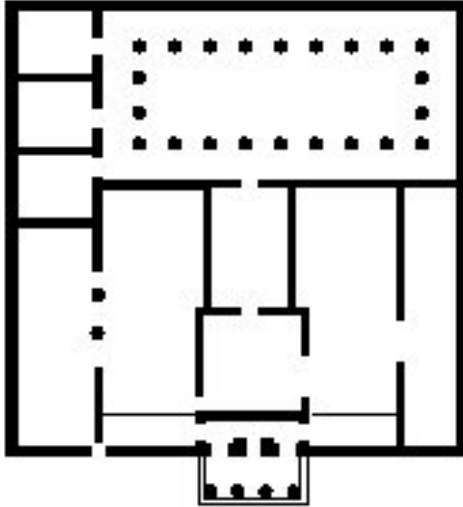

0 10 m.



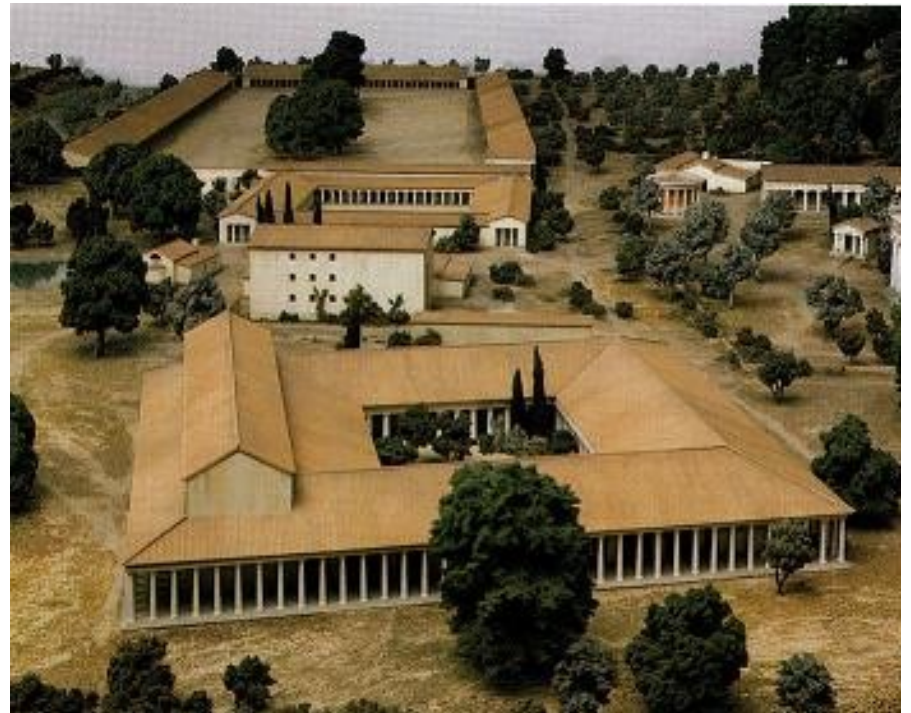
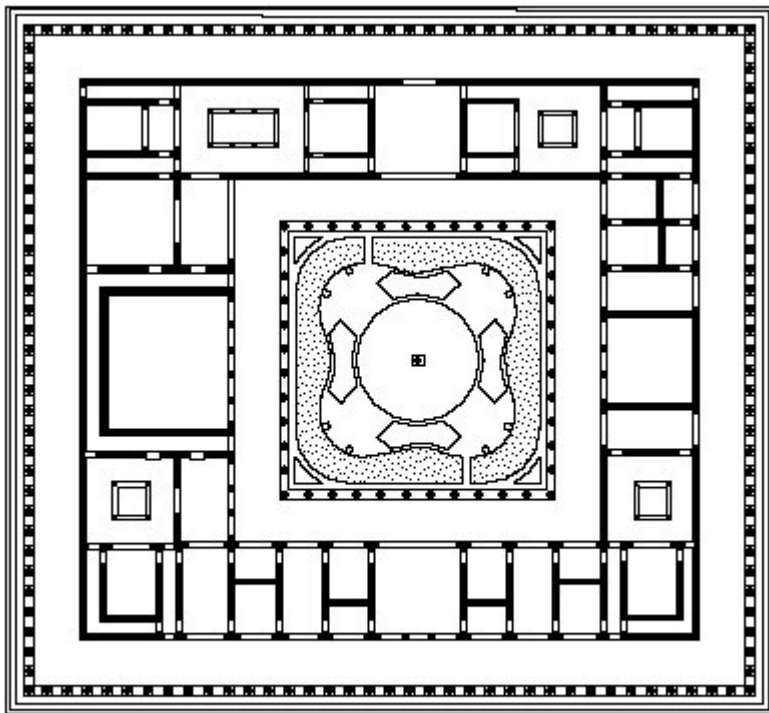

Olympia, Echohall (Painted Stoa)

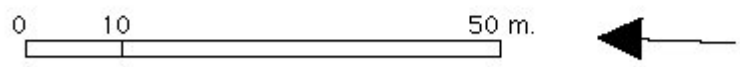
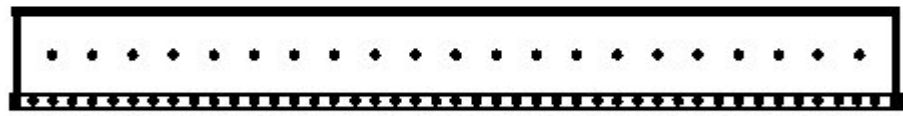

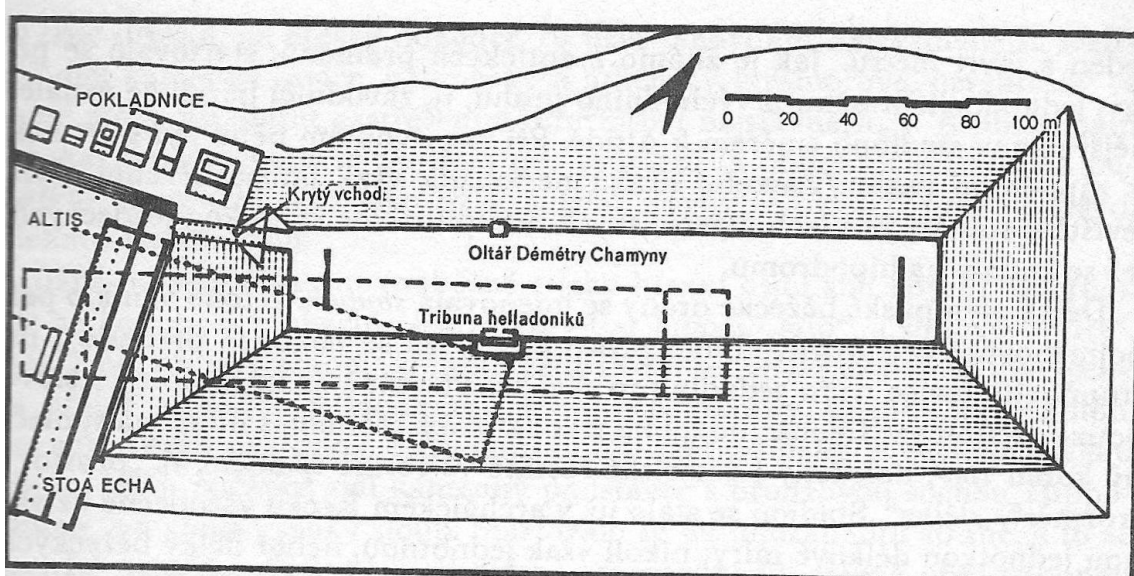

© shunya.net



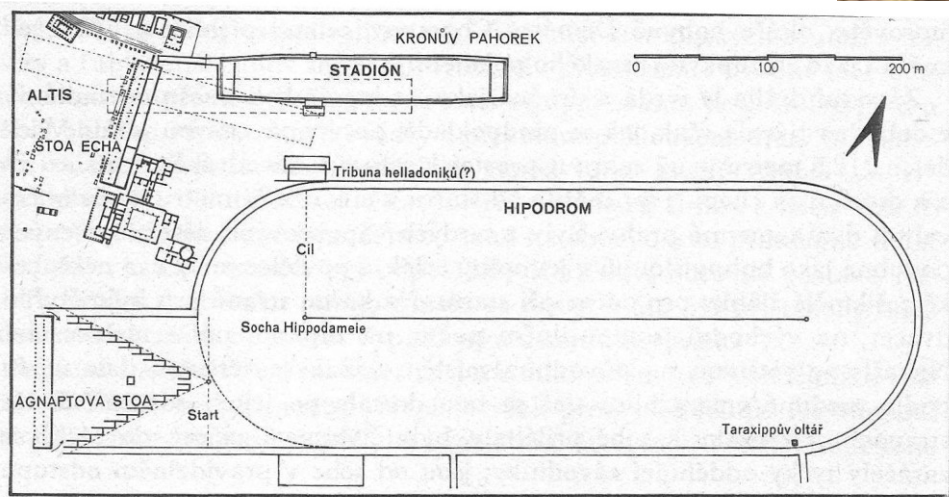
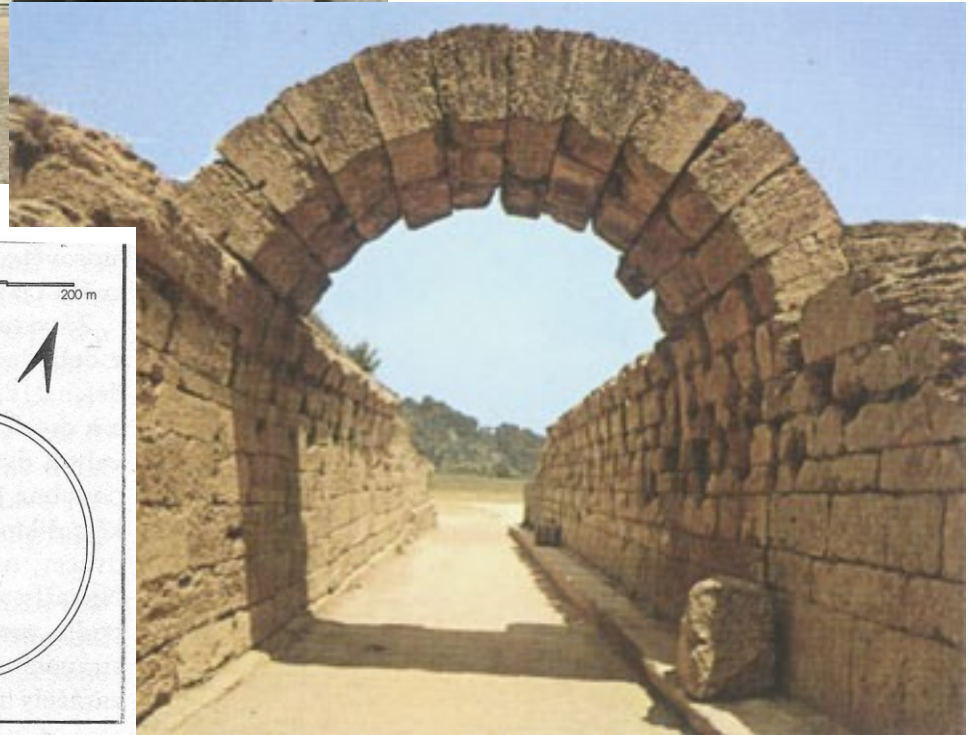

Olympia, Philippeion

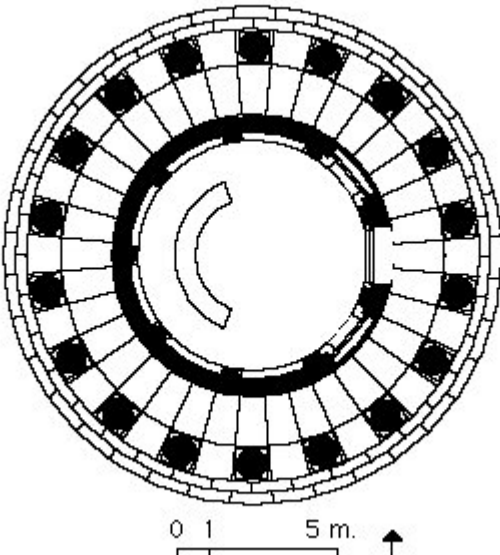

Olympia, Palaestra

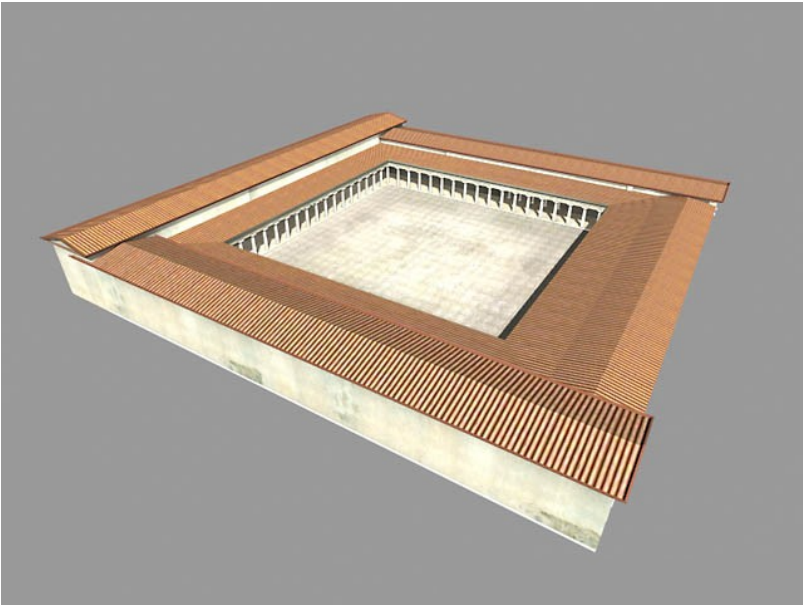
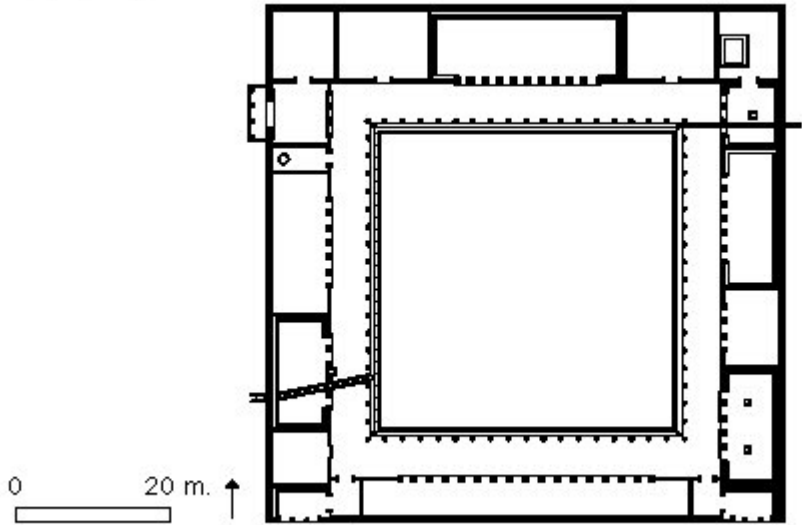

Olympia, Gymnasium

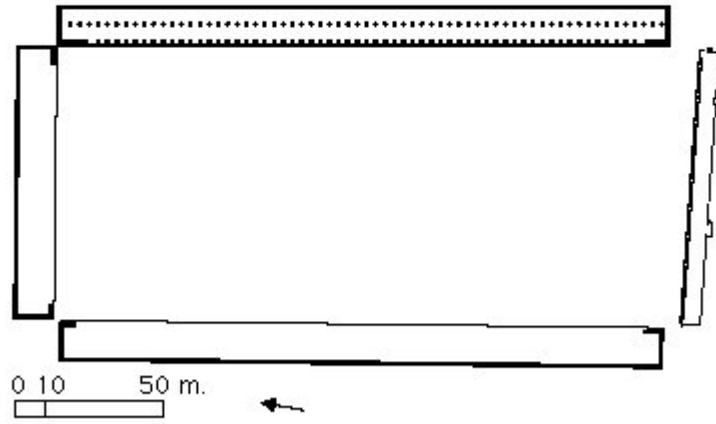

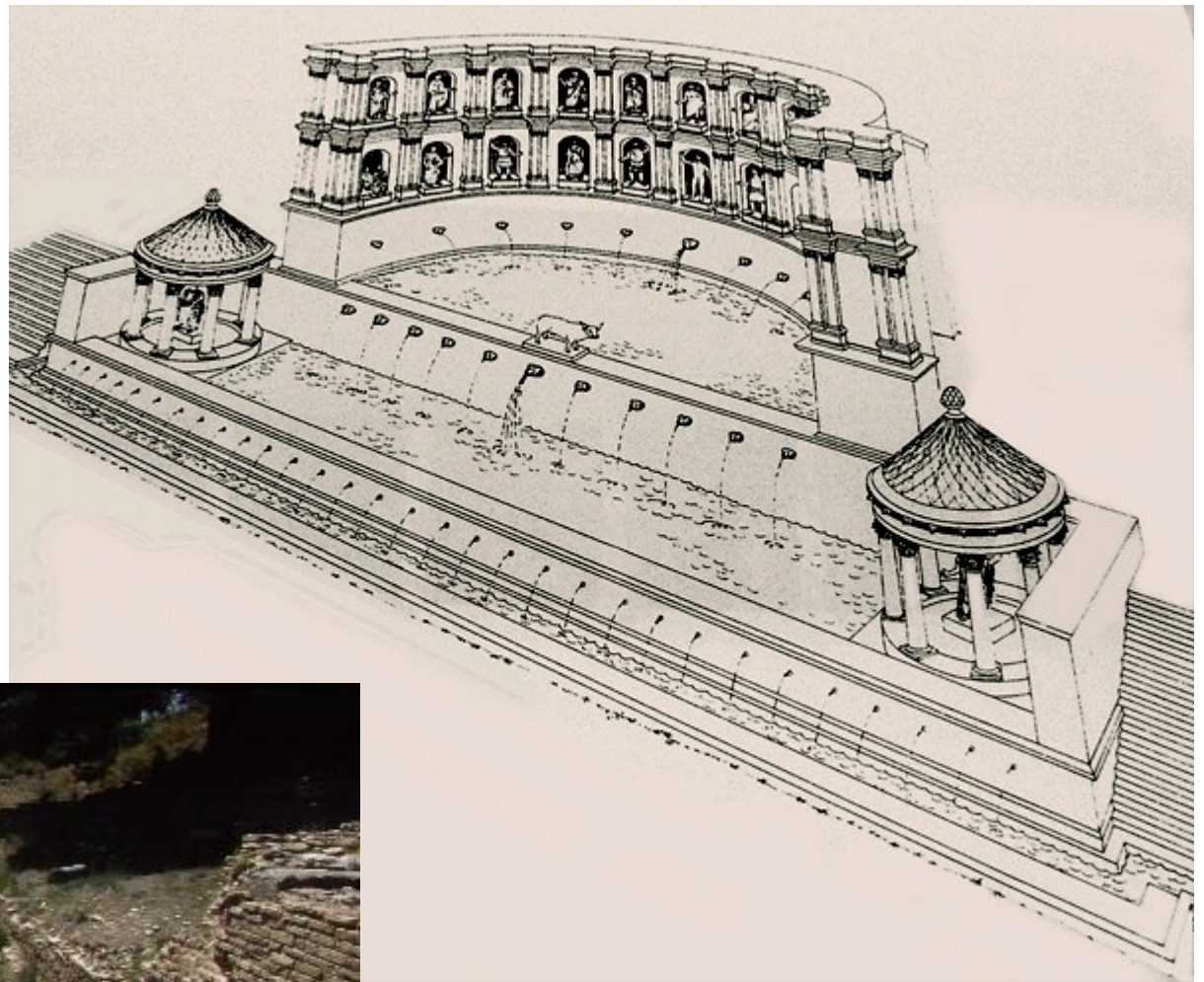



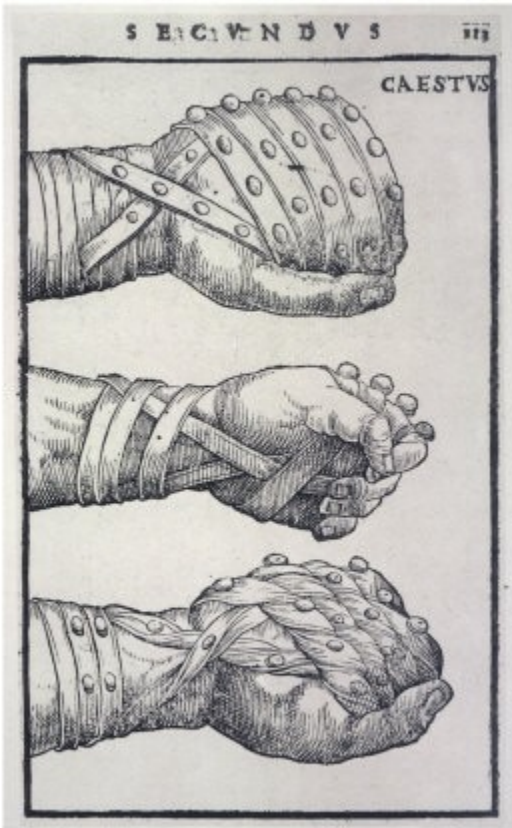
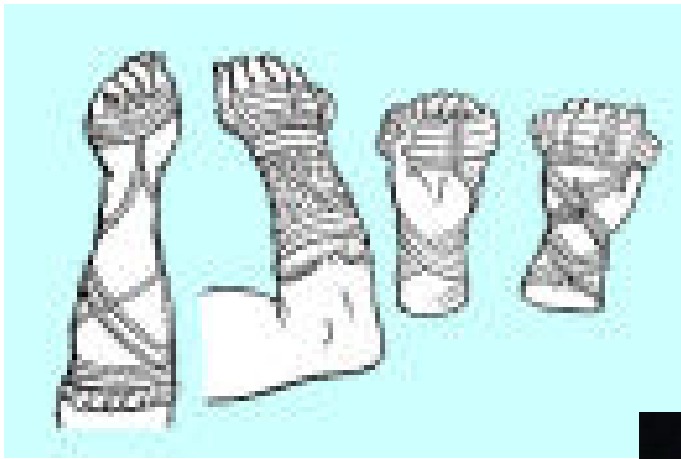

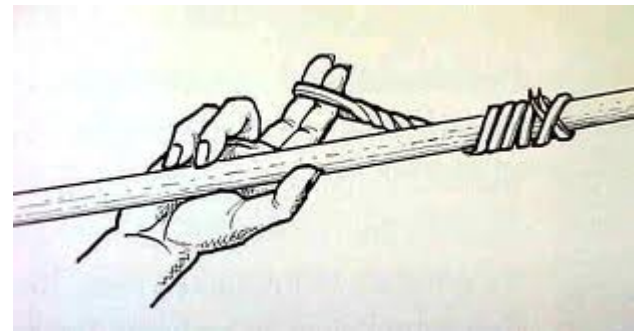

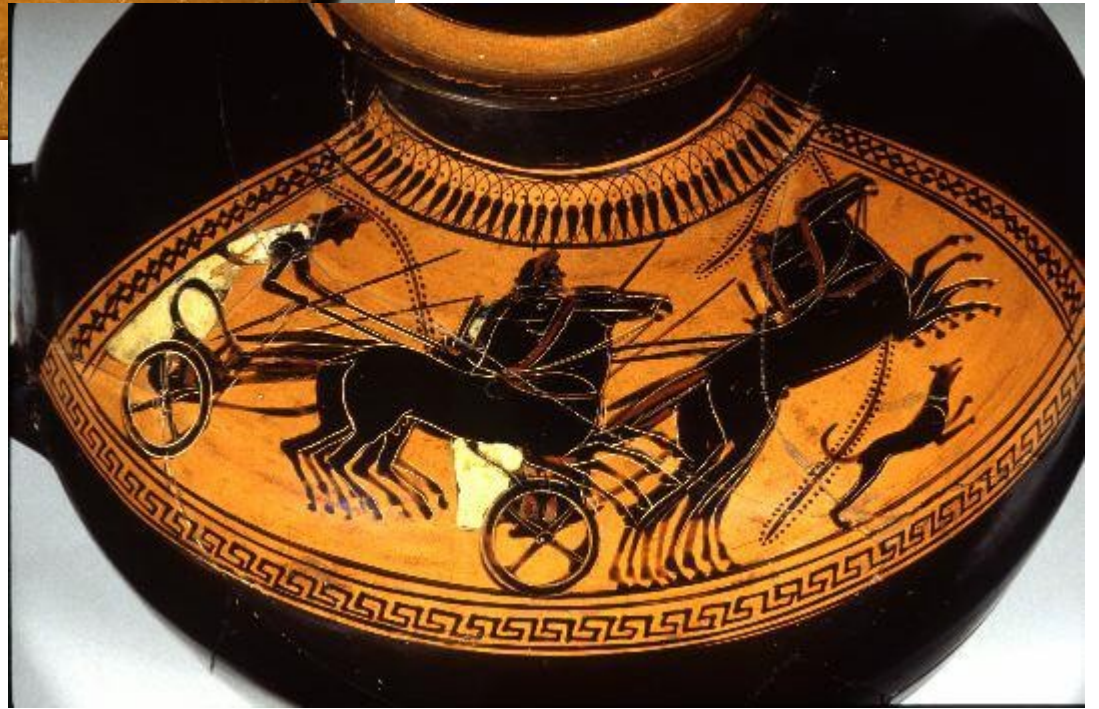

LITERATURA

- ZAMAROVSKÝ, Vojtěch. *Vzkříšení Olympie*. Praha: Olympia, 1980.
- BAHNÍK, Václav. *Slovník antické kultury*. Praha: Svoboda, 1974.
- SVOBODA, Ludvík. *Encyklopedie antiky*. Praha: Academia, 1973.
- NEW PAULY ONLINE, Litterae ante portas