

# Dějiny Řecka I. seminář

## 4. TÉMA OLYMPIE A OLYMPIJSKÉ HRY



### Greece and the Aegean during the Dark Ages (12th – 9th cents. BC); the most important sites

● Important settlement	Chronology:	Finding - places of imported goods:
○ Settlement (with / without architectural finds)	▬ Late Helladic (12th / early 11th cents.)	⊥ Orient
⌂ Necropolis / tomb	▬ Sub - Mycenaean / Sub - Minoan (early - mid 11th cent.)	⊥ Cyprus
⌂ Sanctuary	▬ Proto - geometric (mid 11th cent. – c. 900 BC)	⊥ Italy, Europe
⌂ Centre of pottery production	▬ Geometric (Early, Middle) (9th – early 8th cents.)	Mykenai Ancient name
? ⌂ Identification uncertain	▬ Dating certain / uncertain	Çömlekçi Modern name
		(Rhodos) Island



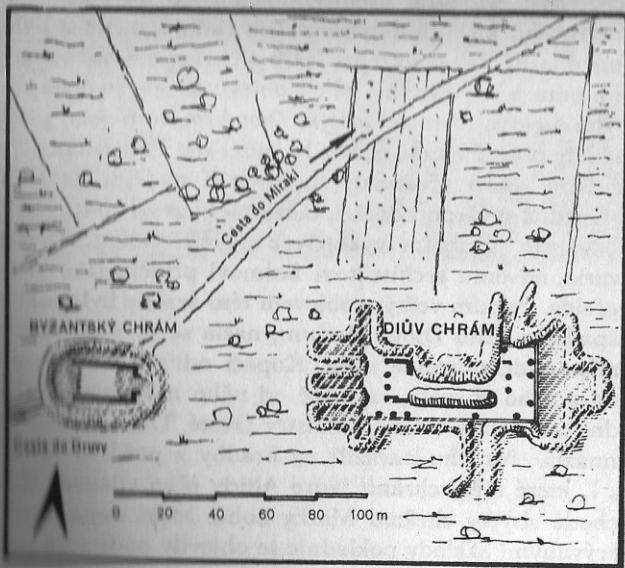

*Vykopávky v Olympii. Vlevo stav po francouzských výkopech roku 1829, vpravo po dvou sezónách německých výkopů roku 1887. Poloha stadiónu a jiných sportovních staveb nebyla tehdy ještě známa*

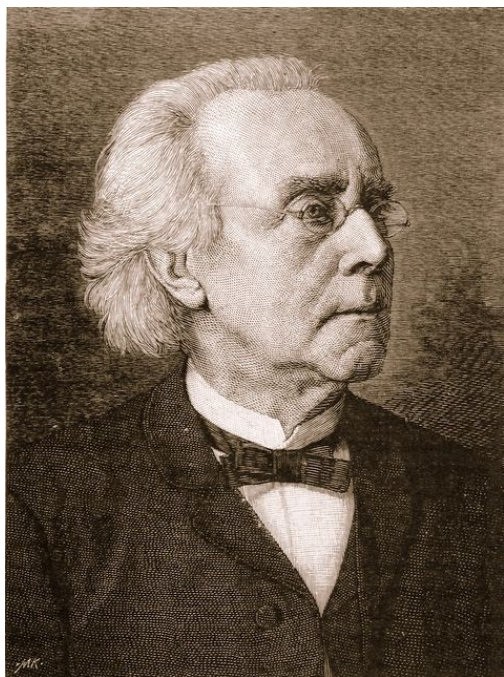
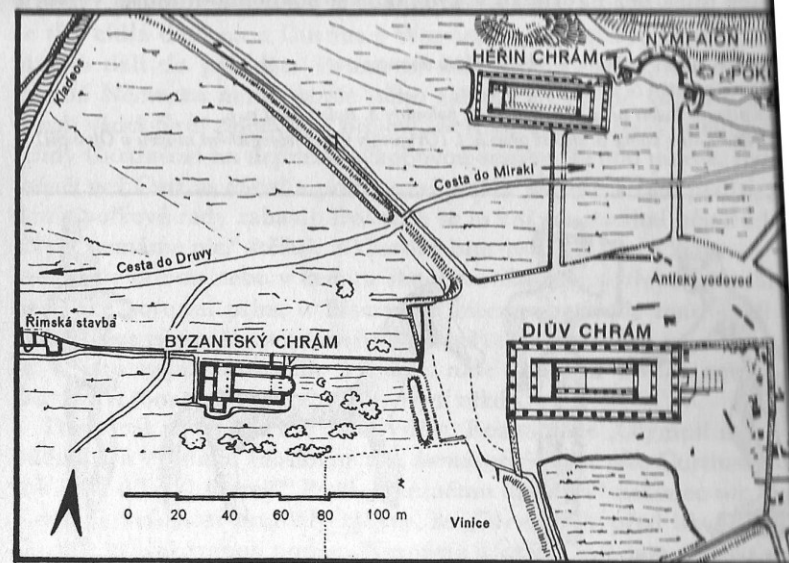

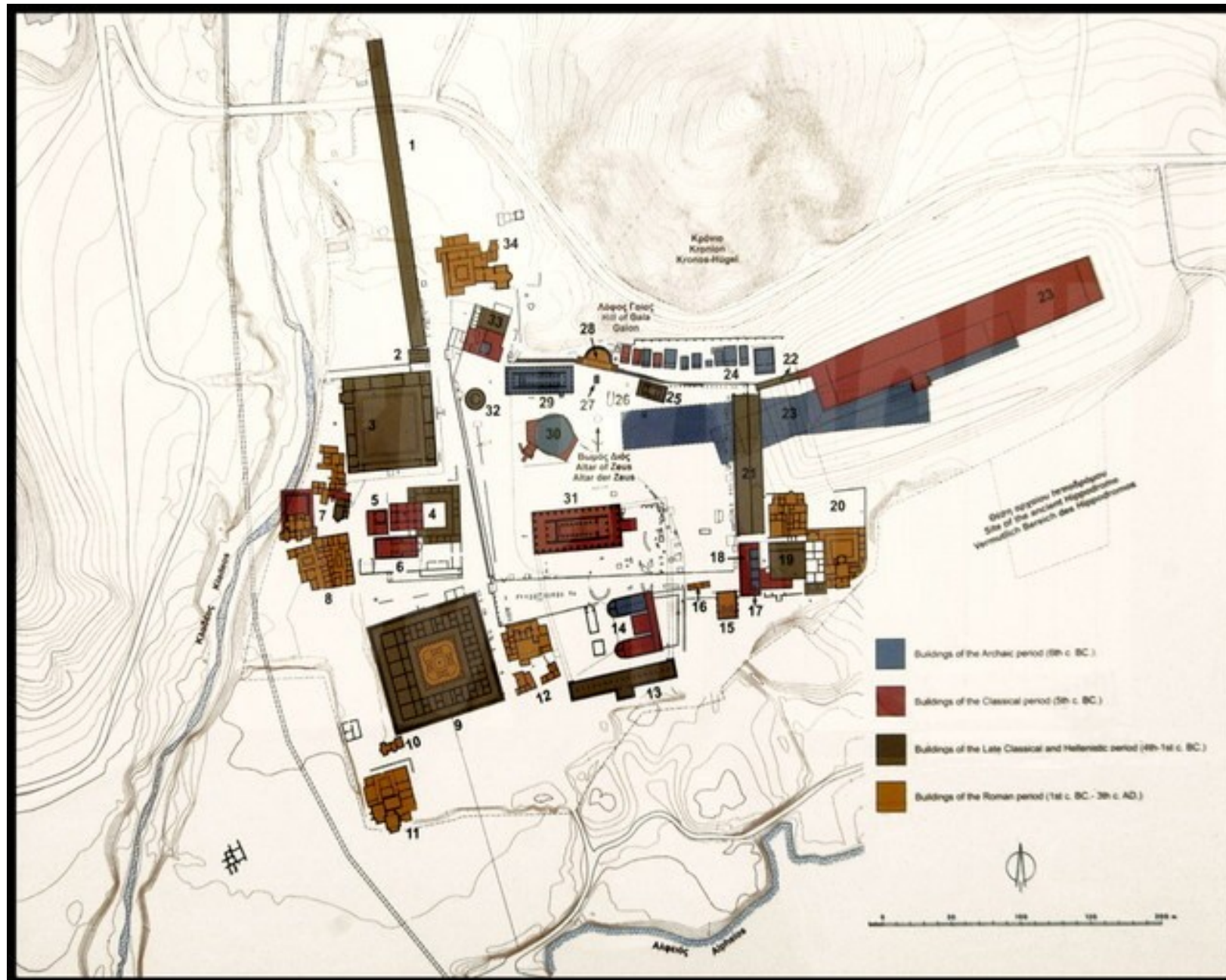

1. Gymnasium
2. Propylon
3. Palaestra
4. Theokleon
5. Heron
6. Pheidias' workshop
7. Kladeos baths
8. Roman Guest Accomodation
9. Leonidion
10. Ἰσμεῖος Ἄλσος
11. SW Baths-Athlet's Club
12. Southern Baths
13. Southern Colonnade
14. Bouleuterion
15. Odeion
16. Arch of Nero
17. Sanctuary of Hestia
18. SE building
18. Greek Building
20. Octagon
21. Echo Colonnade
22. Krypte
23. Stadion
24. Treasuries
25. Metroon
26. Prehistoric apsidal building II
27. Altar of Hera
28. Nymphaion
28. Herain
30. Pelopion
31. Temple of Zeus
32. Philippaion
33. Pnythasion
34. Building of a Roman House



*An aerial view of Olympia, Greece*





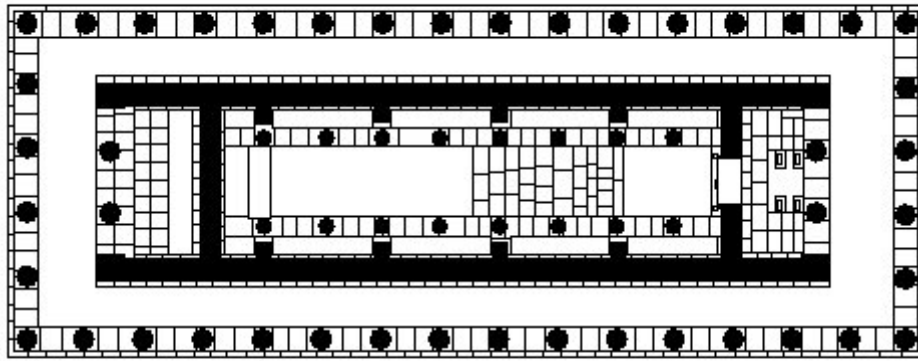

0 1 10 m. ↑



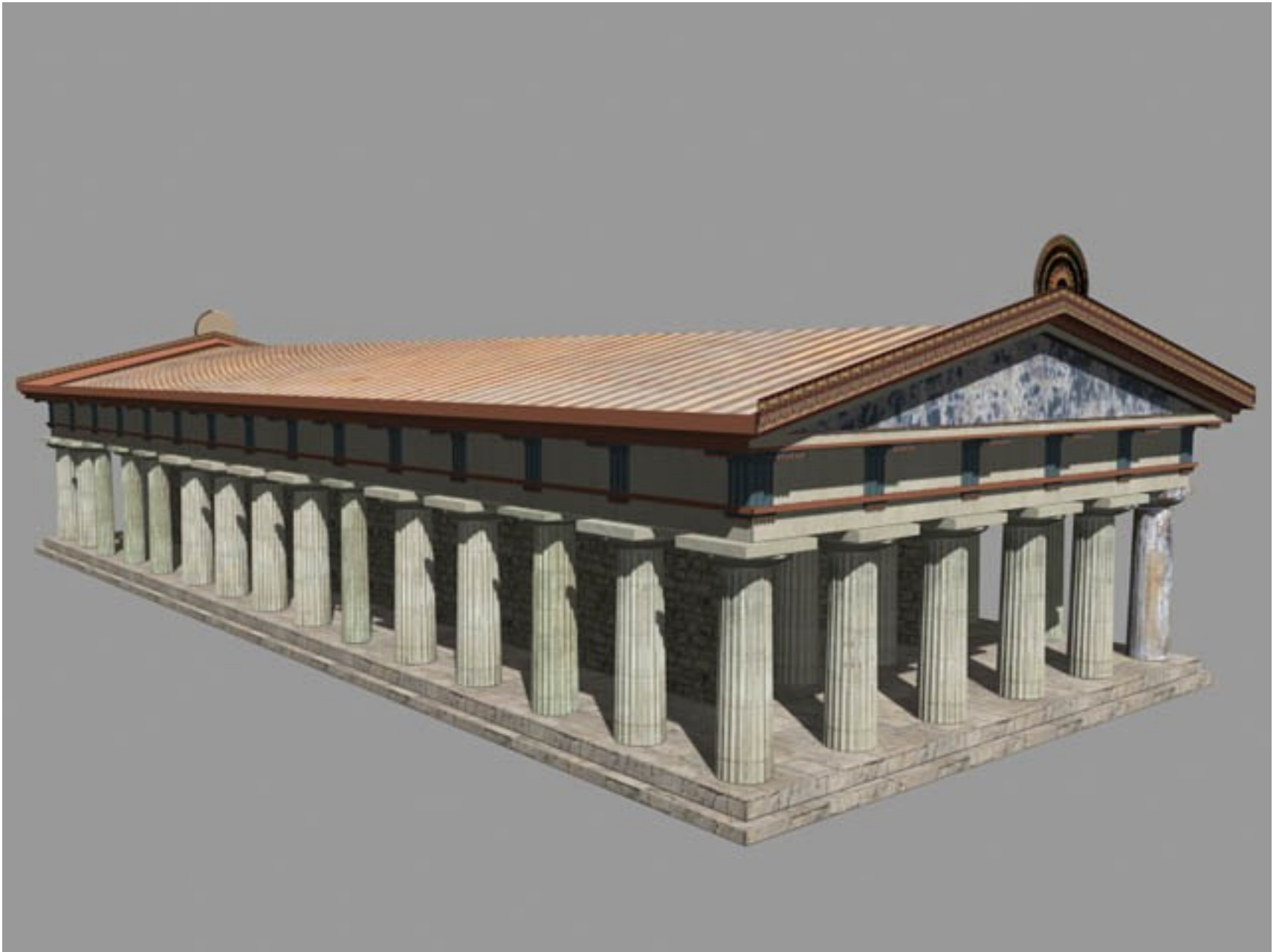





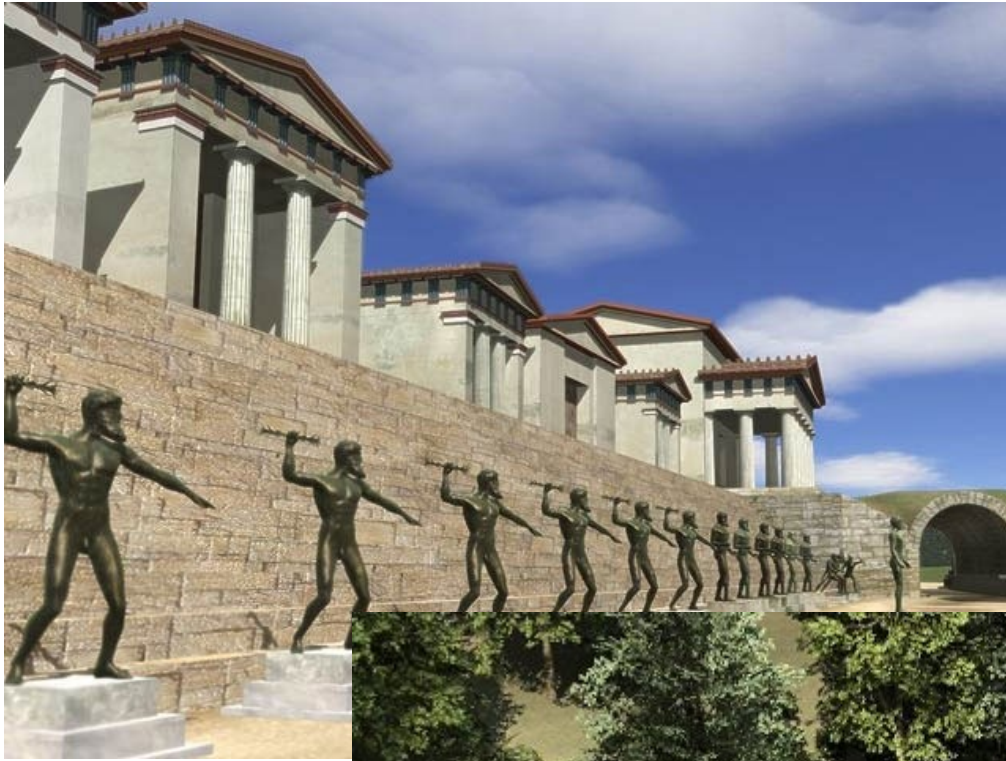

Olympia, Pelopeion

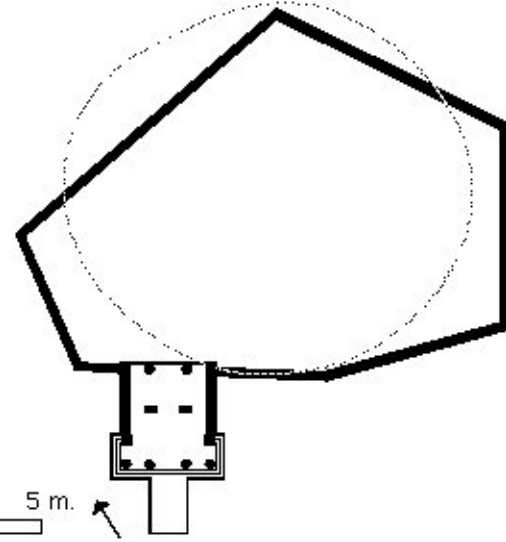
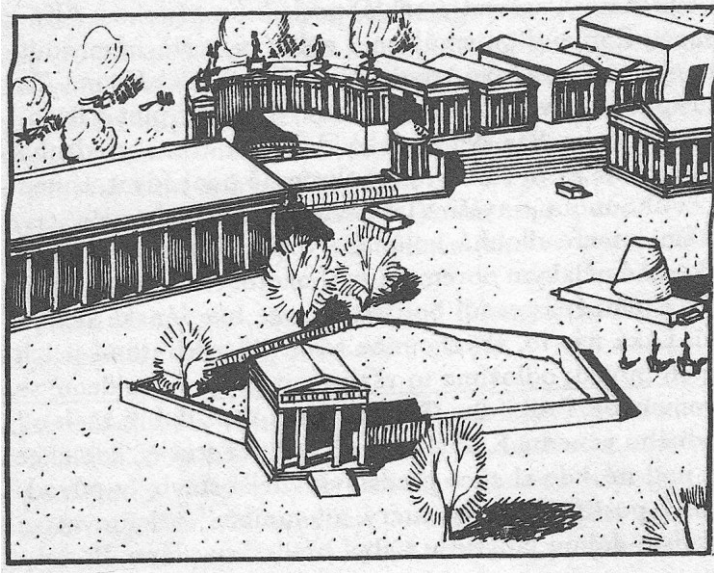



# Olympia, Bouleuterion

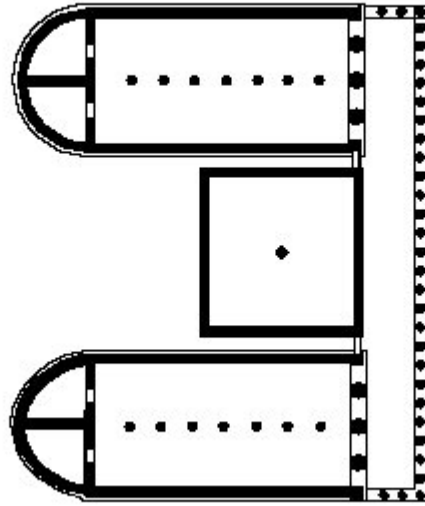

0 10 m.



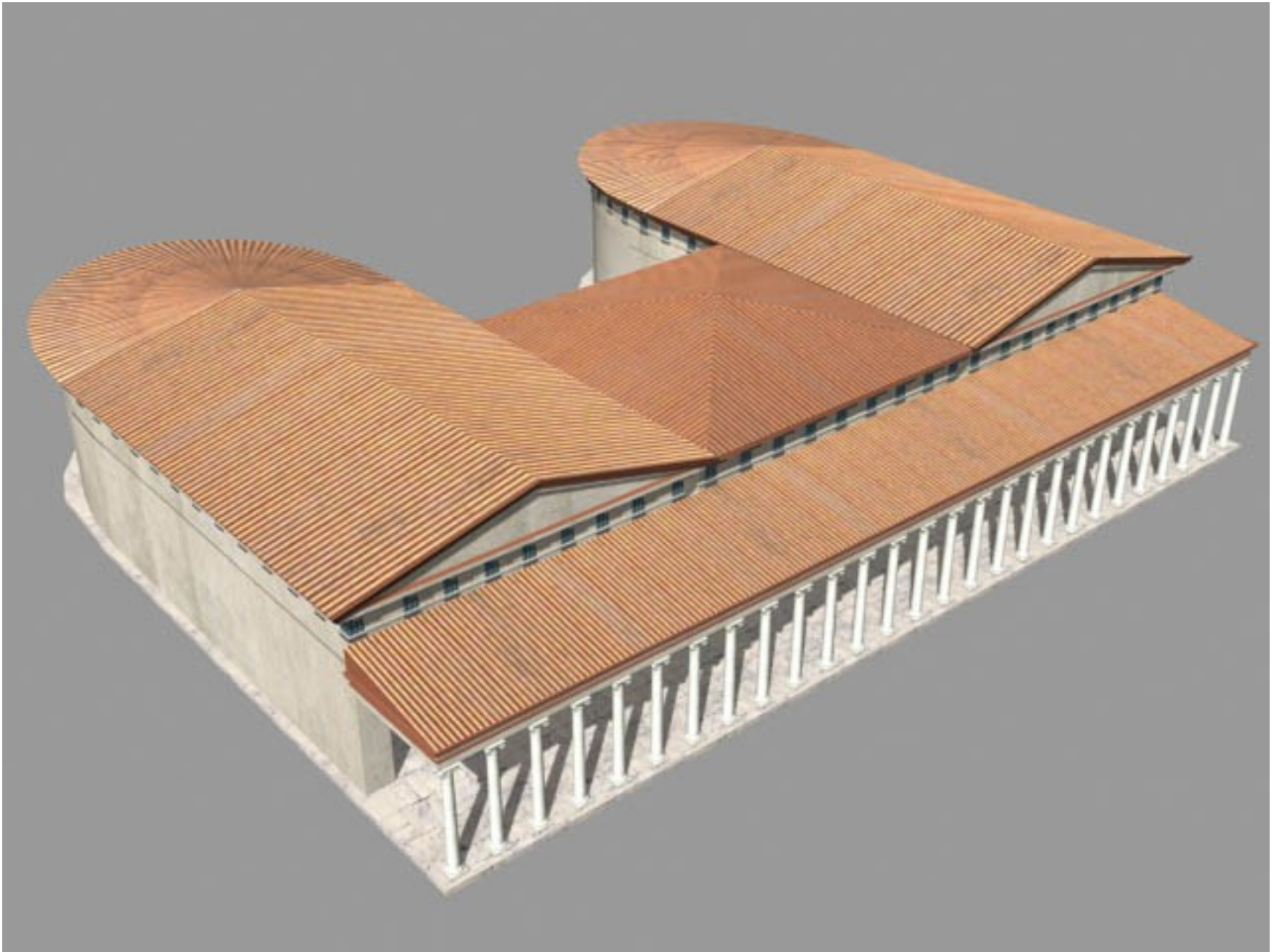

# Olympia, Temple of Zeus

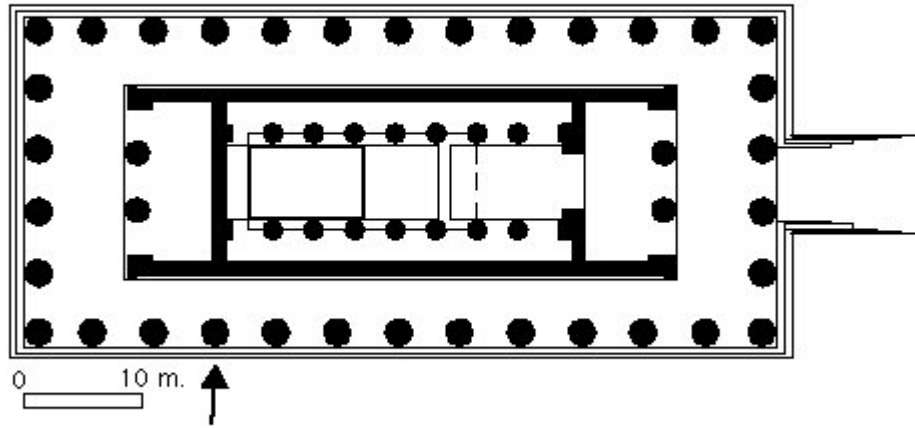







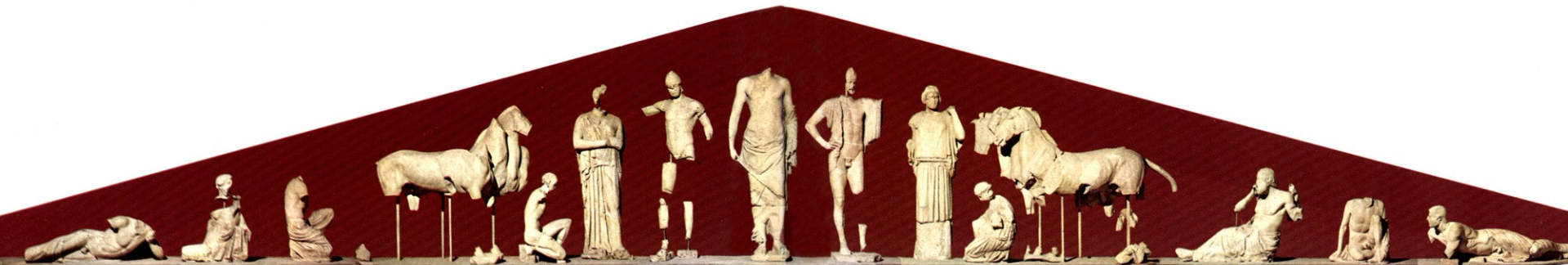

*Alpheios or Kladeos*

*Diviner*

*Charioteer*

*Horses from Oinomaos' or Pelops' chariot*

*Kneeling youth (Myrtilos?)*

*Sterope or Hippodameia*

*Pelops*

*Zeus*

*Oinomaos*

*Hippodameia or Sterope*

*Kneeling girl*

*Horses from Oinomaos' or Pelops' chariot*

*Old diviner (Iamos?)*

*Crouching youth (possibly Arkas)*

*Kladeos or Alpheios*





*Lapith woman   Old Lapith woman   Lapith   Centaur   Lapith woman   Centaur and Lapith   Theseus   Centaur   Lapith woman   Apollo   Deidameia and Centaur Eurytion   Peirithoos   Lapith and Centaur   Lapith woman and Centaur   Lapith   Old Lapith woman   Lapith woman*

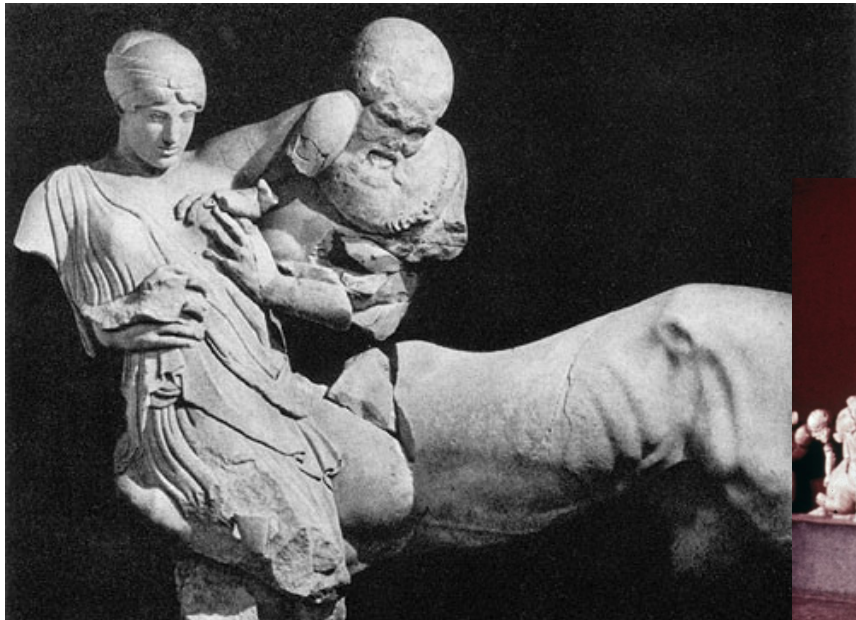

Athena

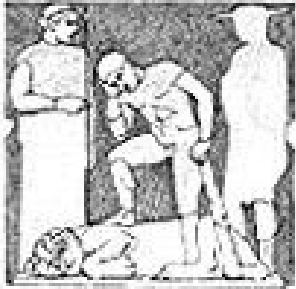

Athena

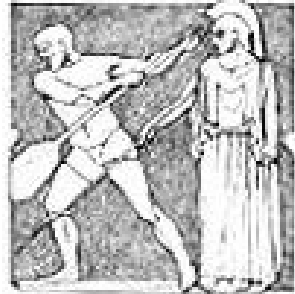
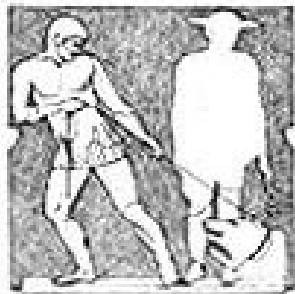
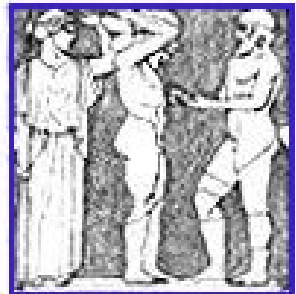
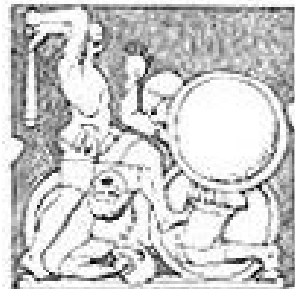
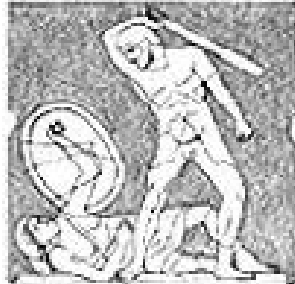
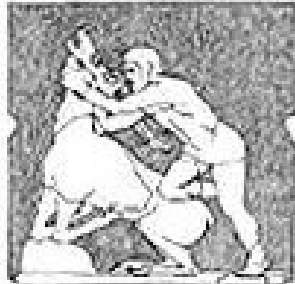
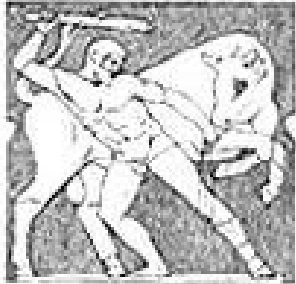
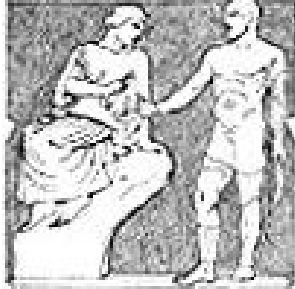

Athena

Athena



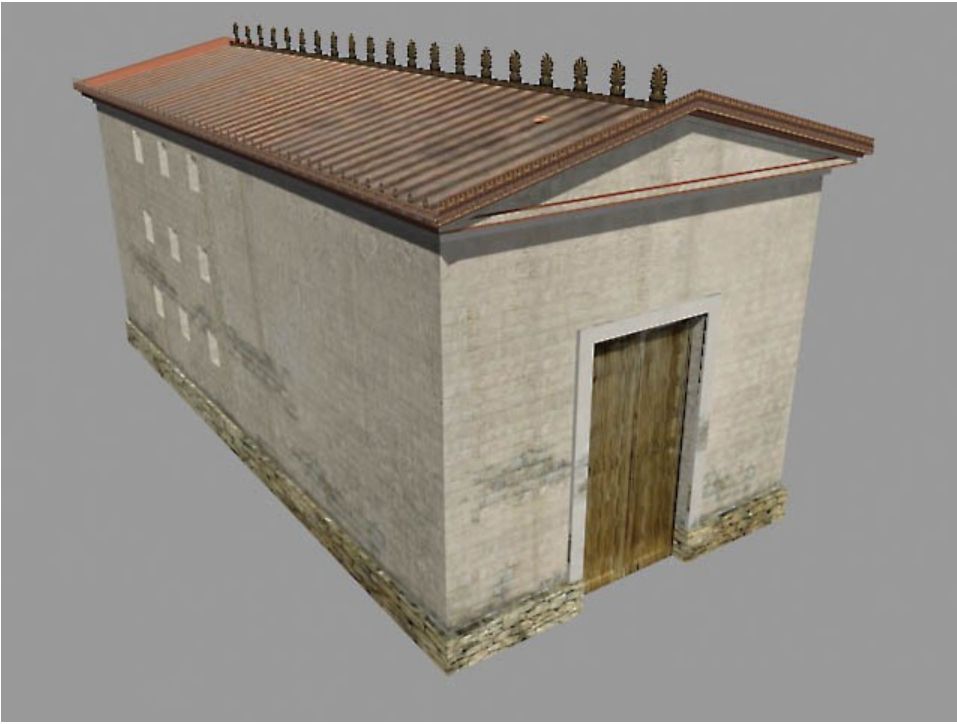



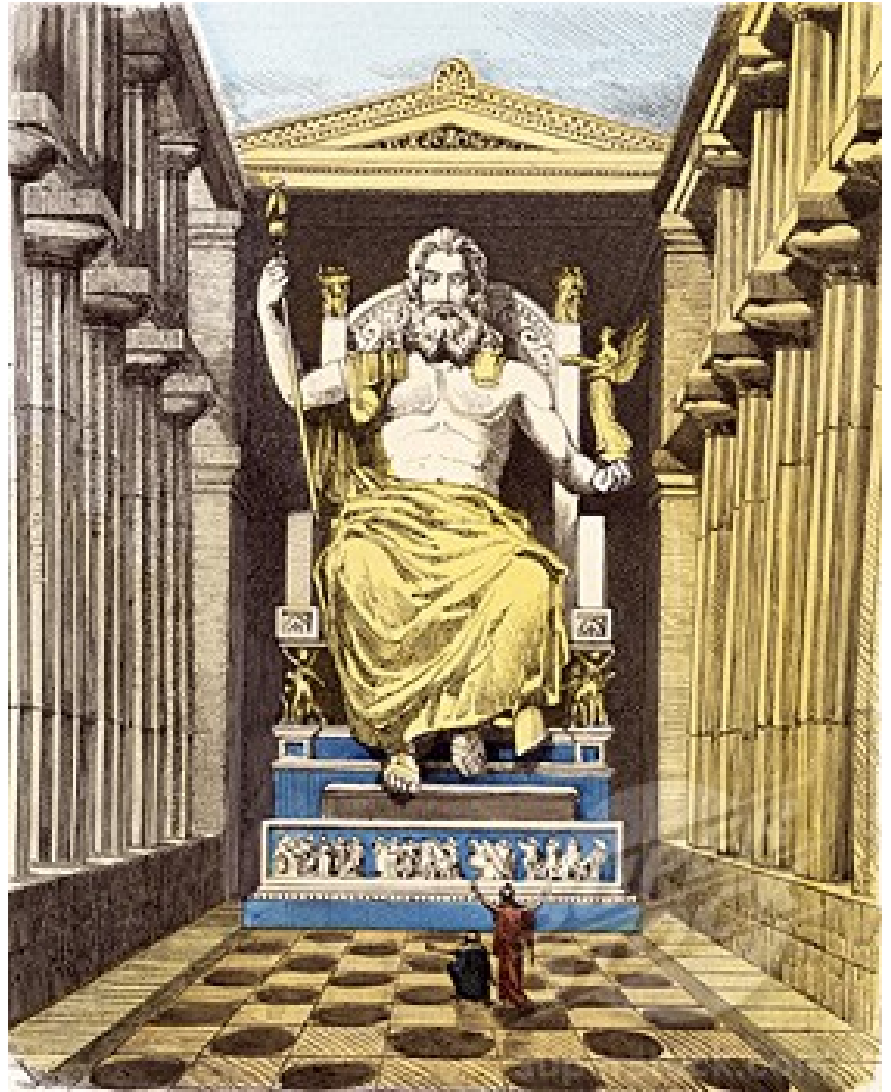



Olympia, Metroon

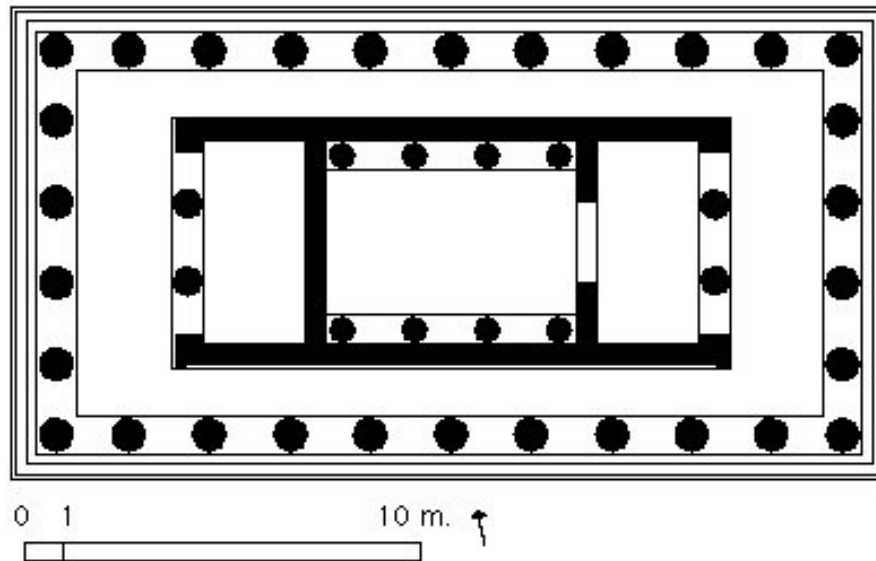





π

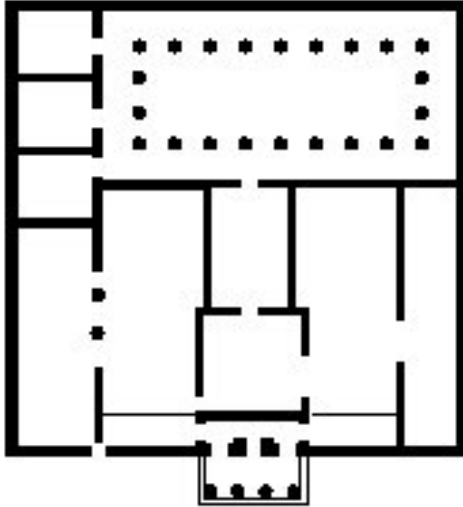

0 10 m.



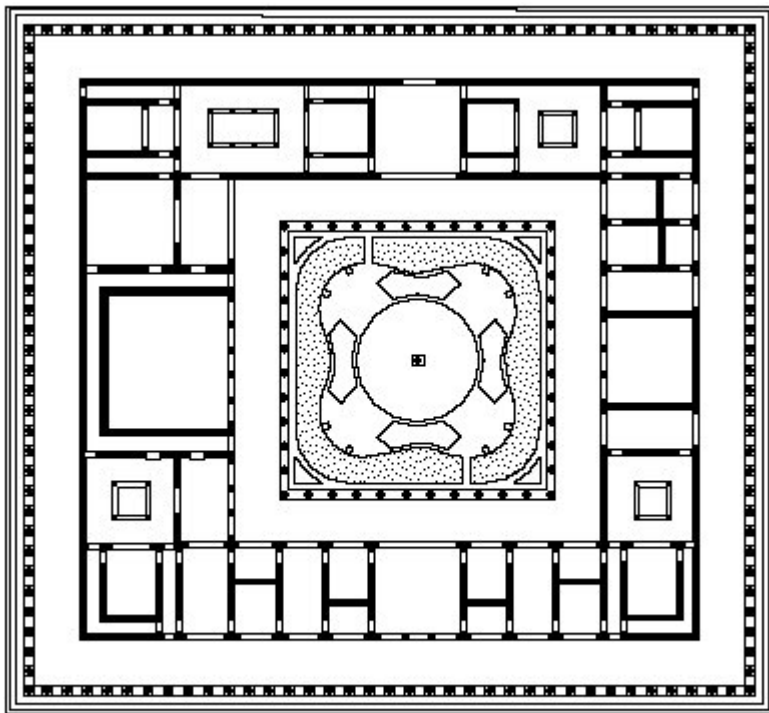

0 20 m



# Olympia, Echohall (Painted Stoa)

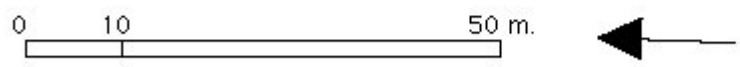
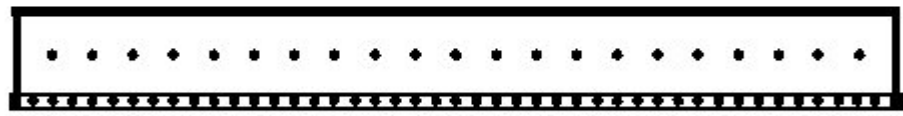

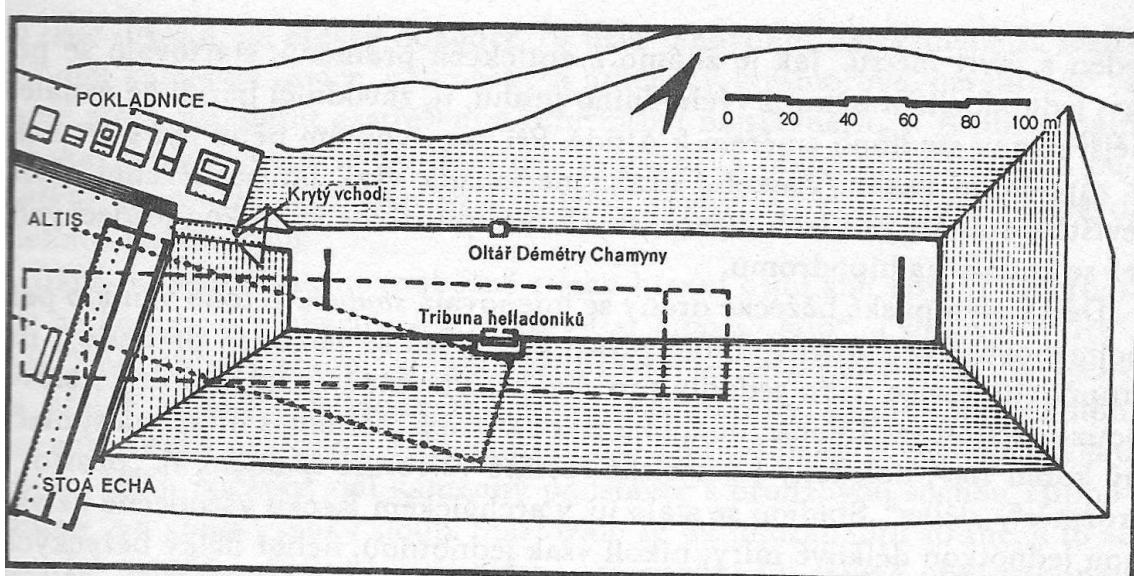

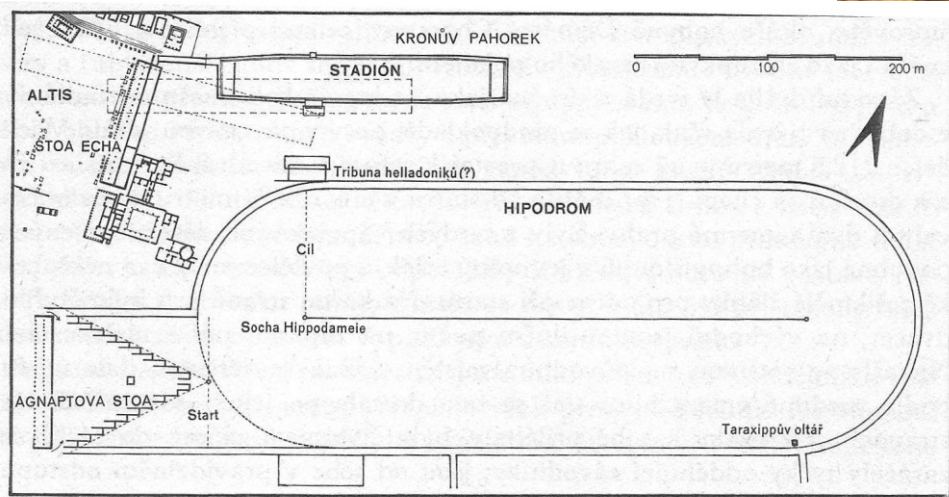
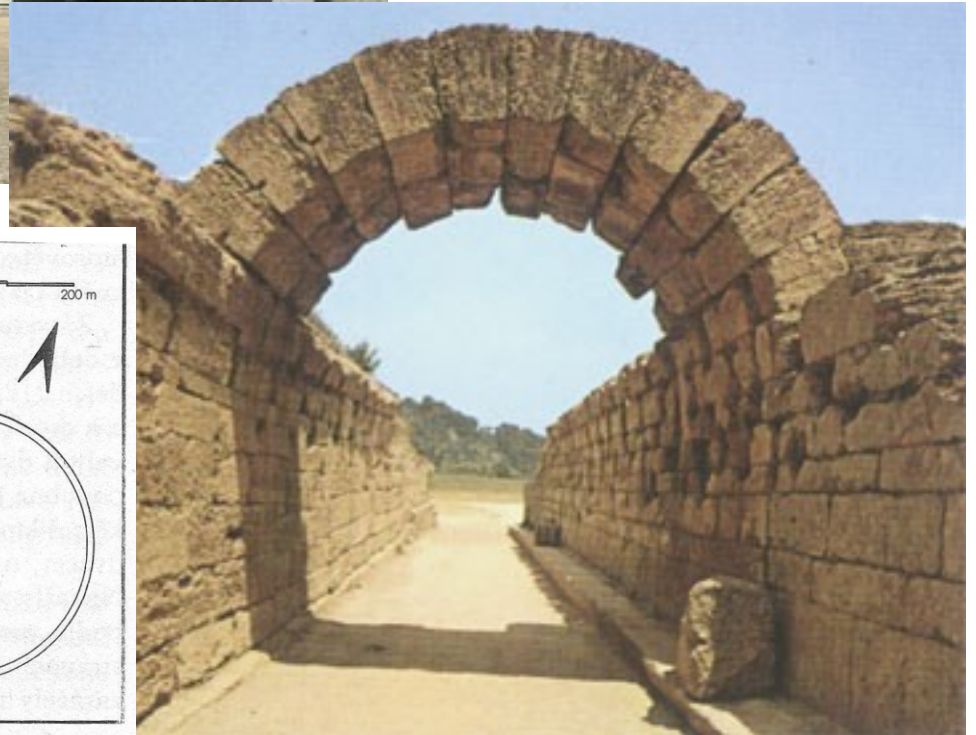

Olympia, Philippeion

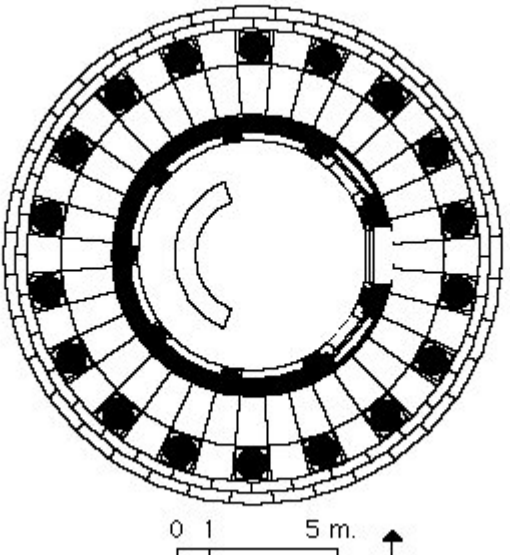

Olympia, Palaestra

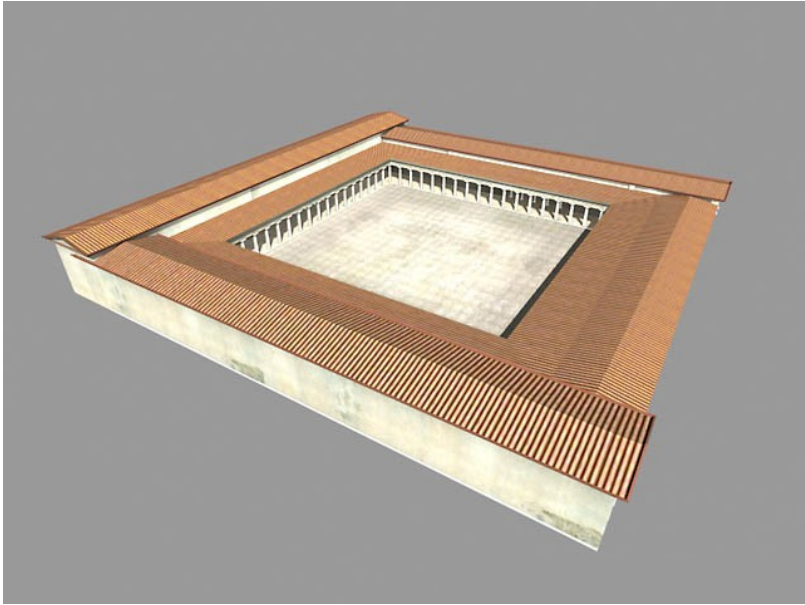
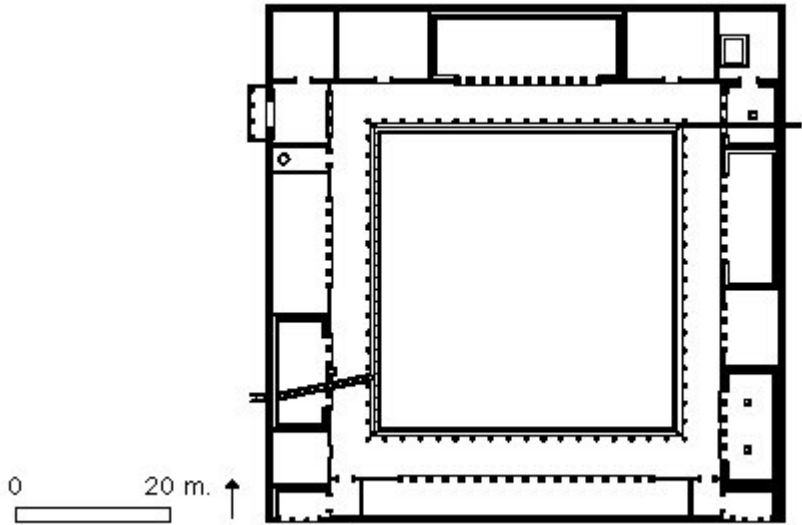



# Olympia, Gymnasium

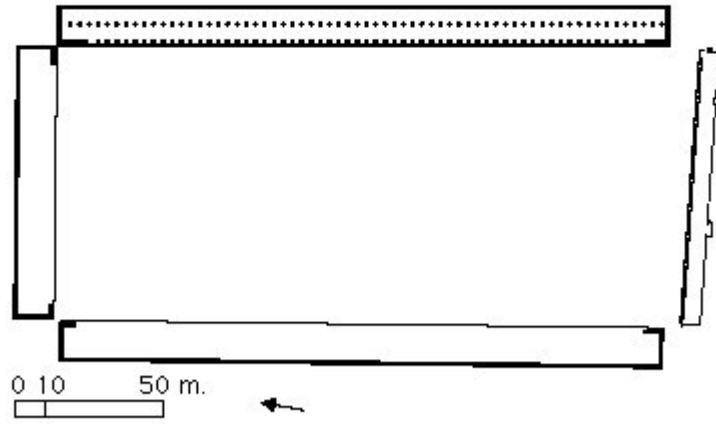

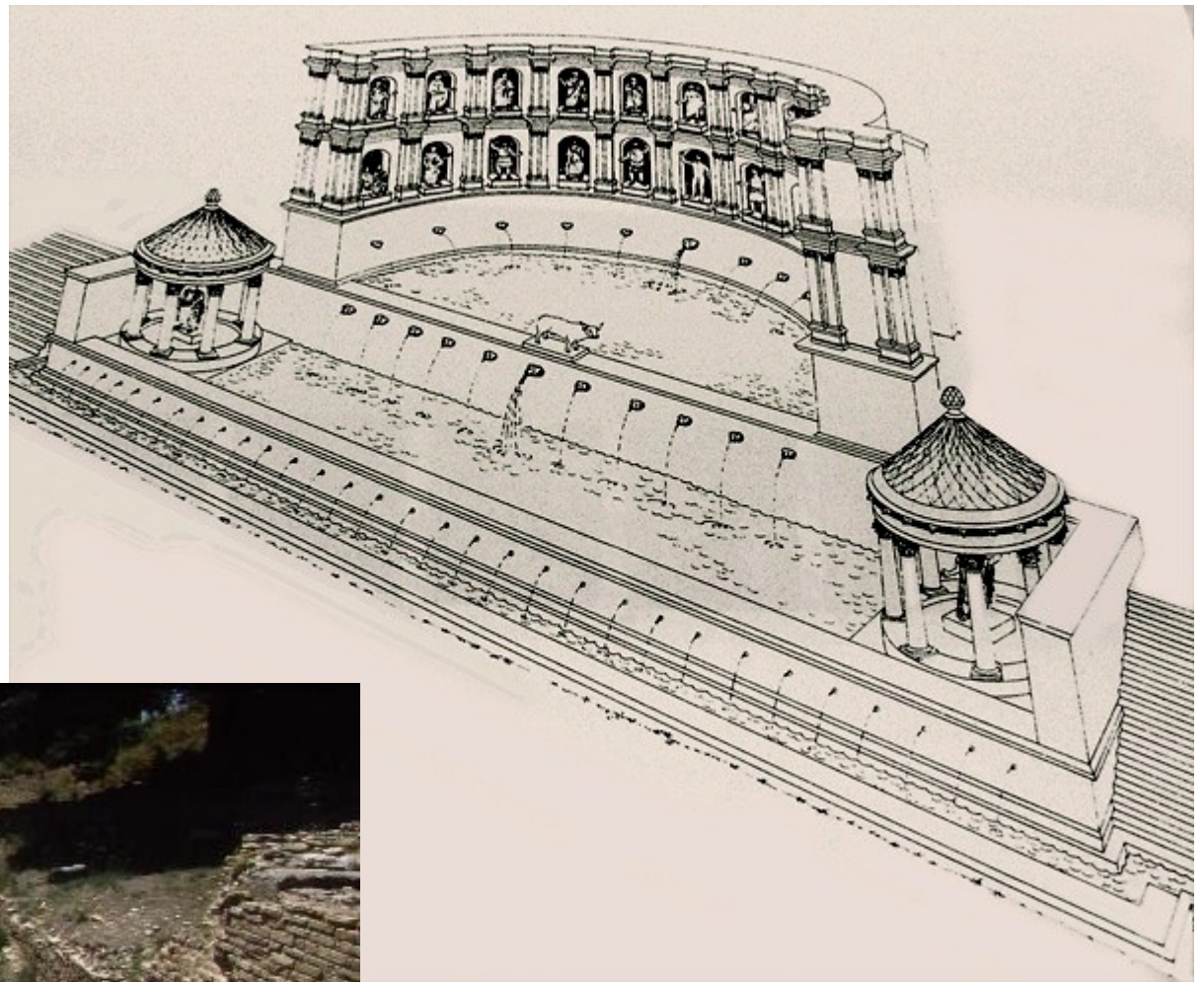



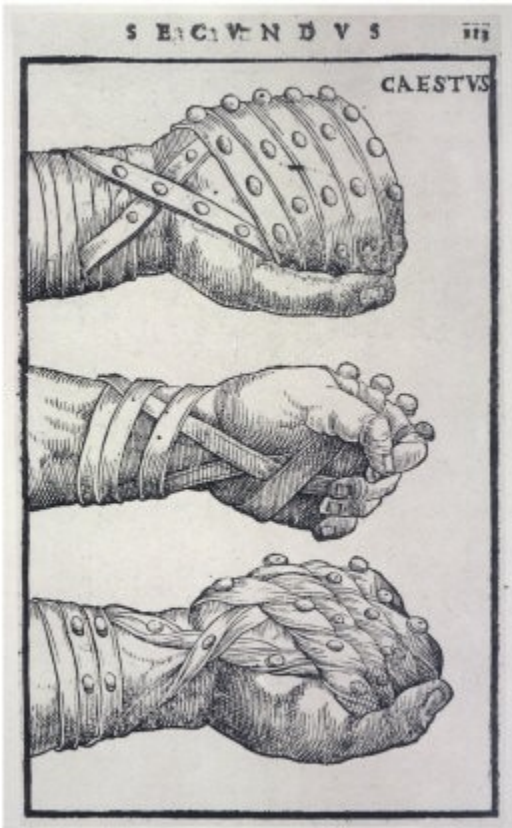
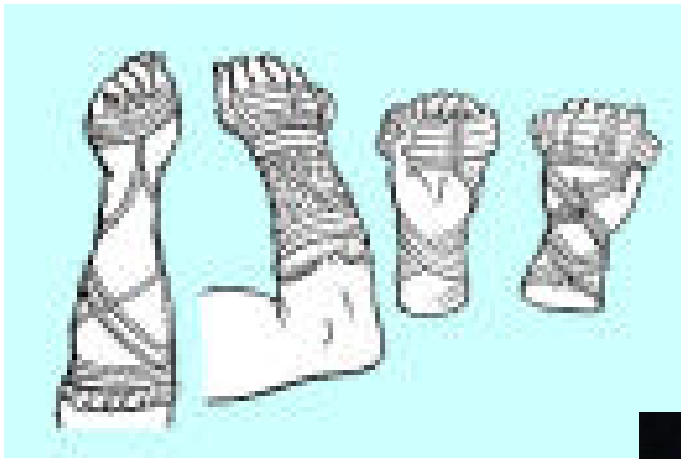

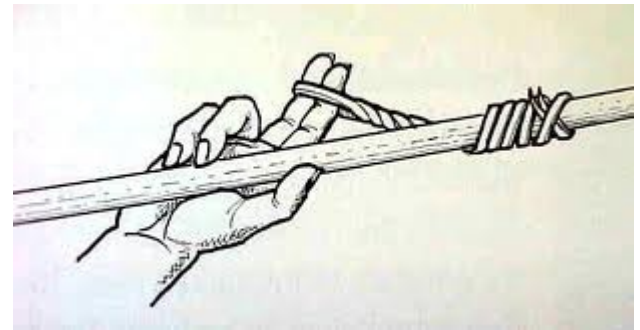

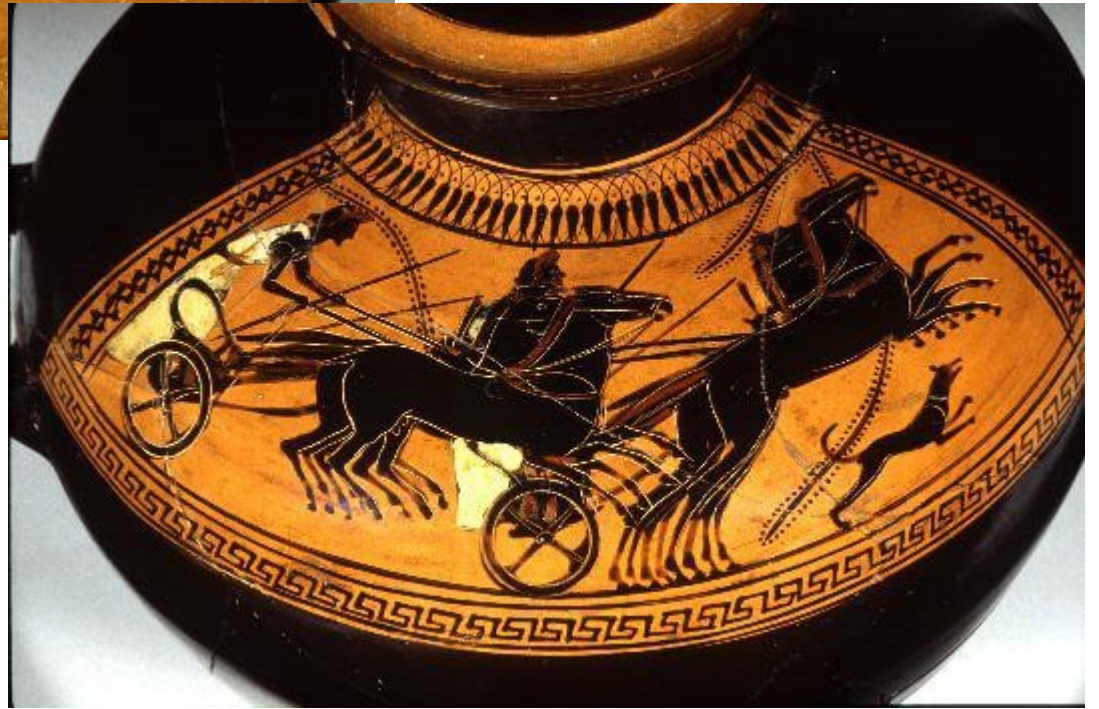
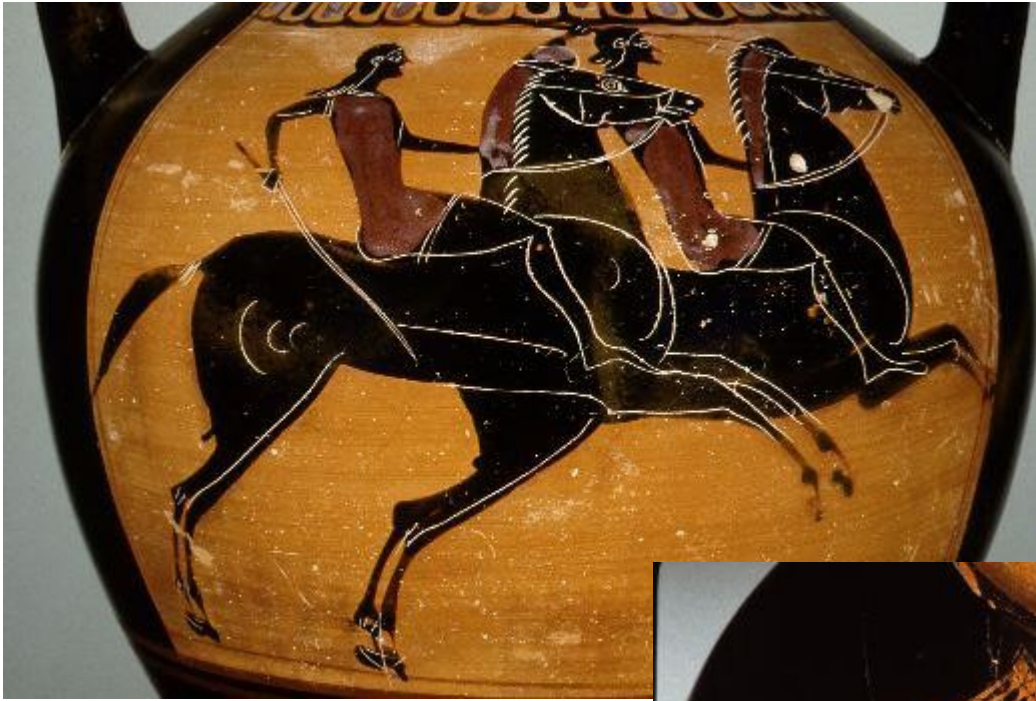

# LITERATURA

- ZAMAROVSKÝ, Vojtěch. *Vzkříšení Olympie*. Praha: Olympia, 1980.
- BAHNÍK, Václav. *Slovník antické kultury*. Praha: Svoboda, 1974.
- SVOBODA, Ludvík. *Encyklopedie antiky*. Praha: Academia, 1973.
- NEW PAULY ONLINE, Litterae ante portas