

Zvuk



I am the Edison Phonograph (1906)





*Bruce, syn misionáře,
žije radostným
a bezstarostným životem
dětství.....*

Universal

*Bruce, syn misionáře,
žije radostným
a bezstarostným životem
dětství.....*

Universal

Akustické přístroje

Fonograf (Edison) a Gramofon (Berliner)



Audion - Lee de Forest

1906



1908

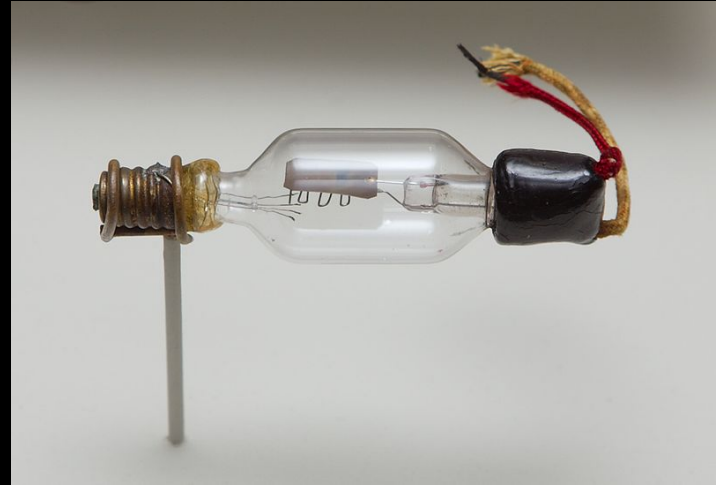

1926

- Vitaphone
- Movietone
- RCA Photophone
- Western Electric

Experimentování a standardizace

NÁSTUP SYNCHRONNÍHO ZVUKU

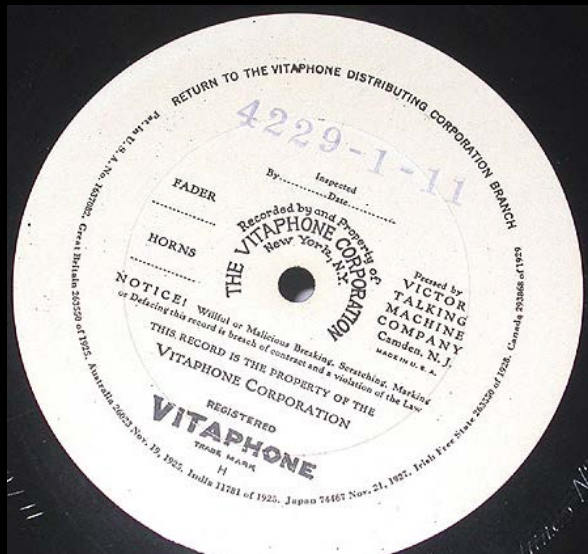
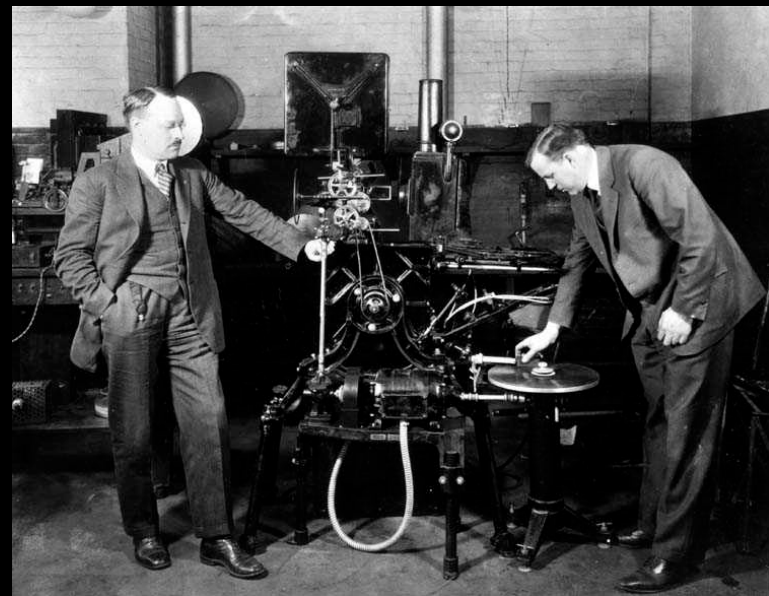

Optický záznam zvuku

Reprodukce optického záznamu
zvuku:

1. lampa budiče; 2. zaostření
světla; 3. zvuková stopa; 4.
fotobuňka; 5. zesilovač; 6.
reproduktor.

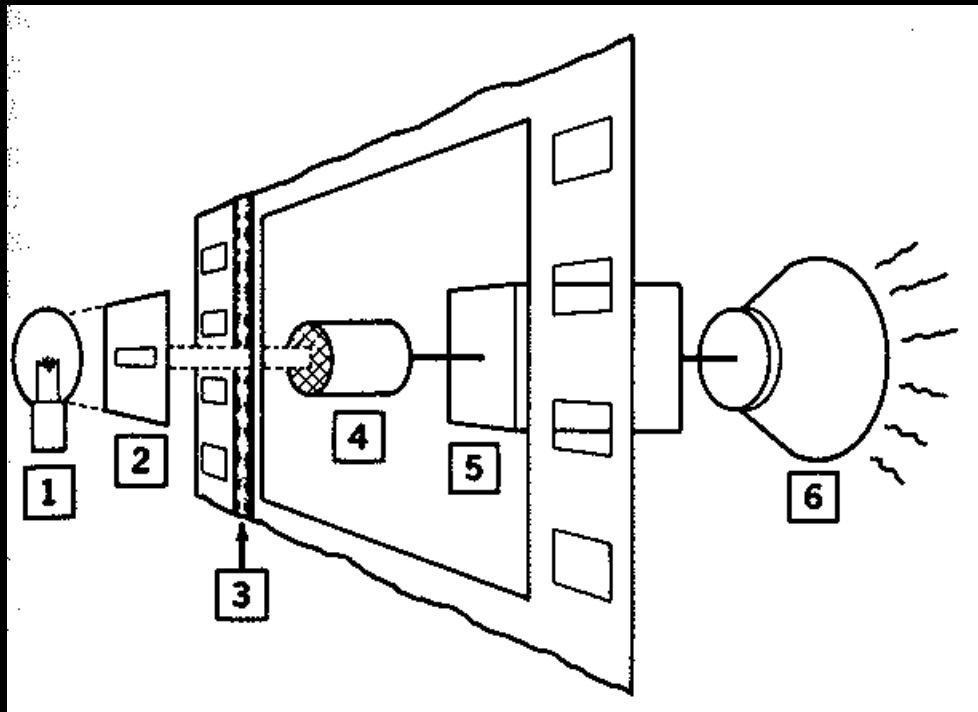

Phonofilm

- VARIABLE
DENSITY –
metoda
intenzivnosti



Phonofilm (Lee de Forest), 1923

VARIABLE AREA - transversální metoda

RCA A RKO

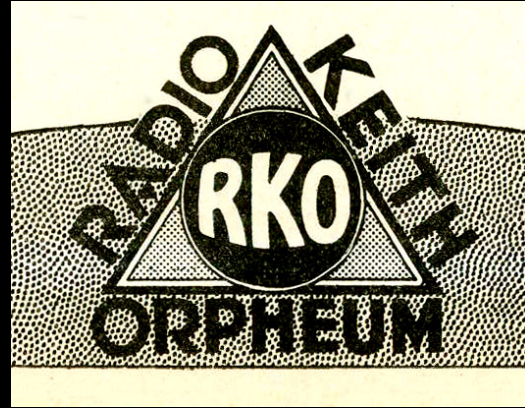

Transversální metoda (variable area)

Metoda intenzivnosti (variable density)

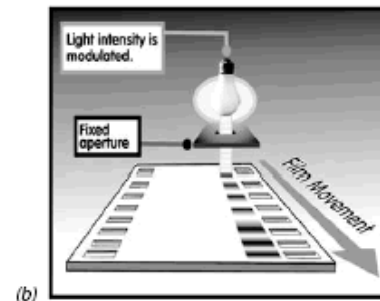
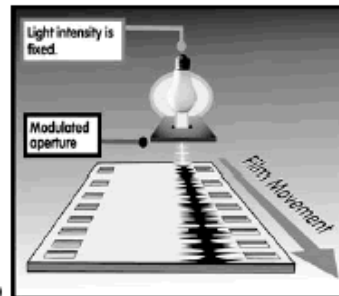
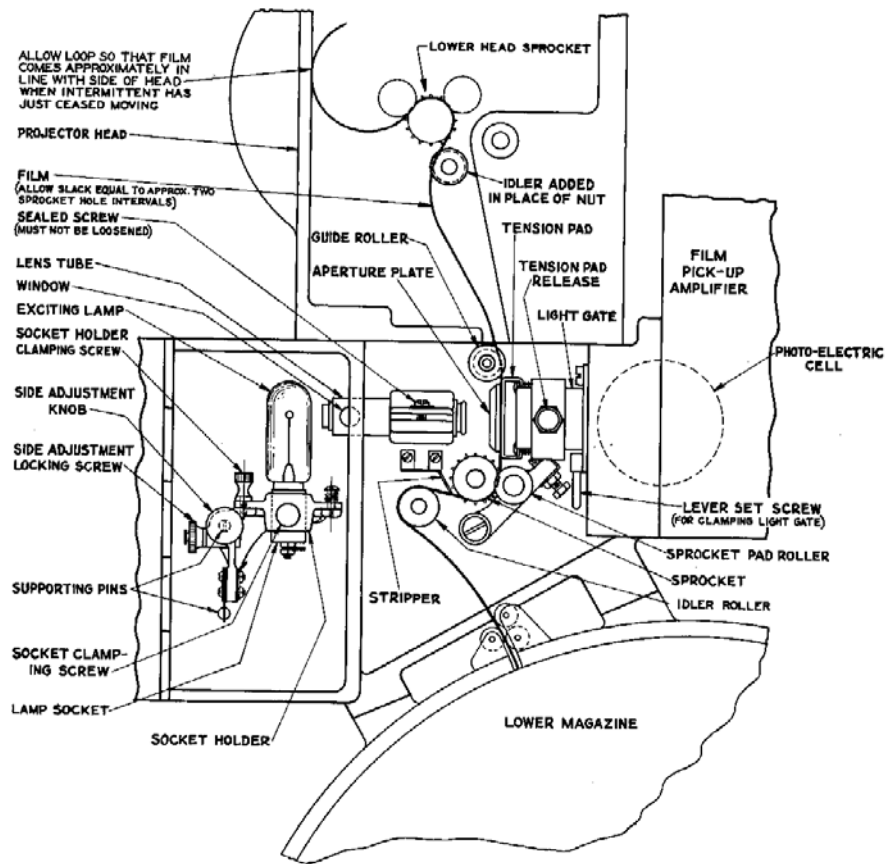

Figure 1: (a) Variable area (b) Variable density

Western Electric





**FILM PICK-UP ATTACHMENT
ON SIMPLEX PROJECTOR**
WESTERN ELECTRIC SOUND PROJECTOR SYSTEMS
ELECTRICAL RESEARCH PRODUCTS INC.

Paříž, 22. července 1930



Synchronní zvuk a Hollywood



„Blimp“

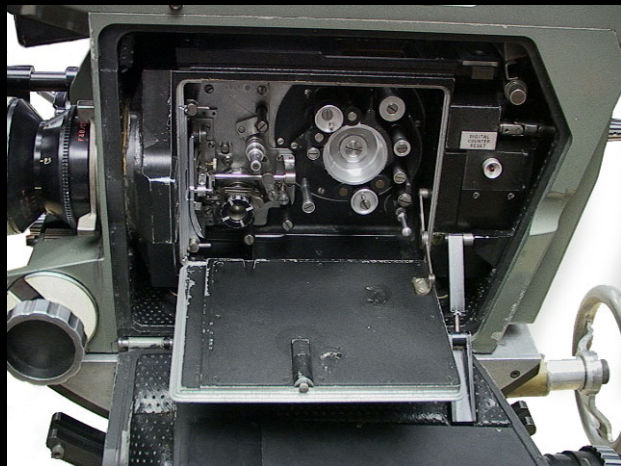

Magnetický záznam zvuku

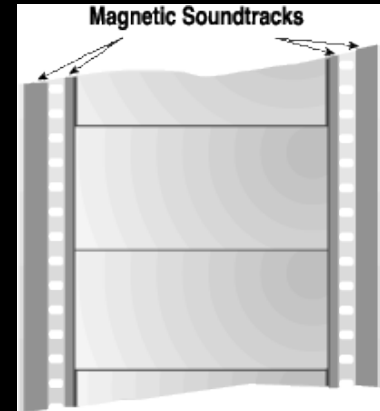

Stereo

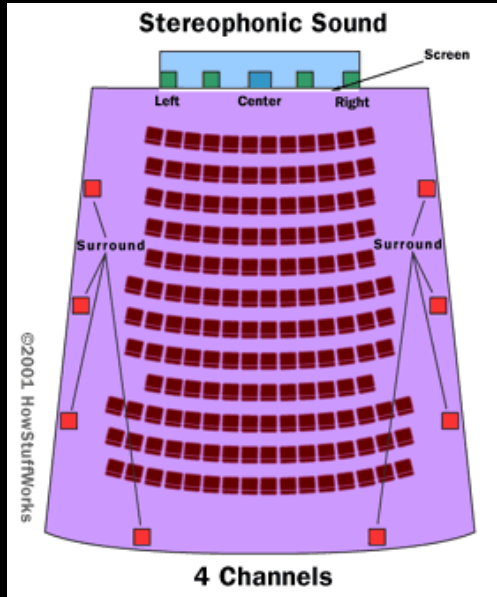

INTRODUCTION TO



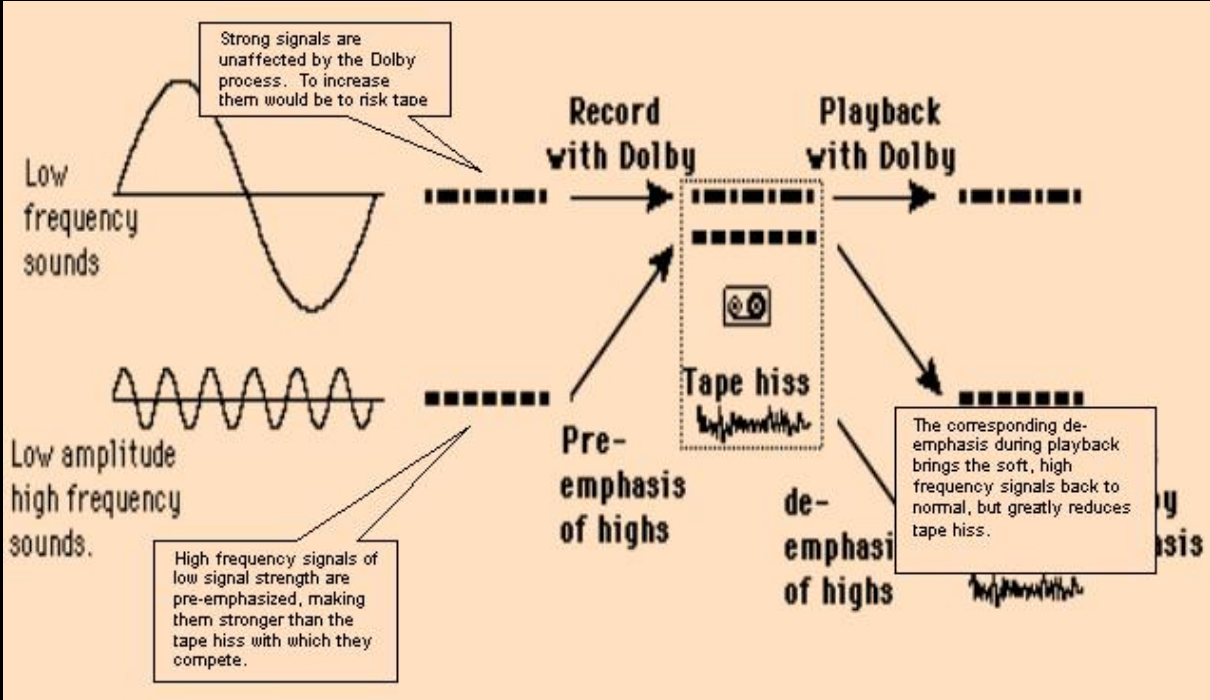

DTS – synchronizace
se soundtrackem na
CD

Analogová
zvuková stopa

Dolby
Digital

SDDS

