

Metody studia Wnt signalizace

Vítězslav BRYJA

Ústav experimentální biologie, PŘF MU
&
Oddělení cytokinetiky, Biofyzikální ústav AV ČR



Zebrafish.mov

Wnts (Wingless/Int)

- family of ligands
- 19 members in human and mouse
- glycosylated and palmitoylated extracellular proteins
- short range of action, bind to extracellular matrix
- only in multicellular animals

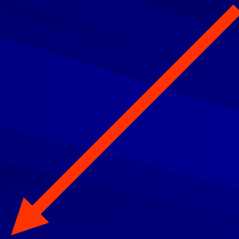

canonical

(eg. Wnt-1 or Wnt-3a)

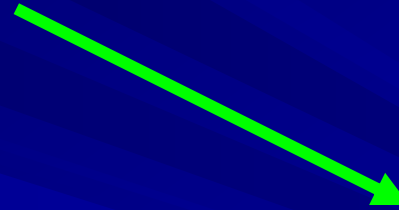

non-canonical

(eg. Wnt-5a)

Canonical Wnt signalling

- eg. Wnt-1 or Wnt-3a



- induce axis duplication in *Xenopus*
- induce transformation of mammary cell line C57mg
- signals via nuclear translocation of β -catenin

Canonical Wnt signalling and tumours

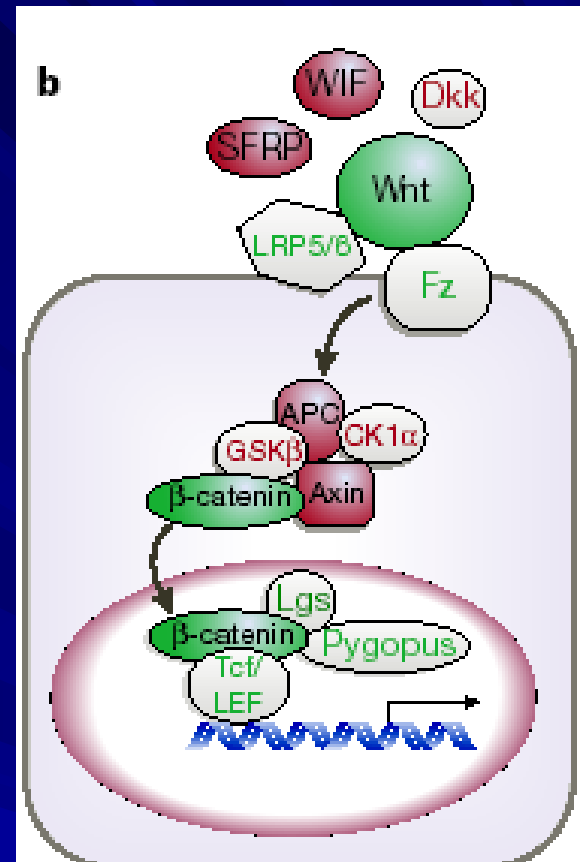

according to Beachy et al., Nature 2004

Wnt pathway

Colon	Adenocarcinoma	Tumorigenesis by inactivation of APC, Axin; tumorigenesis by stabilization of β-catenin; epigenetic inactivation of SFRPs
Liver	Hepatoblastoma	Tumorigenesis (in mouse) by inactivation of APC and by stabilization of β-catenin
Blood	Multiple myeloma	Cell-growth inhibition by dominant negative TCF4; growth stimulation by Wnt ligand
Hair follicle	Pilomatricoma	Tumorigenesis (in mouse) by overexpression of β-catenin
Bone	Osteosarcoma	Dkk3 and LRP5 expression inhibits tumour cell growth <i>in vitro</i>
Lung	Non-small-cell carcinoma	Apoptosis and cell-growth inhibition by short interfering RNA and a blocking antibody against Wnt2
Pleura	Mesothelioma	Apoptosis and cell-growth inhibition by transfection of SFRP

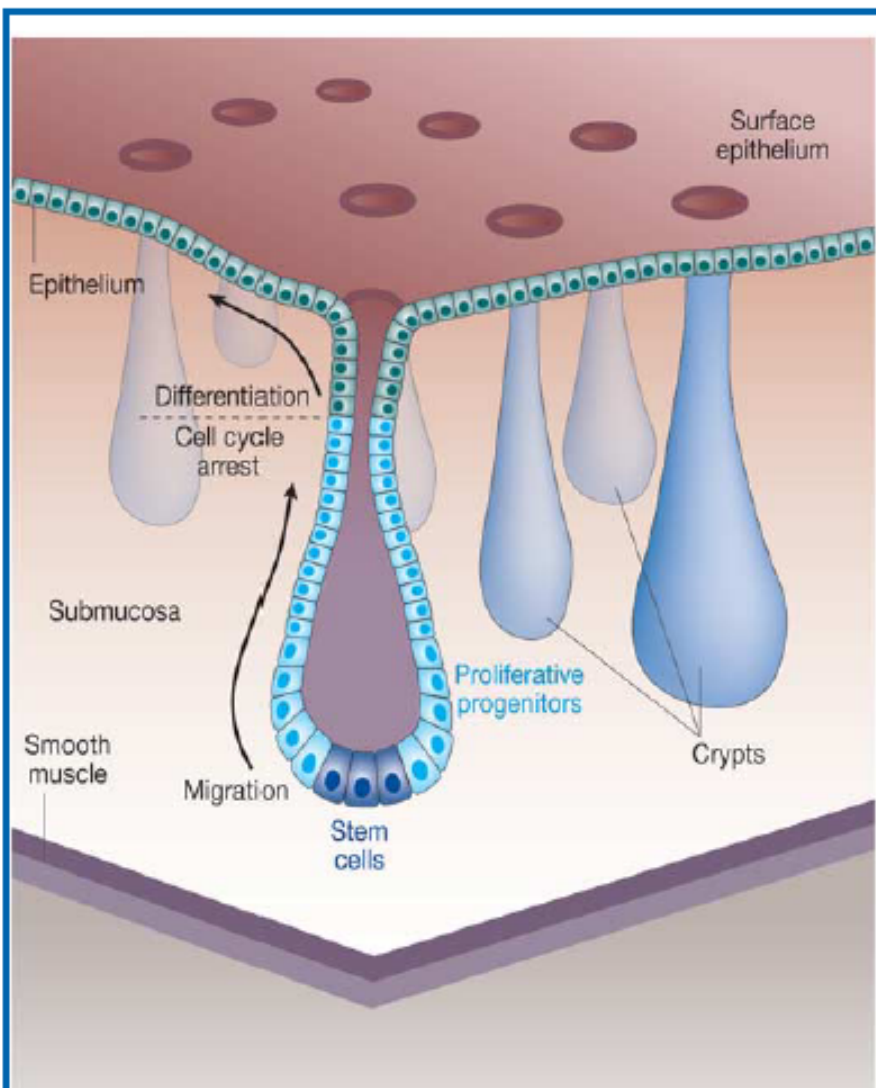

Figure 3 Tissue anatomy of the colonic epithelium. Putative stem cells (dark blue) reside at the crypt bottom. Proliferating progenitor cells occupy two-thirds of the crypt. Differentiated cells (green) populate the remainder of the crypt and the flat surface epithelium. (Adapted from ref. 89.)

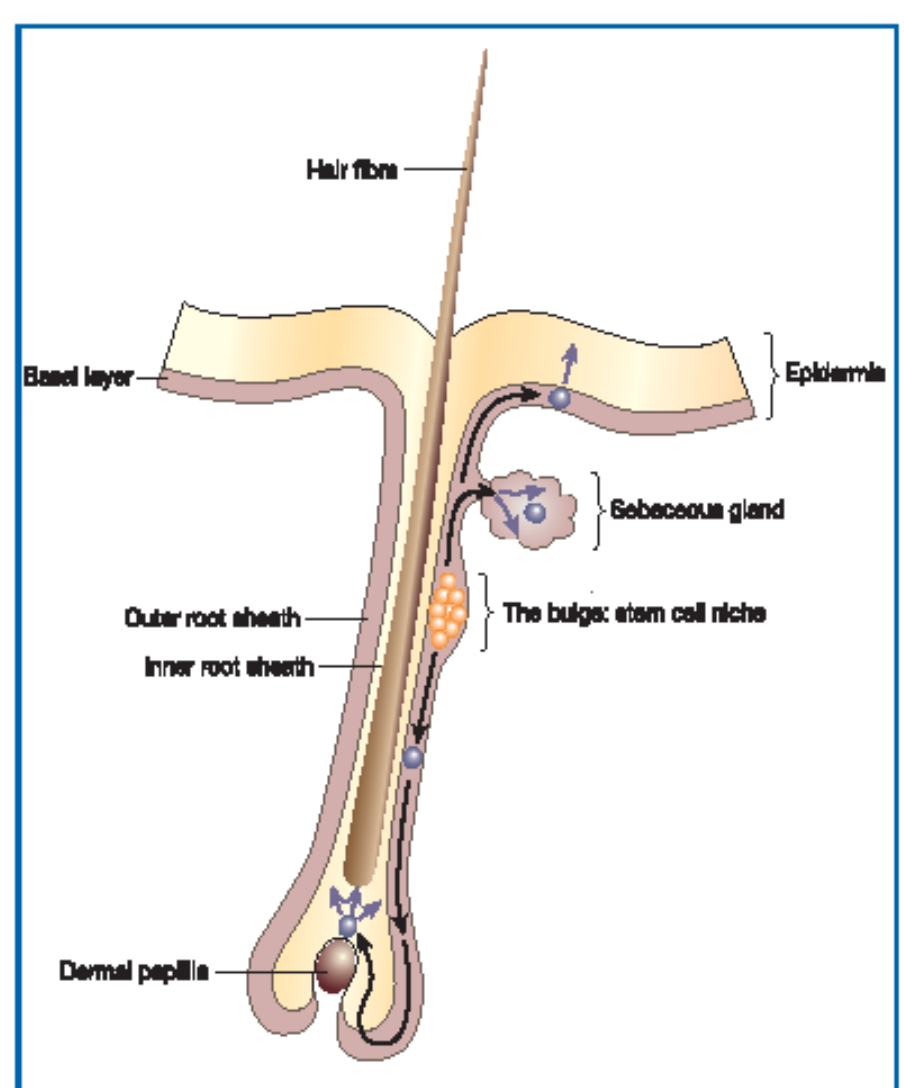
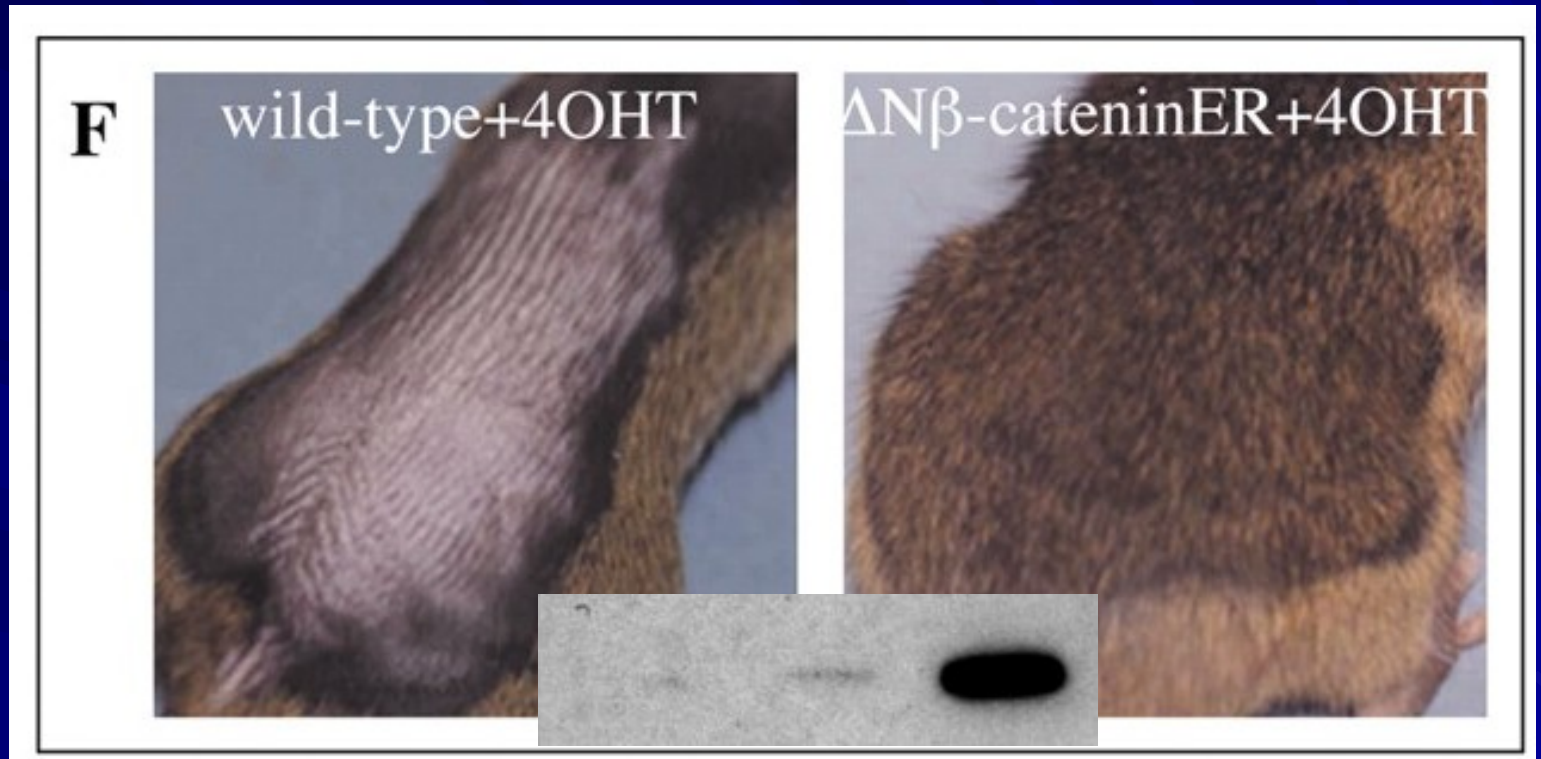

Figure 4 The hair follicle. Stem cells reside in the bulge niche. Cells can migrate upwards from here to populate the sebaceous gland and the interfollicular epidermis. Cells that migrate downwards enter the matrix where they rapidly proliferate and then differentiate to form the hair. (Adapted from ref. 90.)

Consequences of β -catenin activation in the epidermis (keratin 14 promotor):



Lo Celso, C. L. et al. Development 2004;131:1787-1799

Consequences of β -catenin activation in the brain:

midbrain (Brn4-promotor)

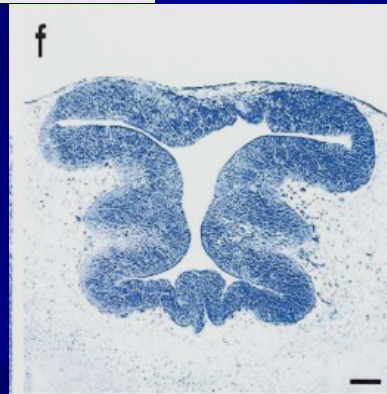
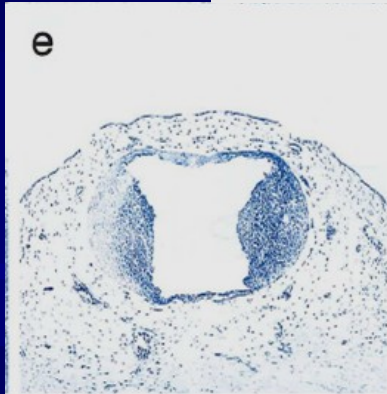
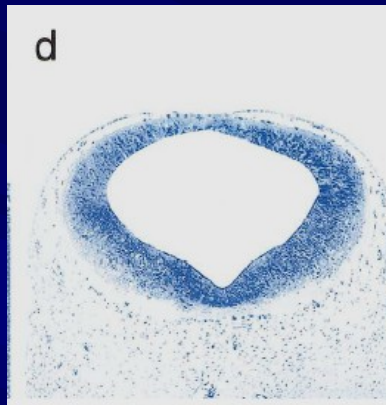

Zechner et al., 2003: Dev. Biol.;258:406-418.

cortex (nestin enhancer)

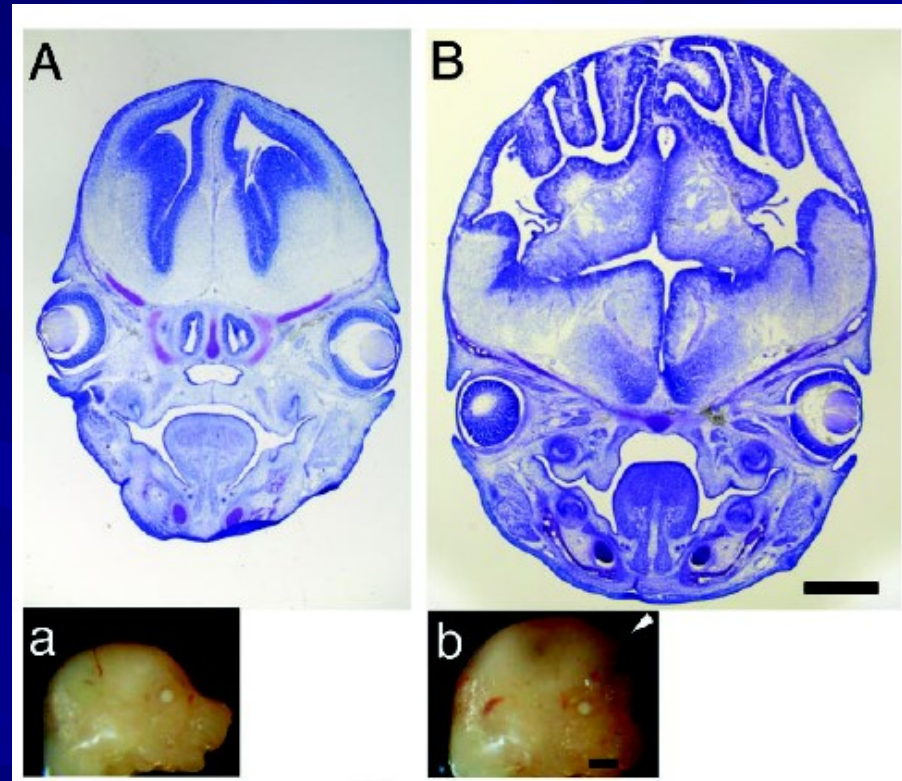

Chenn & Walsh, 2002: Science;297:365-369.

Non-canonical Wnt signalling

- e.g. Wnt5a

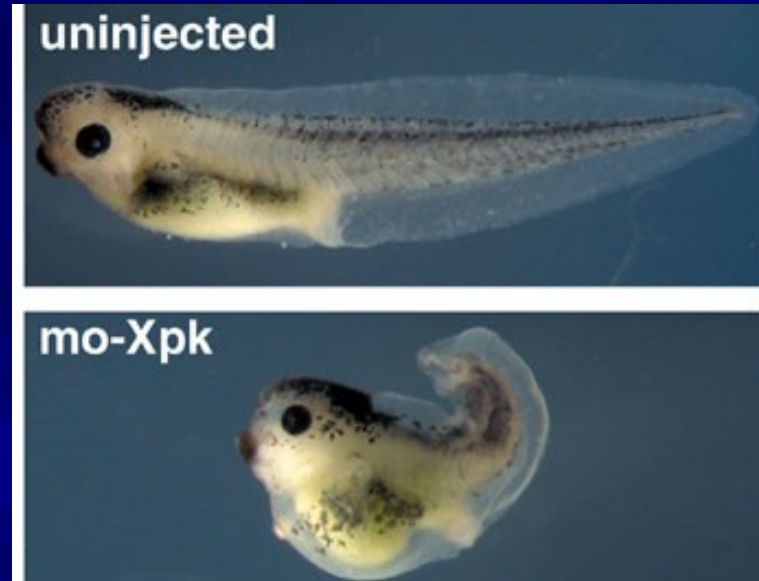

- do not induce axis duplication in *Xenopus*
- do not induce transformation of mammary cell line C57mg
- do not signal via nuclear translocation of β -catenin

Drosophila – PCP (planar cell polarity)

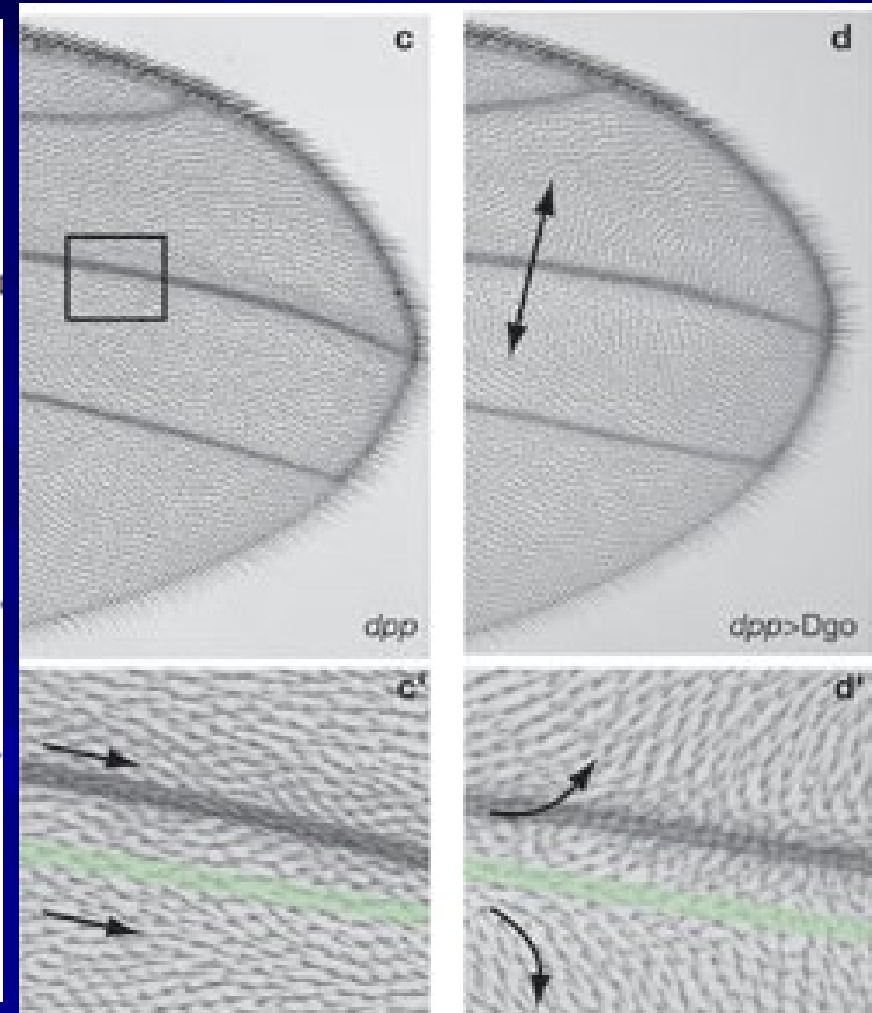
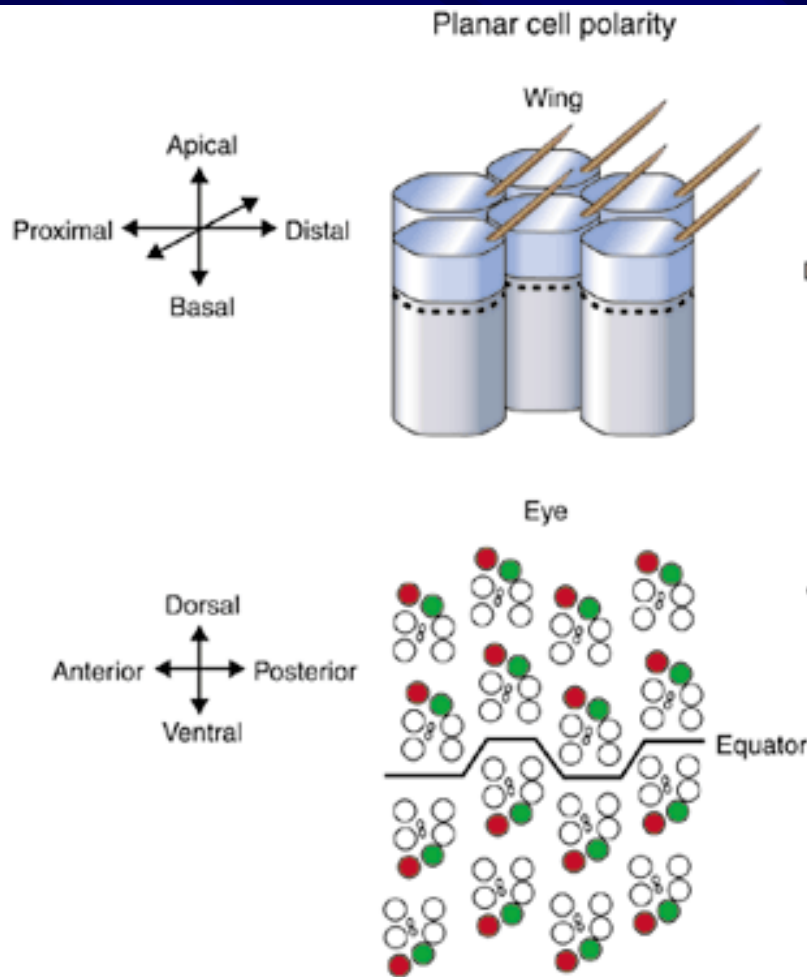

Non-canonical/PCP (Planar cell polarity) pathway defects cause neural tube closure phenotypes in mouse (and human)

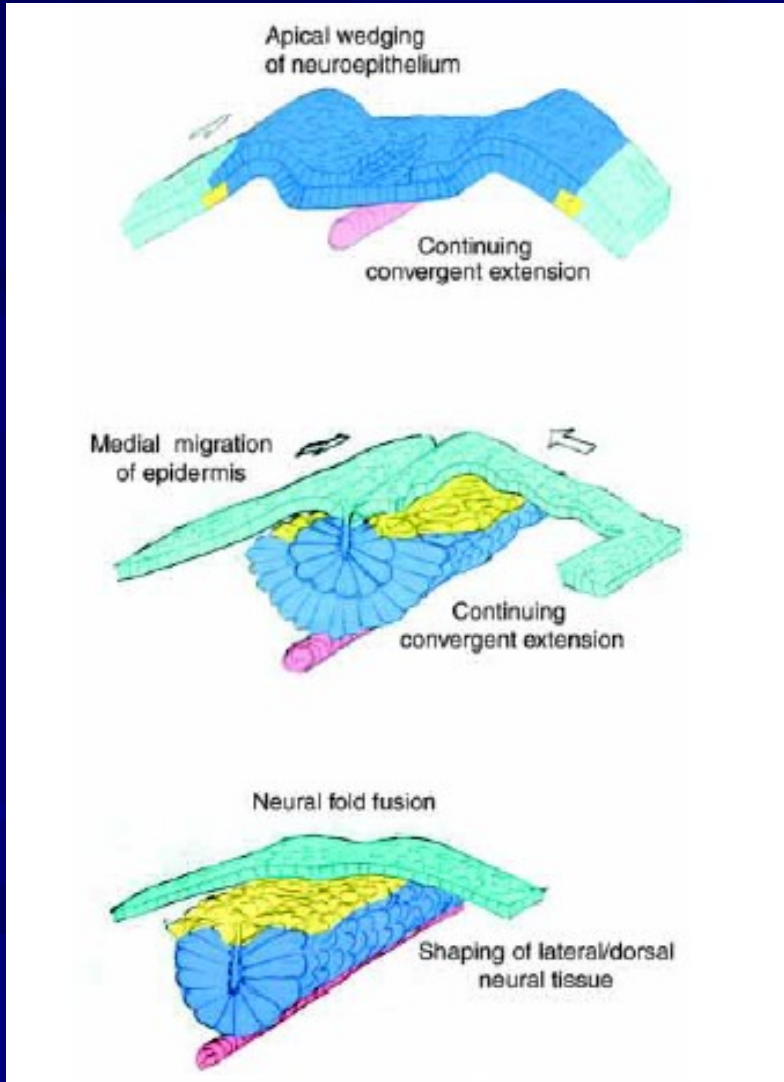

Exencephaly



Open neural tube



Fundamental question of Wnt signalling: How the specificity is achieved?

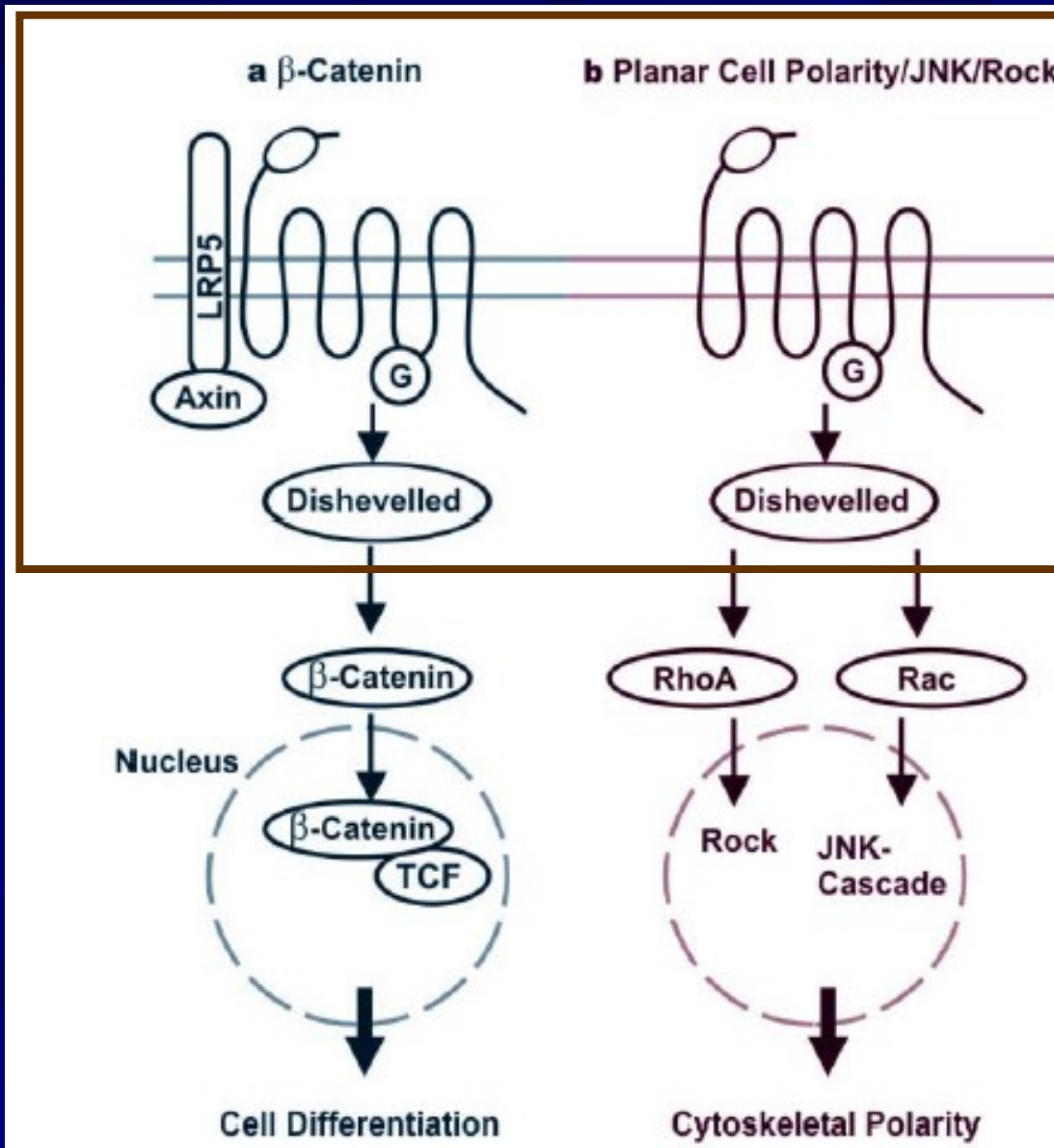

DISHEVELLED

(Dvl – mouse, XDsh – Xenopus, Dsh – Drosophila)

-phosphoprotein – phosphorylated by numerous kinases, significance often unknown

- acts between Frizzled and downstream signalling components

- required for signal transduction of all Wnt signalling pathways

Metoda 1: Western blotting

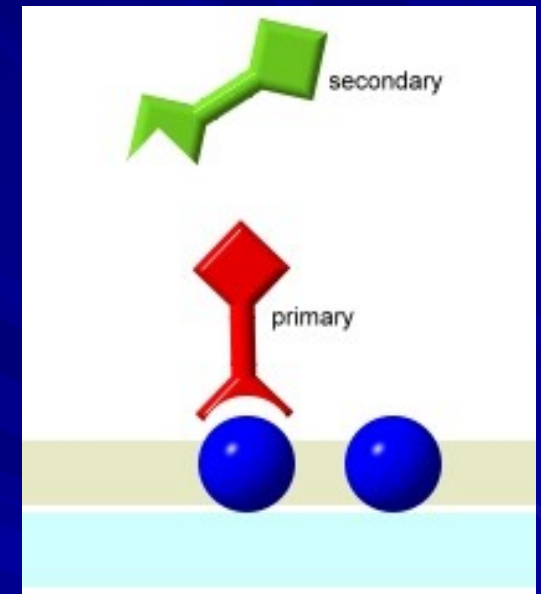
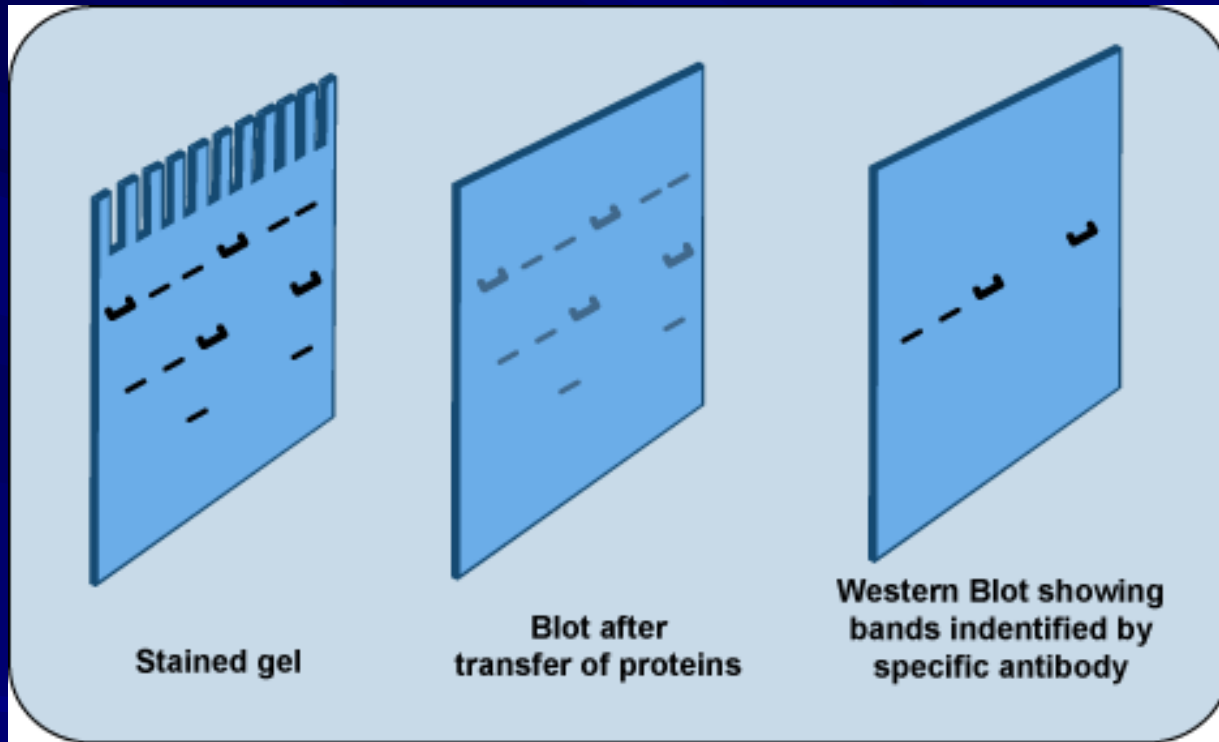

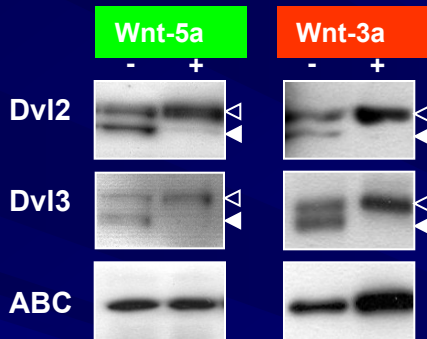

ABC – active β -catenin = β -catenin dephosphorylated on GSK3 β target sites

Dvl – Dishevelled – activated by phosphorylation detected as phosphorylation dependent mobility shift

◁ PS-Dvl

Compound	Target	Concn	Activity
PTX	Galpha i/o	100 ng/ml	No
PDBu	PKC activator	1 μ M	No
Wortmannin	PI3K	50 nM	No
LY294002	PI3K	50 μ M	No
PD98059	MEK1/2	10 μ M	No
UO126	MEK1/2	10 μ M	No
SB203580	p38	10 μ M	No
JNKII inhib	JNK	6 μ M	No
Genistein	PKC	50 μ M	No
chelerythrine	PKC	10 μ M	No
Ro-31 8220	PKC	1 μ M	No
BIM I	PKC	500 nM	No
KN93	CamKII	10 μ M	No
I3M	GSK-3	2 μ M	No
Kenpauullone	GSK-3	6 μ M	No
H89	PKA	10 μ M	No
8-Br-cAMP	cAMP pathway activator	10 μ M	No
8CPT-2Me-cAMP	EPAC activator	30 μ M	No
SQ22536	Adenylyl cyclase	100 μ M	No
MDL12330	Adenylyl cyclase	10 μ M	No
PP2	Src-like	10 μ M	No
AG1276	EGFR	10 μ M	No
ET-18-OCH3	PLC	10 μ M	No
D4476	Casein kinase 1	100 μM	Yes
staurosporin	Ser/Thr kinases, PKC	2 μ M	No

D4476 (100 μ M)

Dvl2

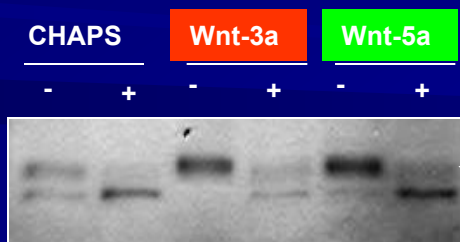

Both **Wnt-3a** and **Wnt-5a** activate Dvl2 and Dvl3 via casein kinase 1 (CK1)

Metoda 2: Immunoprecipitace

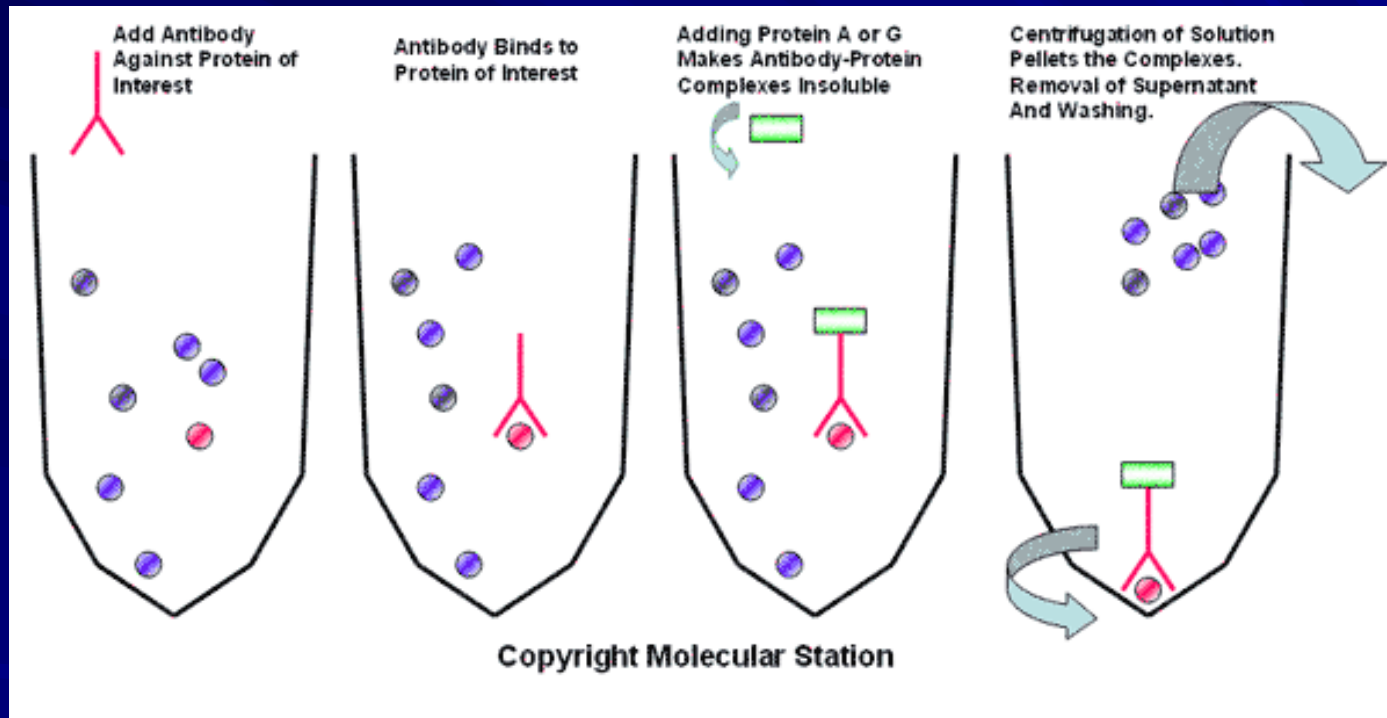

β -arrestin binds Dishevelled

Flag-Dvl3 constructs

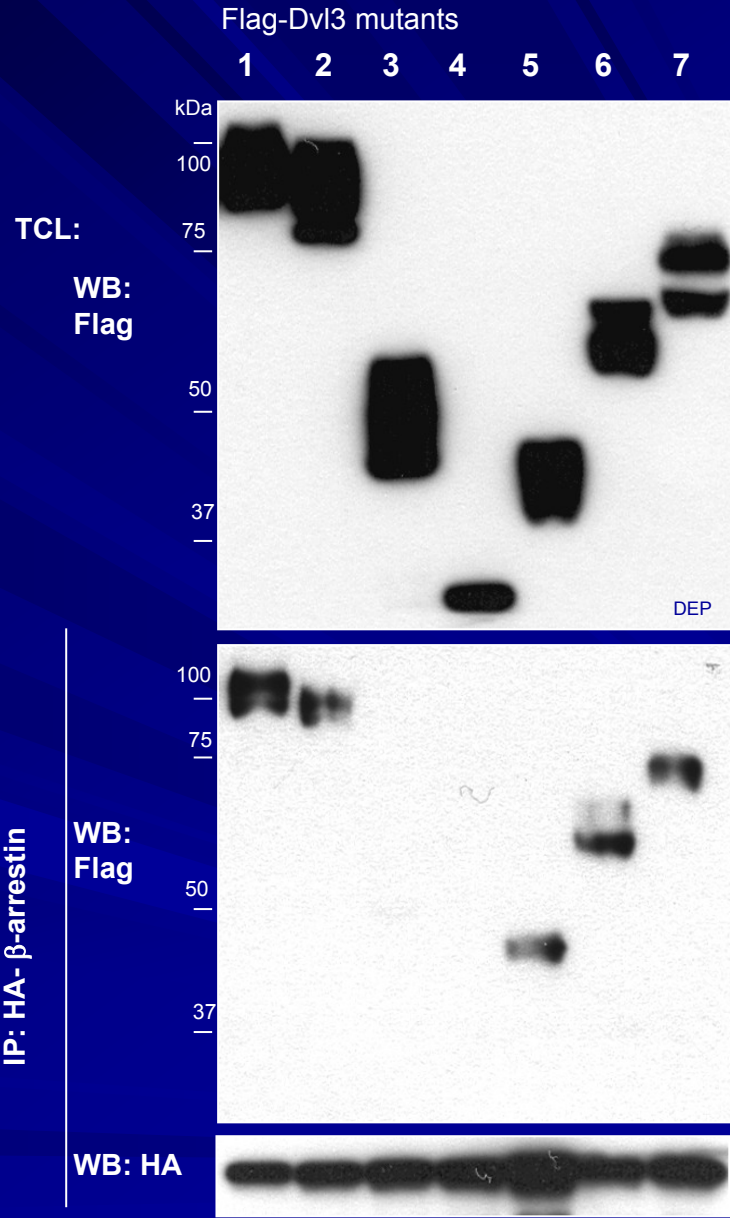
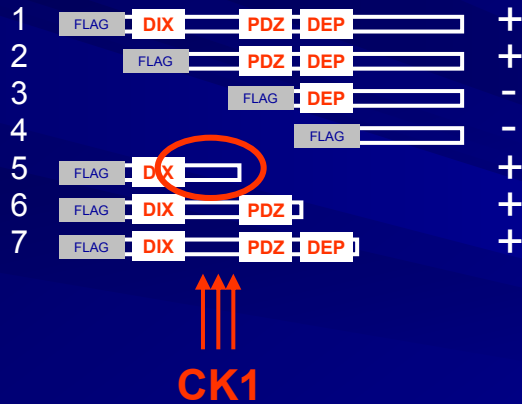

Metoda 3: Immunocytochemistry

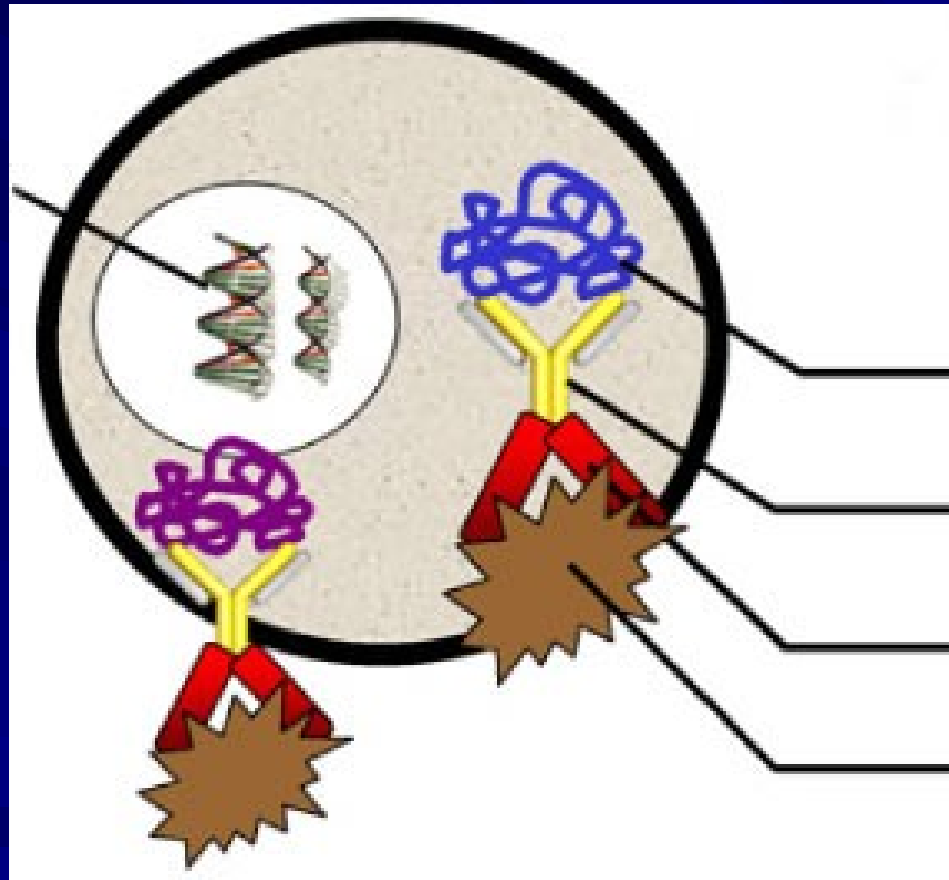

Fluorescenční proteiny

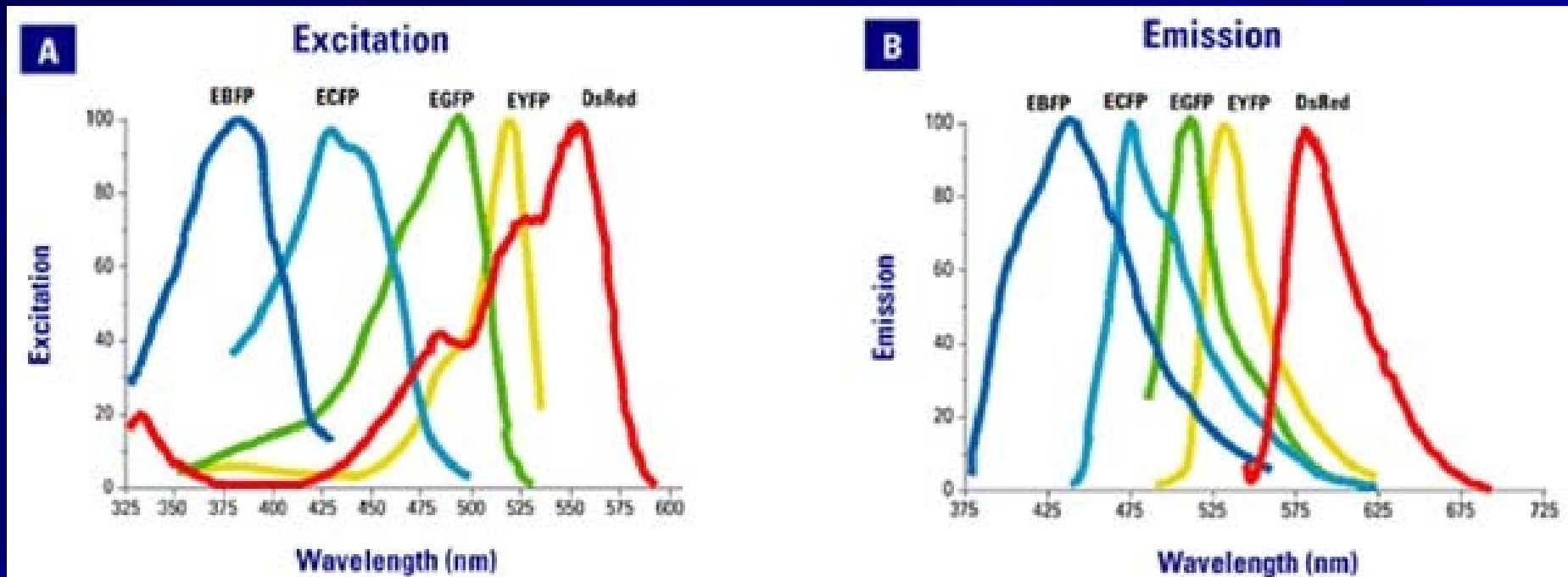

β -arrestin co-localizes with Dvl in the cytoplasm



Metoda 4: Reporter assays

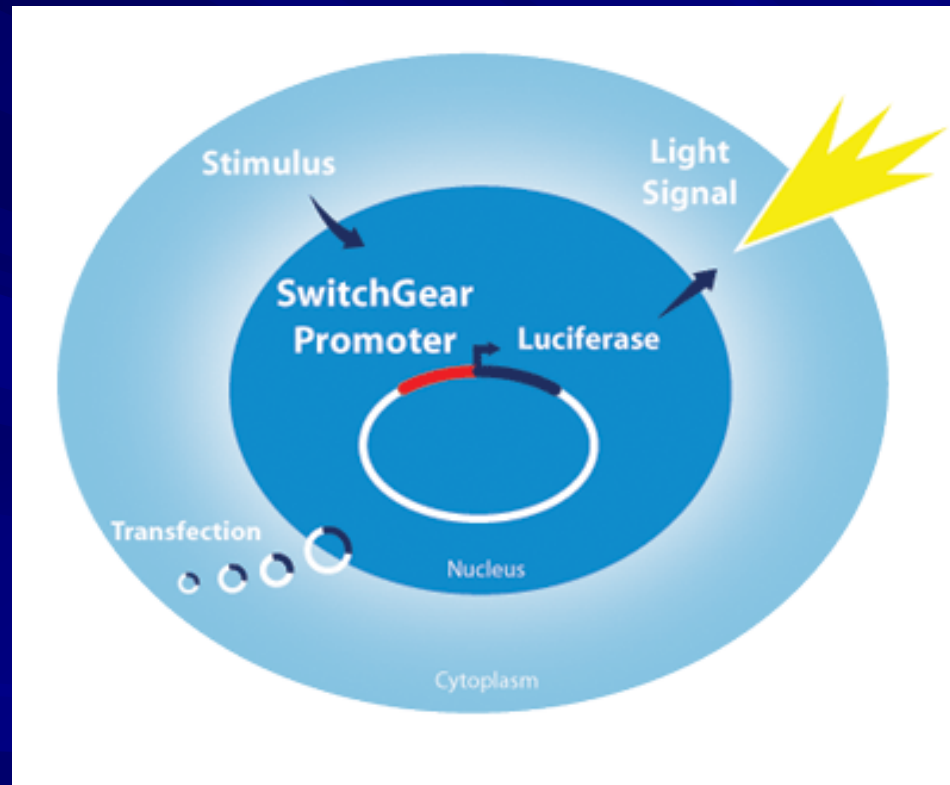

1. β -arrestin is required for β -catenin activation in vitro

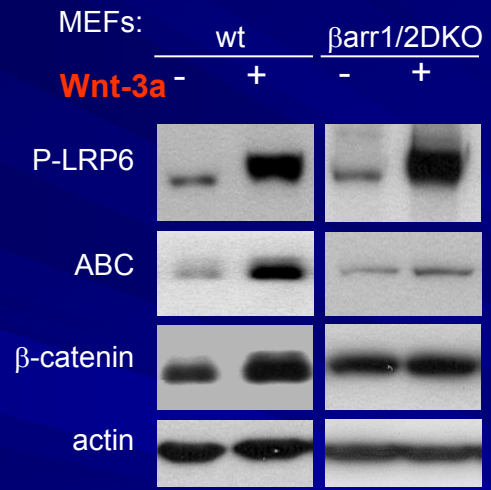
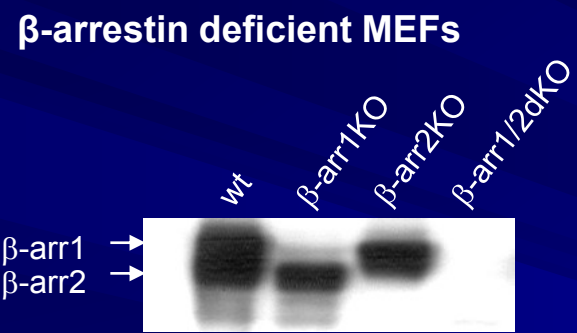

TopFlash reporter - β -catenin transcriptional activity

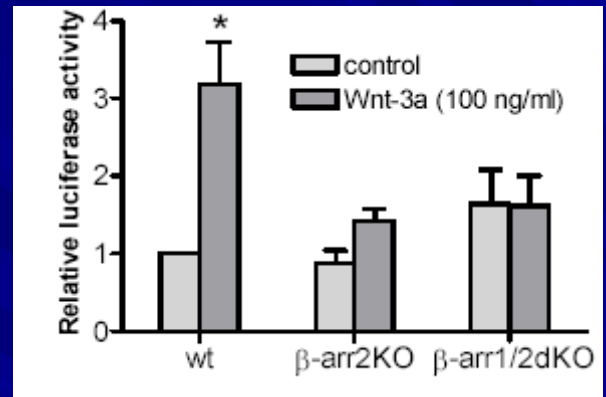

Is this relevant for Wnt signal transduction in vivo?

Metoda č. 5: In vivo analysis in *Xenopus*

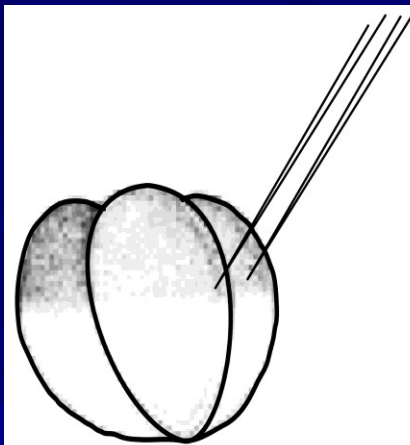

injection in 4-cell stage embryo
targets Dorsal Marginal Zone
affects primary axis formation (ventralization) and CE movements
Figures 2, 3, and Suppl Figure 1

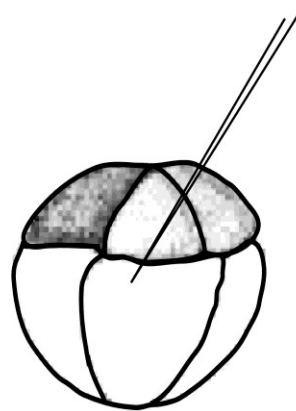

injection in 8-cell stage embryo
targets presumptive cardiac mesoderm
affects cardiac development, but avoids earlier effects on primary axis and CE
Figure 4

Metoda č. 5: In vivo analysis in Xenopus



Movie13_1.mov



Movie13_2.mov

Is β -arrestin important for the Wnt/ β -catenin signalling in vivo?

β -arrestin knockdown in *Xenopus* (*axis duplication assay*):

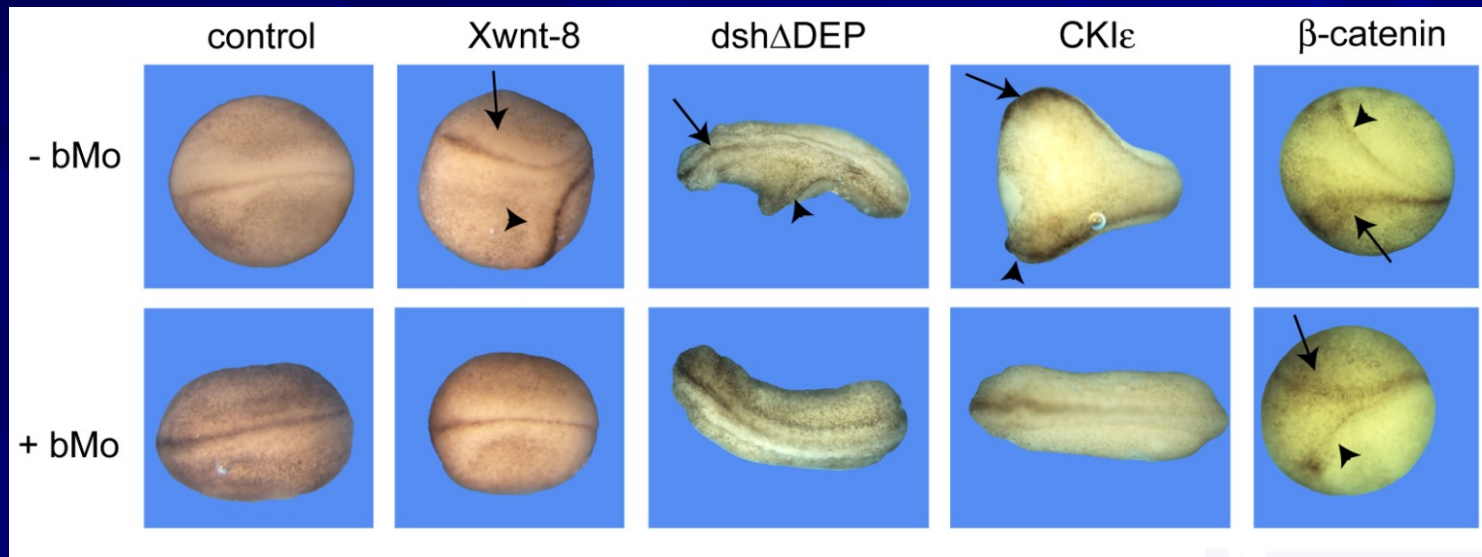

Keller explants (Xenopus)

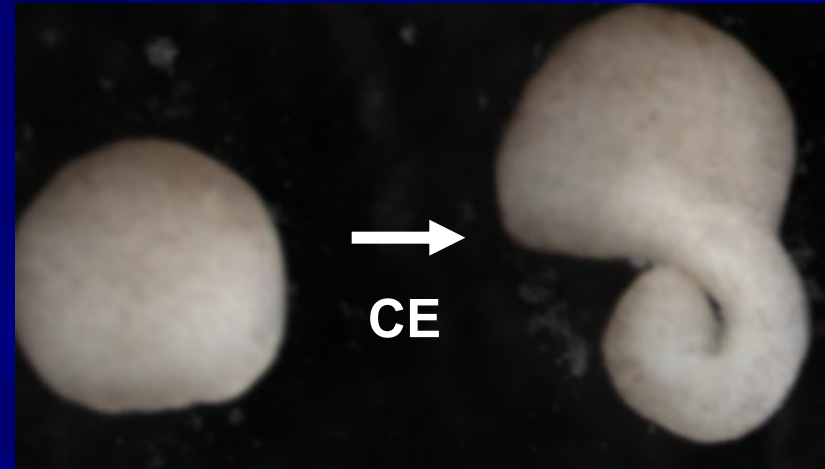
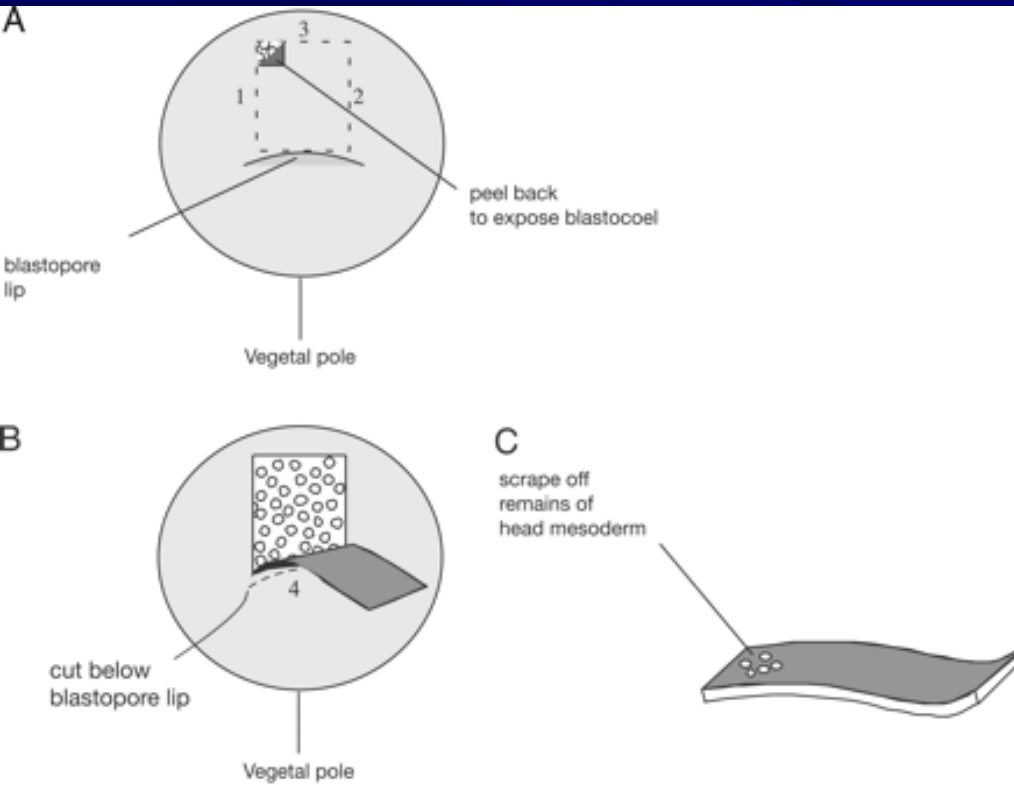

β -arrestin regulates convergent extension movements in vivo

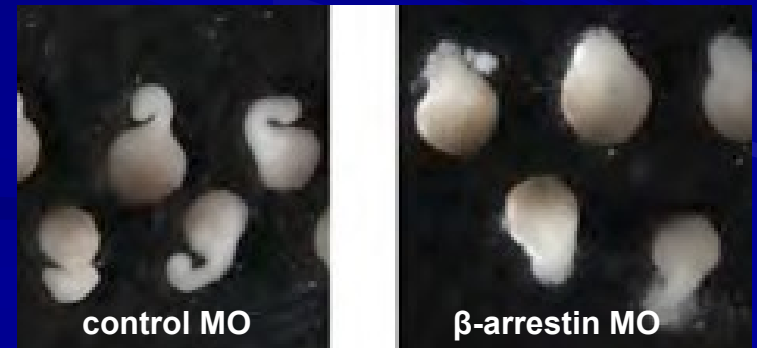

Metody č. 6: Genetické modifikace myši

Transgenní myš

Nobelova cena 2007

Mario R. Capecchi,
Martin J. Evans and
Oliver Smithies

za

„principles for
introducing specific
gene modifications in
mice by the use of
embryonic stem cells“

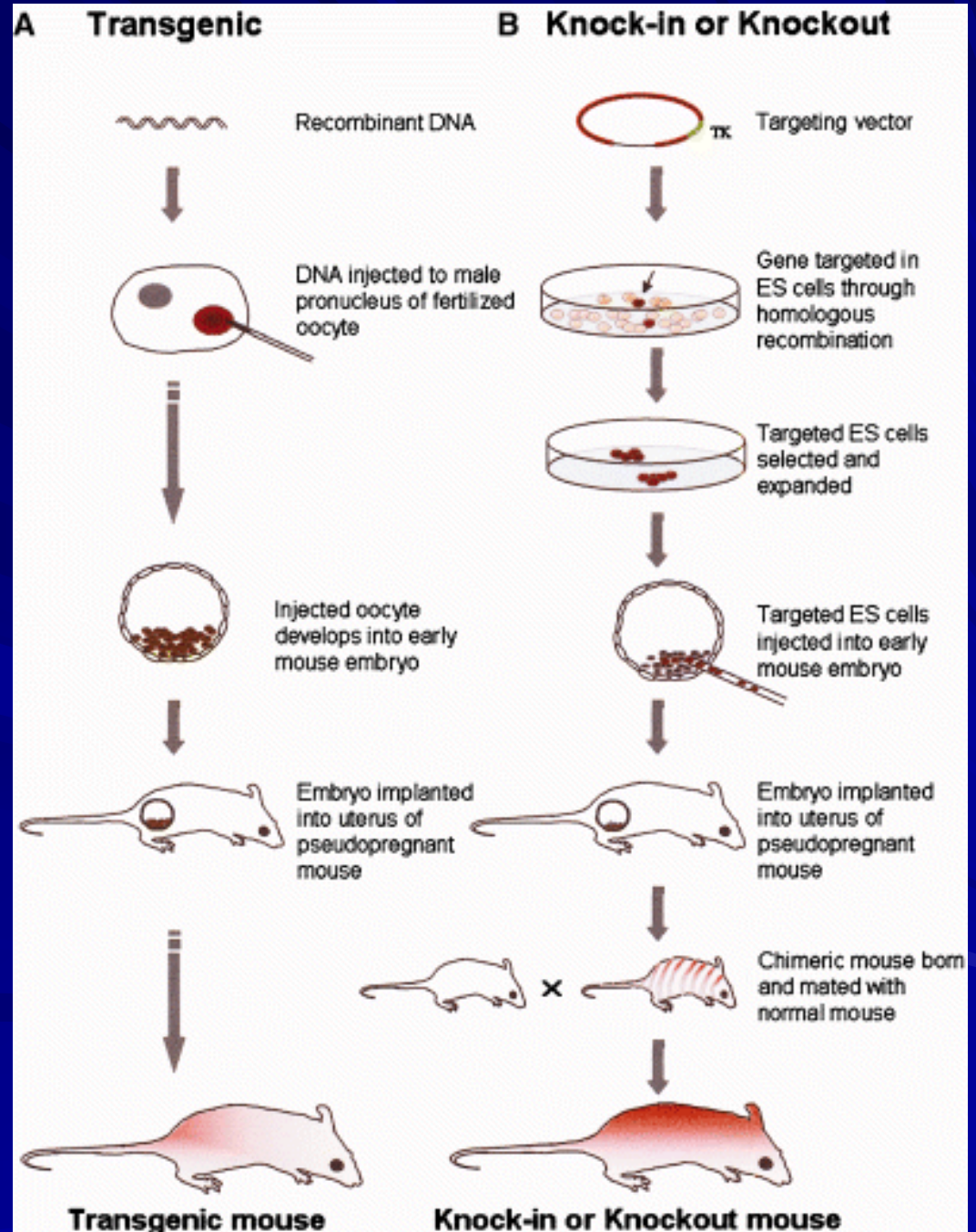

Lrp6 KO embryos display exencephaly....

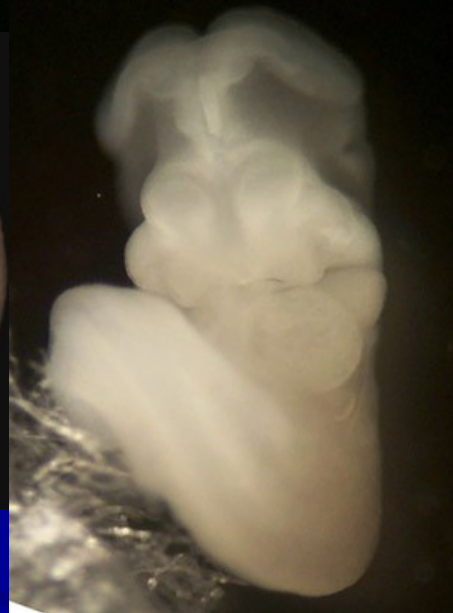
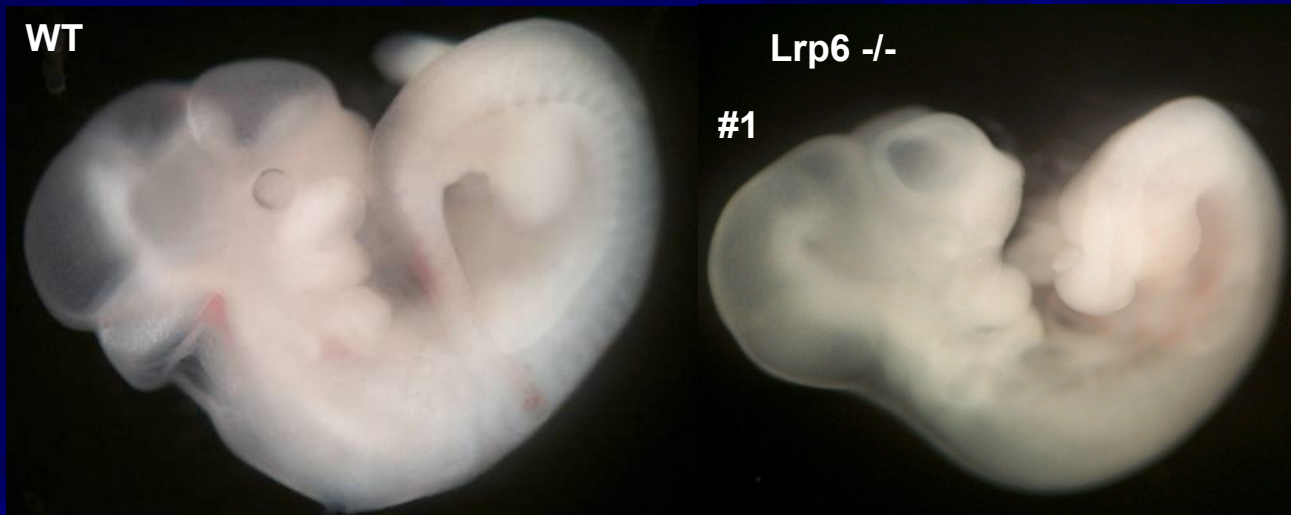

....which is rescued by loss of Wnt5a

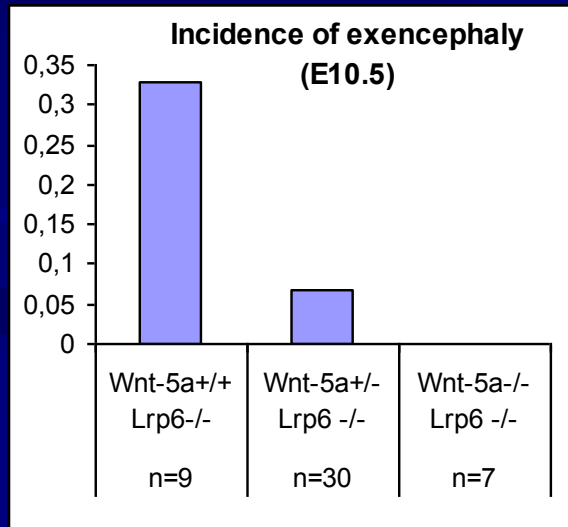

Lrp6 and Wnt5a KO show similar heart abnormalities associated with non-canonical Wnt signalling defects; heart abnormalities in Lrp6 KO are rescued by loss of Wnt5a

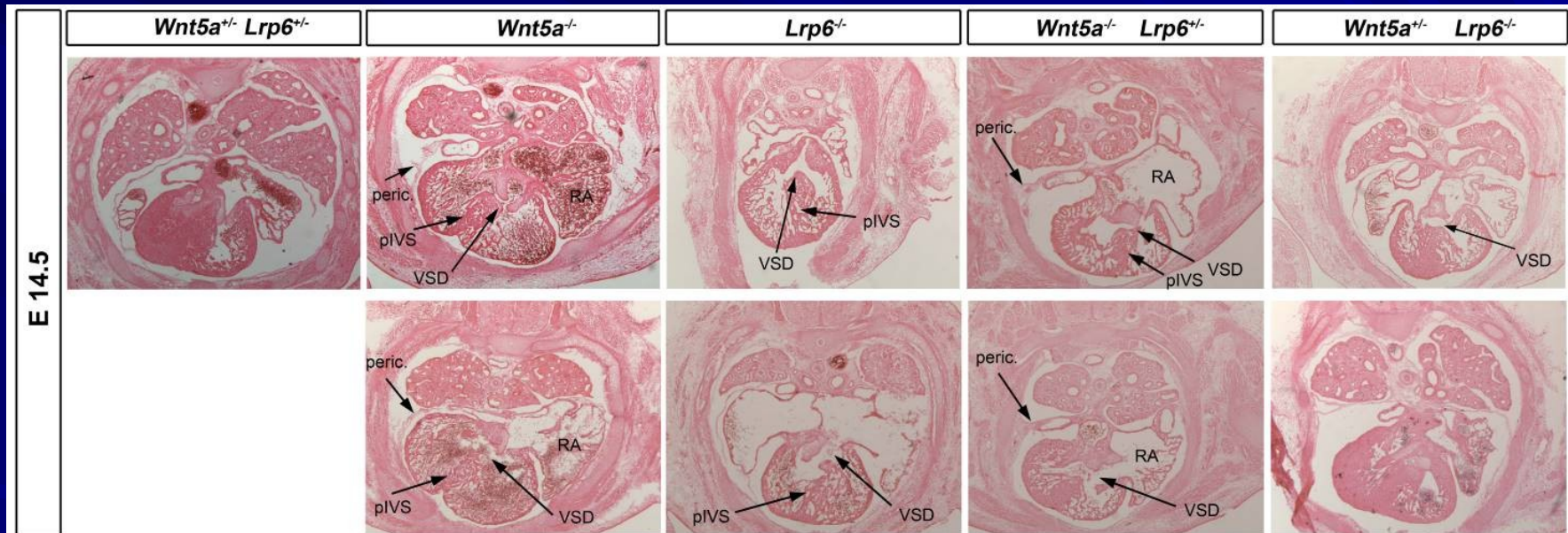
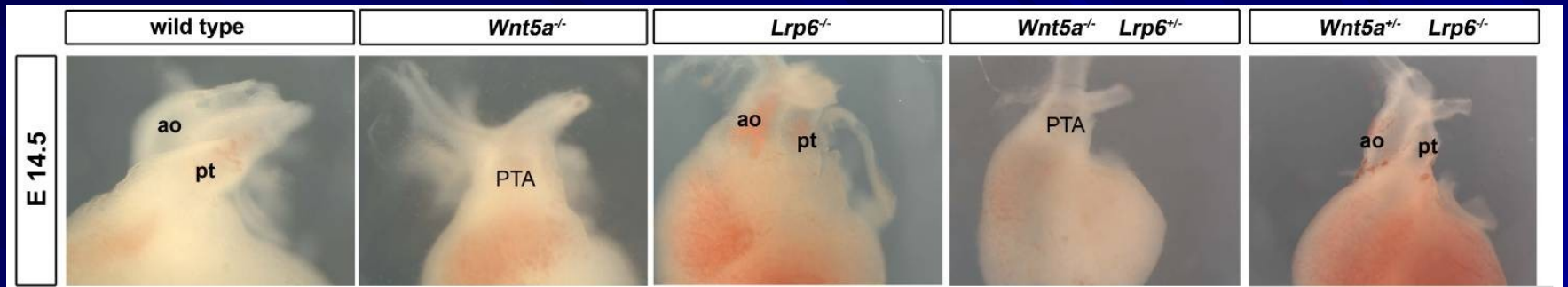

Genotype	<i>Wnt5a</i> ^{-/-} <i>Lrp6</i> ^{+/+}	<i>Wnt5a</i> ^{-/-} <i>Lrp6</i> ^{+/-}	<i>Wnt5a</i> ^{+/+} <i>Lrp6</i> ^{-/-}	<i>Wnt5a</i> ^{+/-} <i>Lrp6</i> ^{-/-}	others
outflow tract defects/total number of embryos	7/7	8/8	6/6	2/4	0/6

Metody č. 7: Afinity purifikace a hmotnostní spektroskopie

Afinitní purifikace

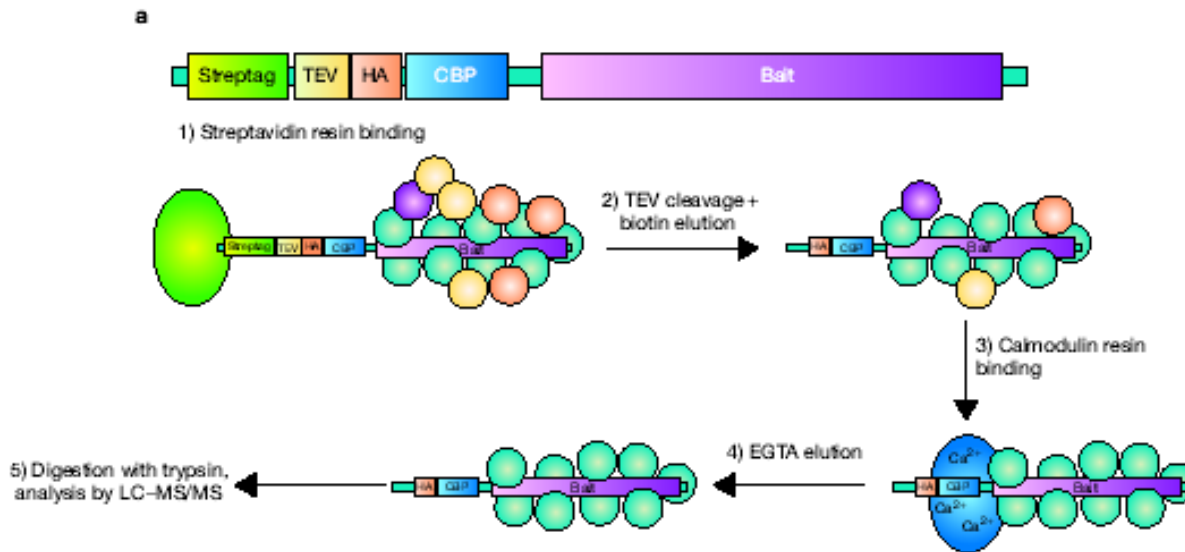

b

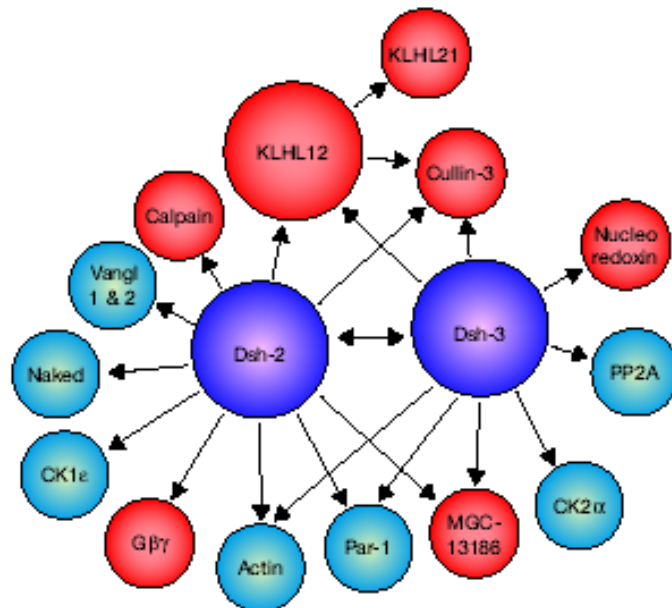

pGlue
pGlue-Dvl2
pGlue-Dvl3

Dvl2



Dvl3

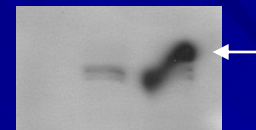

Hmotnostní spektroskopie (Mass Spec)

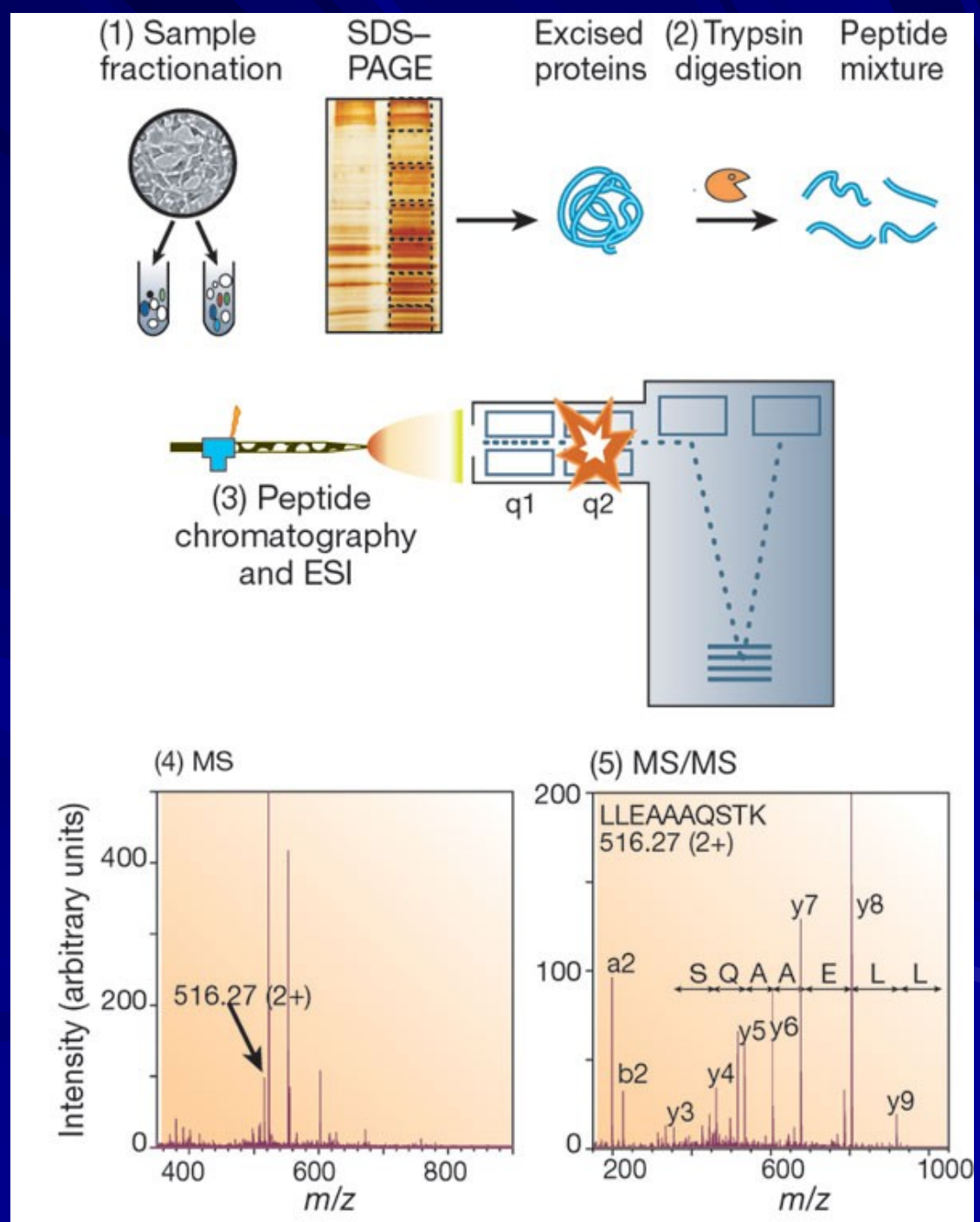

Děkuji za pozornost!

Celogenomové
techniky

Molekulární
mechanismus

Celoproteomové
techniky



Experimentální
model
(*in vitro* - tkáňové
kultury, *in vivo* -
myš, *C. elegans*,
Xenopus)

