

Dry High-Pressure Methods

Chemistry at the Earth's surface at 100 kPa

Chemistry in the Universe at high pressures and temperatures deep within the planets and stars

Laboratory:

Pressures up to 250 GPa, high temperatures ~ 7000 °C

1 bar = 100 kPa 1 Mbar = 100 GPa

p-V work during compression to 1 Mbar equivalent to approx. 1 eV chemical bond energy

In-situ observations by diffraction, spectroscopy to probe chemical reactions, structural transformations, crystallization, amorphization, phase transitions

Methods of obtaining high pressures

✘ Anvils, diamond, tetrahedral and octahedral

✘ Shock waves (km s^{-1})

✘ Explosions, projectiles

✘ Go to another planet: Jupiter

(hydrogen is metallic at 100 Gbar)

PRESSURE SCALE

Pressure, bar	System
	1 Mbar = 100 GPa
10^{-12}	high vacuum chamber
1	atmospheric pressure
1.5	kitchen pressure cooker
2.0	car tire
50	a lady in stilleto heels
60	breakdown of human nervous system - divers
73.8	critical pressure of CO ₂
150	autoclave (safety burst disc)
221.2	critical pressure of H ₂ O
10^3	pressure at the bottom of the ocean (11 km)
2.10^3	LDPE
10^4	Earth crust (30 km)
10^5	synthetic diamond production
$3.4.10^6$	pressure at the center of the Earth (6378 km)
10^7	Saturn, Jupiter, metallic hydrogen
10^8	neutron stars

Dry High-Pressure Methods

Pressure techniques useful for synthesis of unusual structures
TD metastable yet kinetically stable when pressure released
= pressure and temperature quenching
reconstructive transformation hindered at low temperature
insufficient thermal energy for bond-breaking

- **high pressure phases**
- **higher density**
- **higher coordination number**
- **higher symmetry**
- **transition to from nonmetal to metal**
- **band mixing**

Pressure/Coordination Number Rule: increasing pressure – higher CN
Pressure/Distance Paradox: increasing pressure – longer bonds

Dry High-Pressure Methods

Gray Sn (diamond type) stable below 13 °C

Coordination number 4, Sn-Sn bond length 281 pm

White Sn

Coordination number 6, Sn-Sn bond lengths 302 and 318 pm

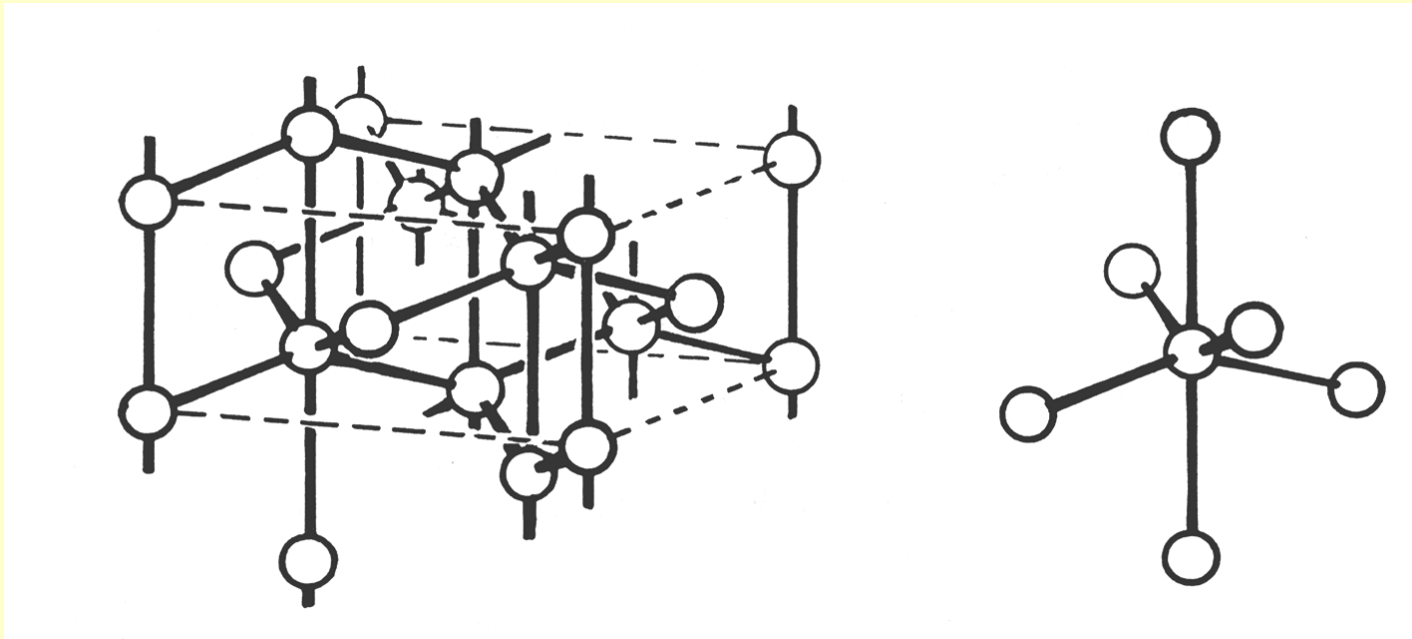

Dry High-Pressure Methods

Examples of high pressure polymorphism for some simple solids

Solid	Normal structure and coordination number	Typical transformation conditions P(kbar)	Typical transformation conditions T(°C)	High pressure structure and coordination number
C	Graphite 3	130	3000	Diamond 4
CdS	Wurtzite 4:4	30	20	Rock salt 6:6
KCl	Rock salt 6:6	20	20	CsCl 8:8
SiO₂	Quartz 4:2	120	1200	Rutile 6:3
Li₂MoO₄	Phenacite 4:4:3	10	400	Spinel 6:4:4
NaAlO₂	Wurtzite 4:4:4	40	400	Rock salt 6:6:6

High-Pressure Phase Transformations

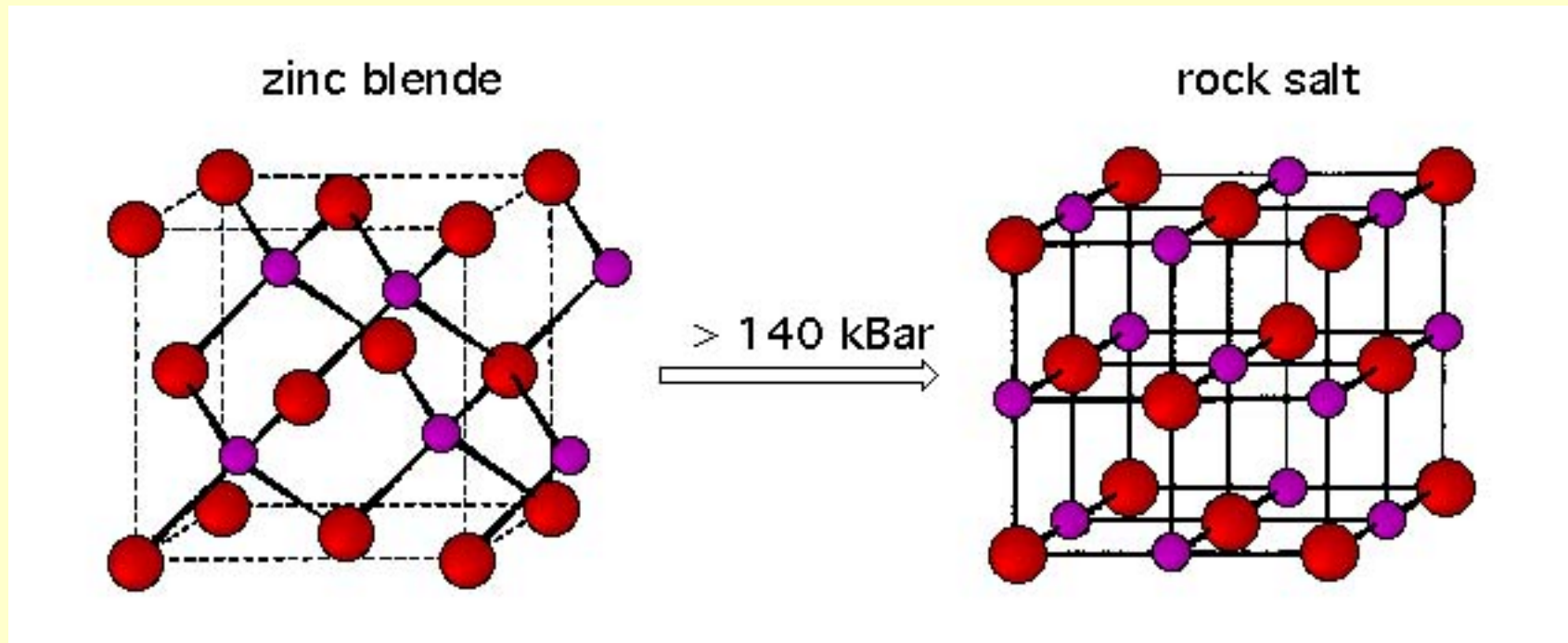

Phase Diagrams

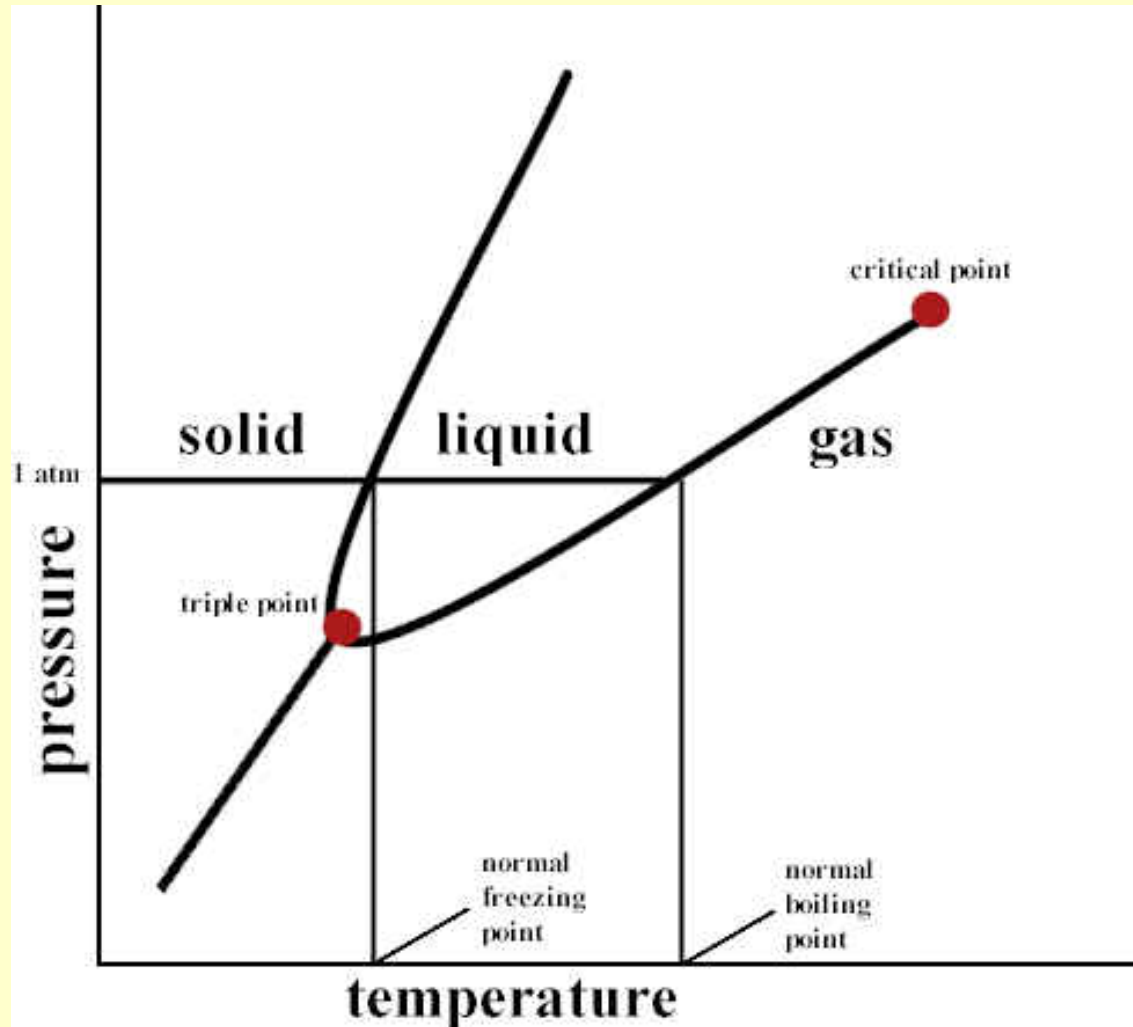

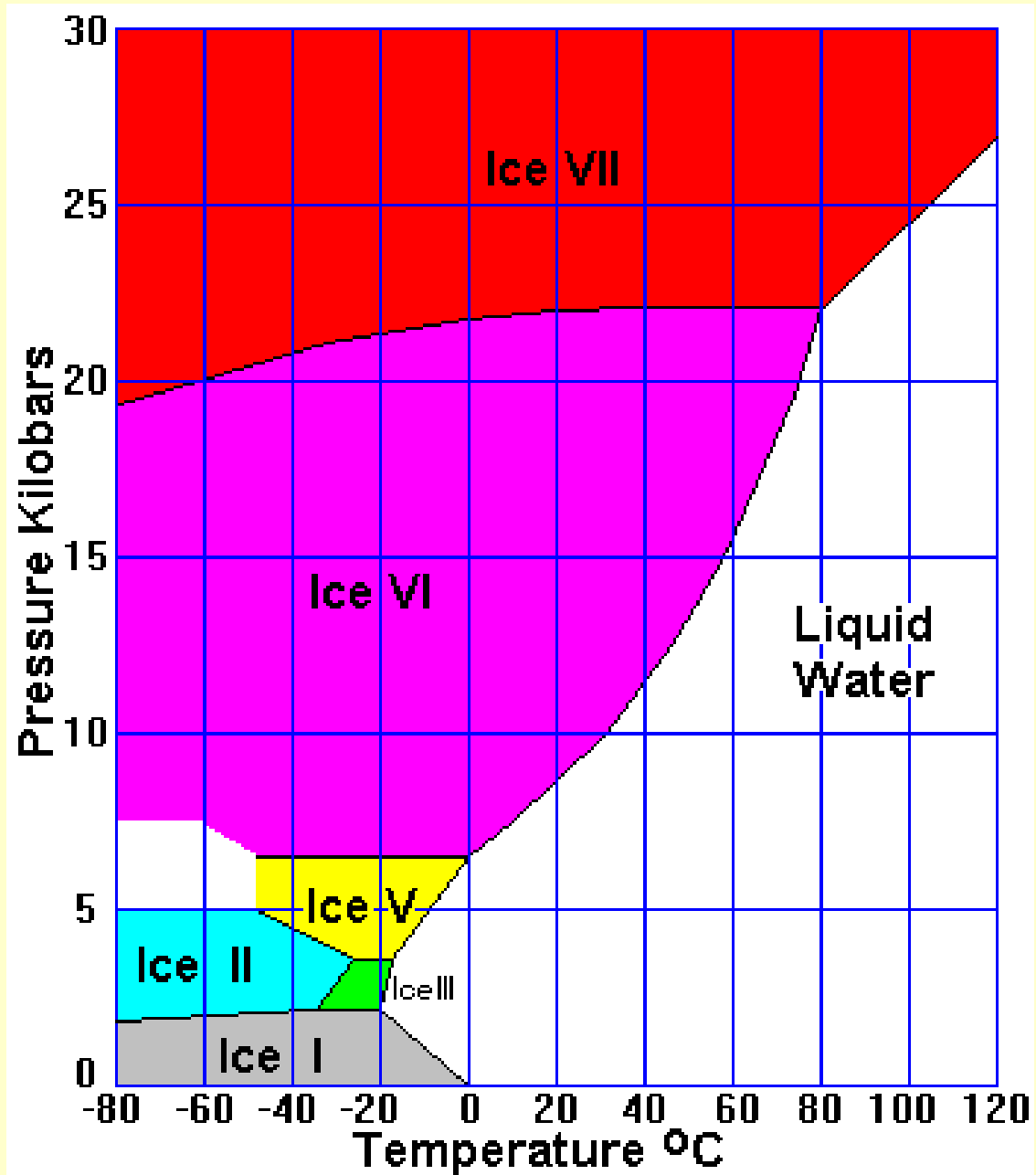

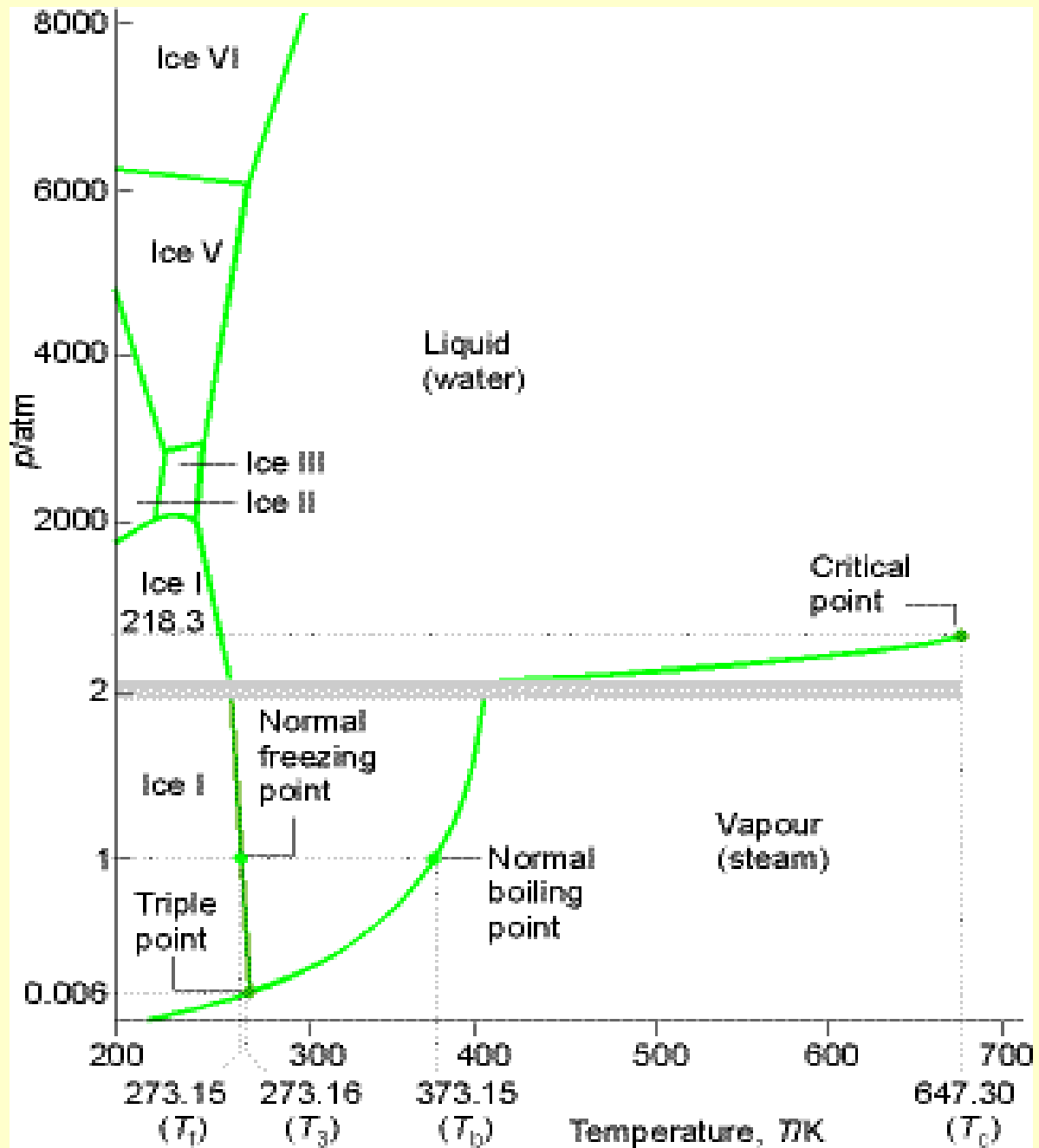

Water

12 phases of ice up to 8 GPa

Ice-VII m.p. 100 °C

Ice-X fluorite, ionically conductive above 10 GPa

Equalization of O-H covalent and hydrogen bonds above 60 GPa

Max pressure attained for water 210 GPa

Ca

ccp at ambient pressure

bcc (!) above 20 GPa 4s-3d mixing, Ca become a transition metal

MgSiO₃ most abundant silicate mineral within our planet !

pyroxene (silicate chains)

ilmenite > garnet > perovskite Si CN = 6

Condensed gases

H₂ metallic conductivity in dense fluid hydrogen

H₂⁺ H₂⁻

NO₂ + N₂O NO⁺ NO₃⁻ calcite

CO₂ heating at 10-20 GPa sp³ bonded CO₄ cristobalite, tridymite

40 GPa quartz (noncentrosymmetric)

N₂ semiconducting oligomers (-N-) _x at 100-240 GPa

Earth's Core

3.4 Mbar = 340 GPa, 6000 K

ϵ -Fe hcp

Reaction Equilibrium and Kinetics

$$\Delta G^0 = -RT \ln K$$



$$\left(\frac{\partial RT \ln K}{\partial P}\right)_T = -\Delta V^0$$

$$\left(\frac{\partial \ln k}{\partial T}\right)_P = -\frac{E_a}{RT}$$

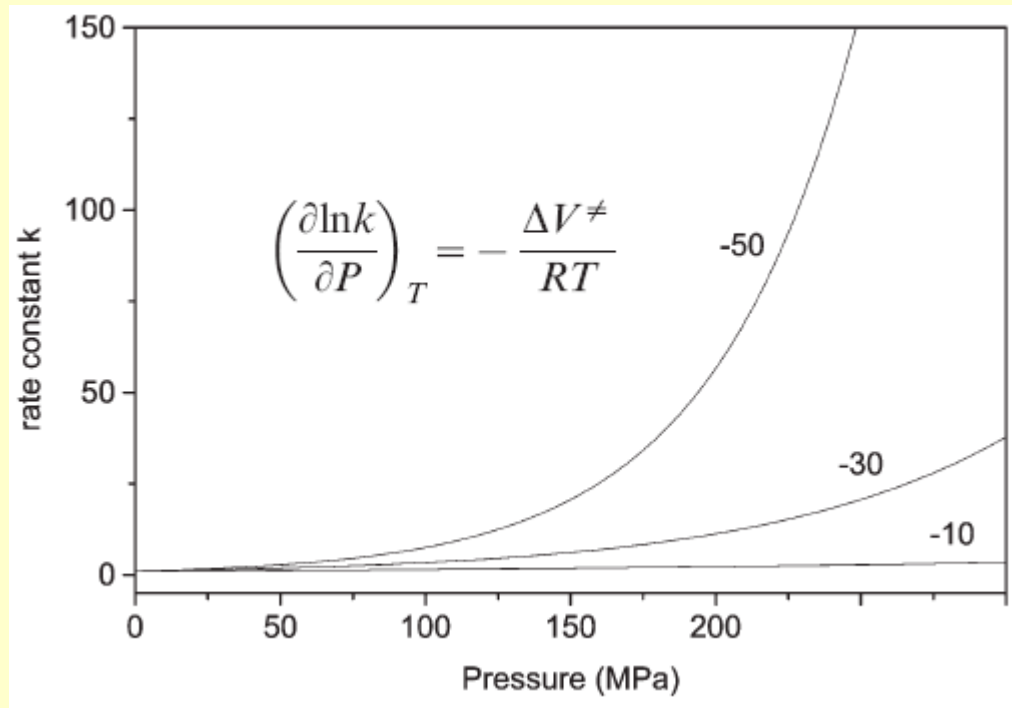

Room-temperature pressure dependence of the rate constant for different activation volume values (in $\text{cm}^3 \text{mol}^{-1}$)

Reaction Kinetics

The activation volume ΔV^*

the volume difference between the transition state complex and the reactants

associative type = the rate determining step involves the formation of a covalent bond

negative ΔV^*

dissociative type = the breaking of a covalent bond

positive ΔV^*

Diamond Anvil Cell

Diamond anvil cell

$$p = F/A$$

$$p = 40 \text{ GPa}$$

$$A_{\text{table}} / A_{\text{culet}} = 10 : 1$$

$$A_{\text{culet}} = 100\text{-}200 \mu\text{m}$$

laser heating $T > 2500 \text{ }^\circ\text{C}$

Re, steel gasket

Diamond transparent

to radiation from IR to X-ray

pressure transmitting medium:

solid Ar, N₂, O₂,

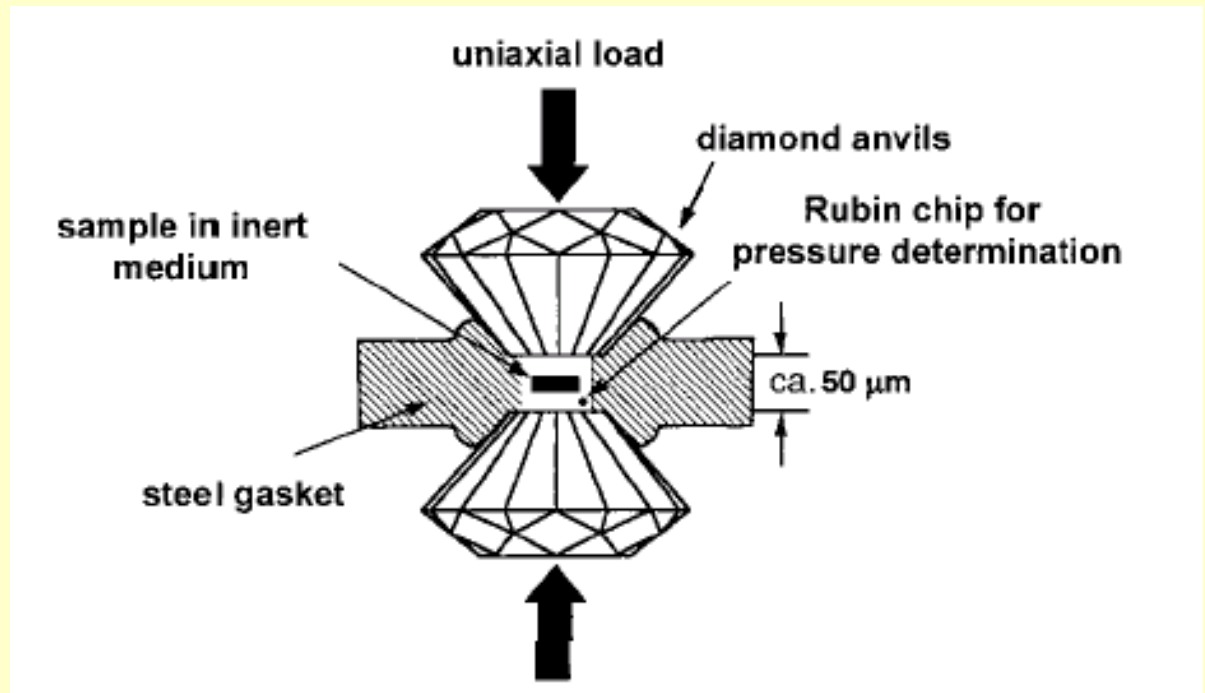

Diamond Anvil Cell

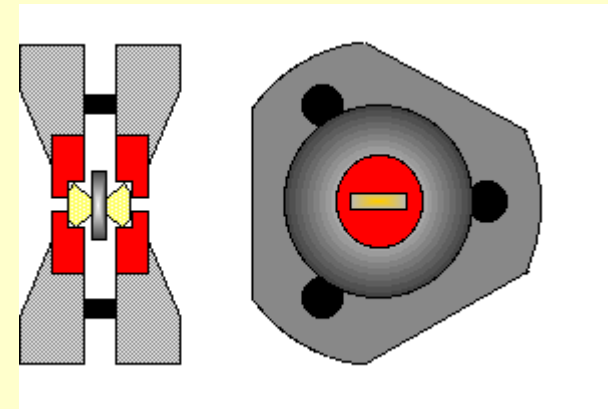
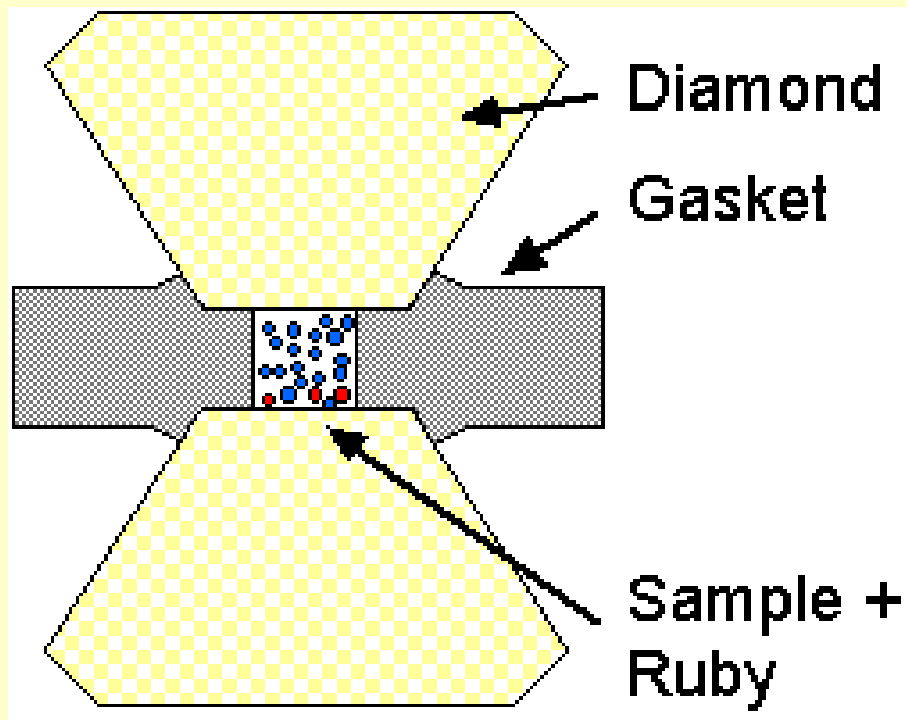

Diamond Anvil Cell

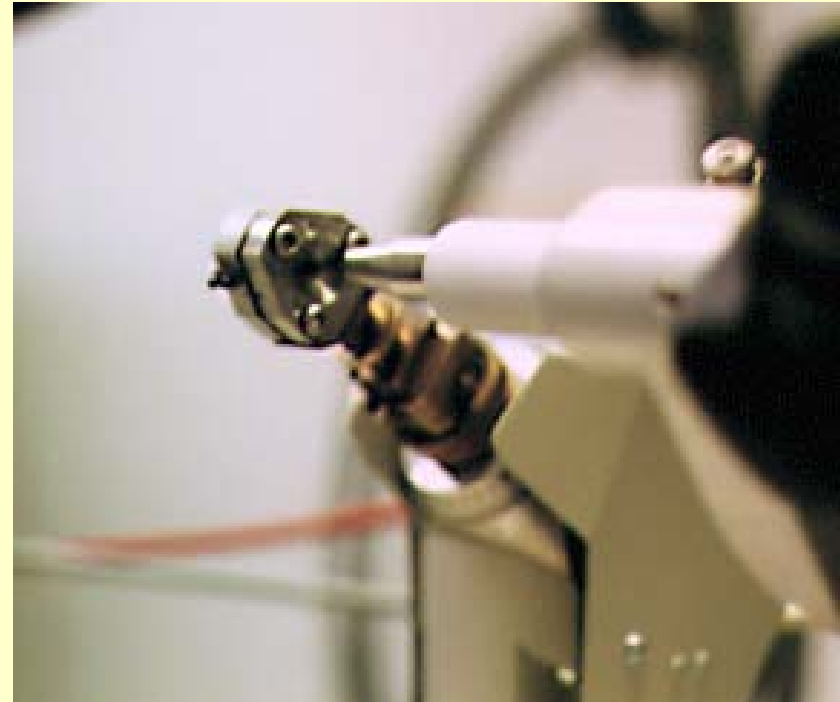
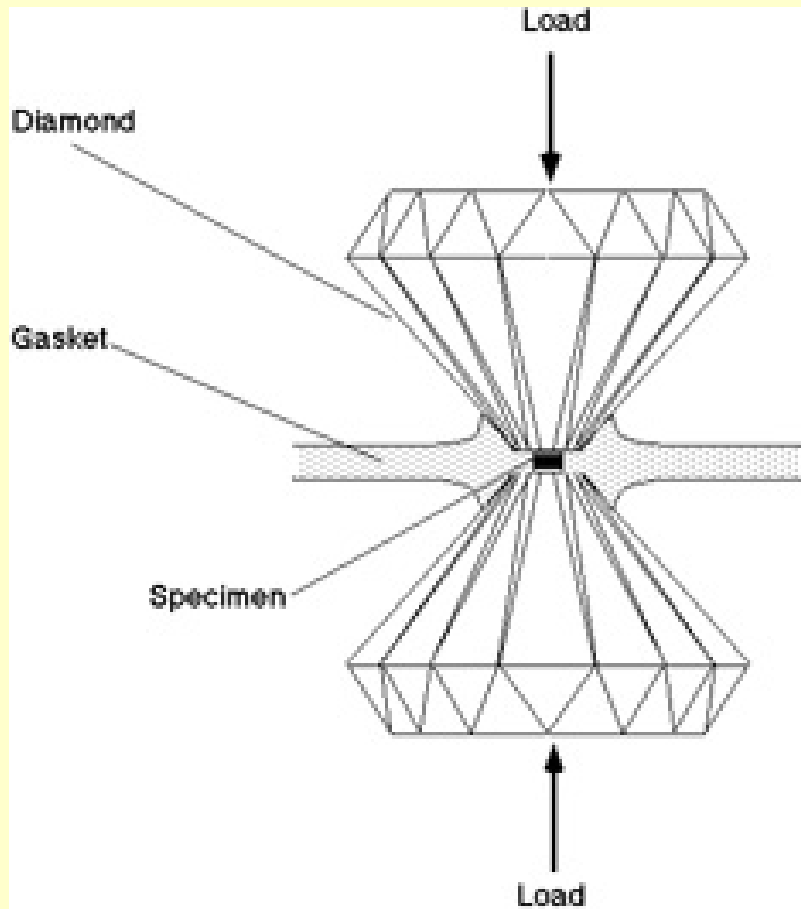

Dry High-Pressure Methods

Calibrating a high pressure diamond anvil

- Ruby - fluorescence transition
- Bi, Tl, Ba pressure induced phase transition

Ruby = Cr doped corundum

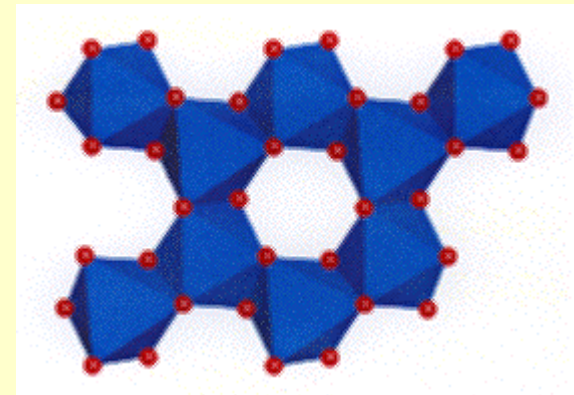

High pressure synthesis

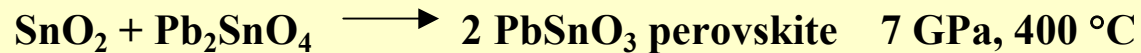

At ambient pressure only SnO₂ and PbO products

Rb₂KCrF₆

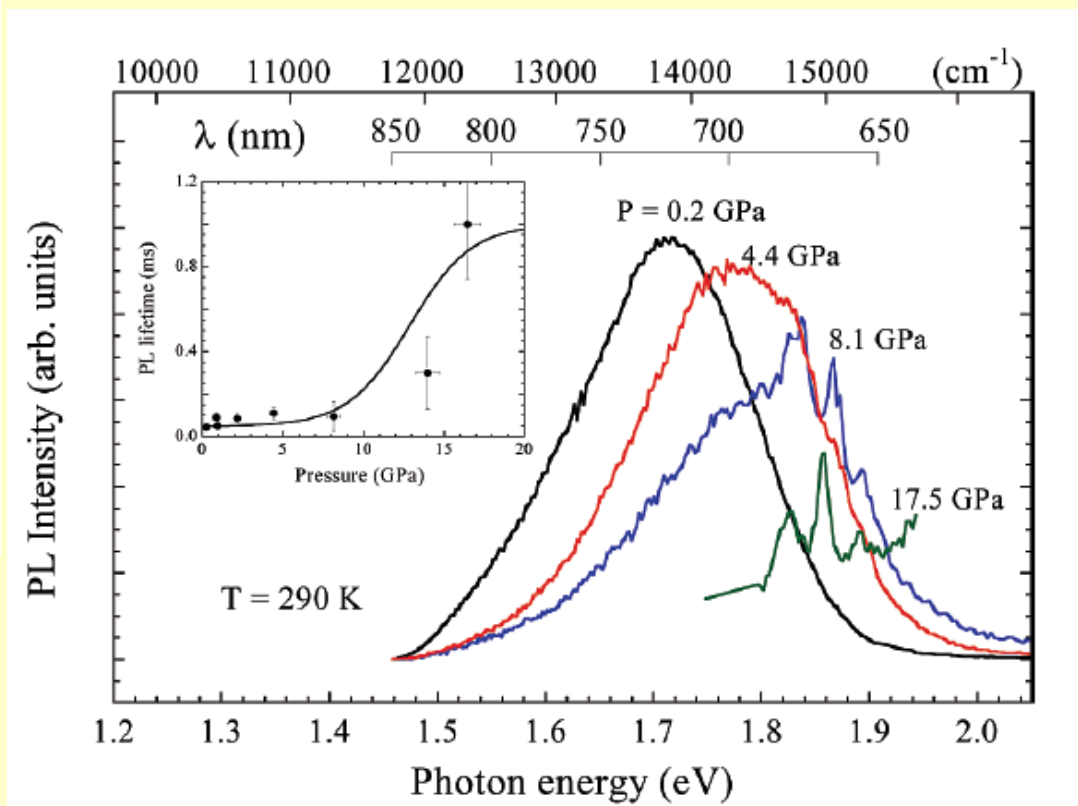
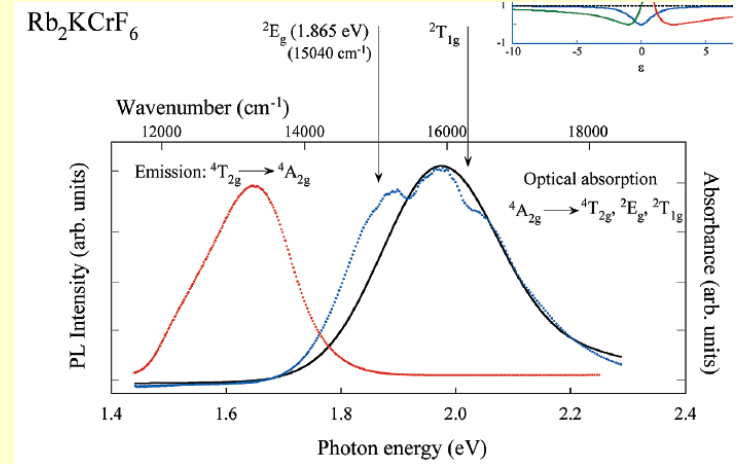
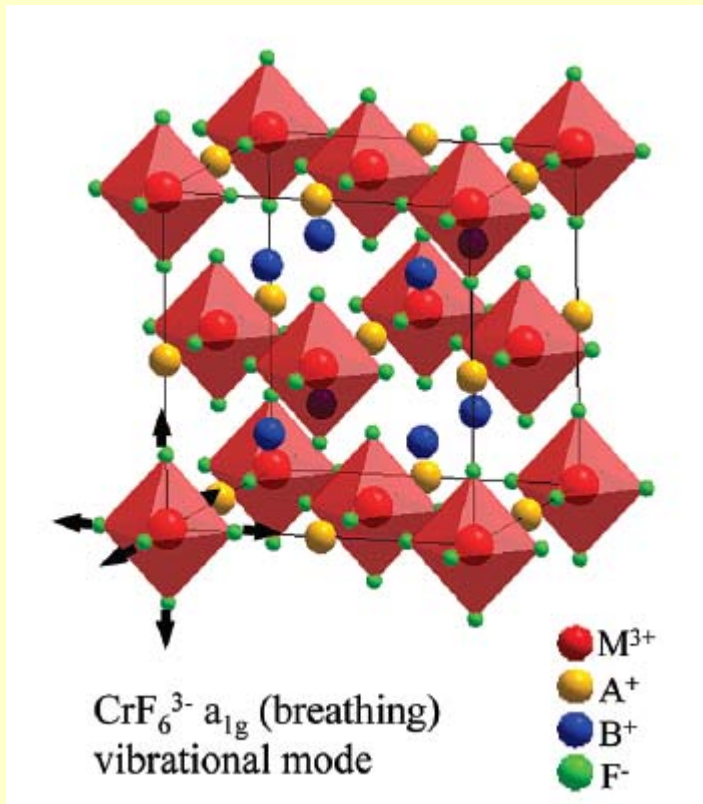

High Pressure Two-Die Belt-Type Apparatus

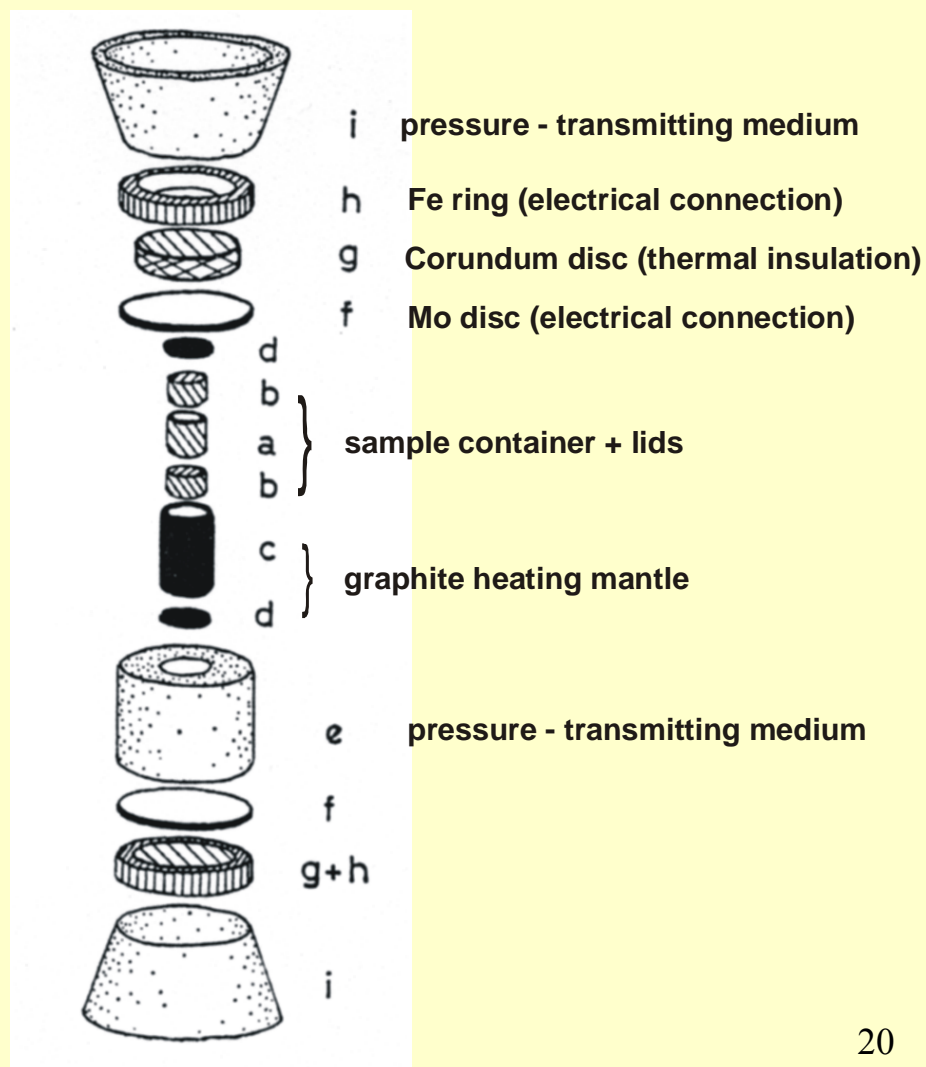
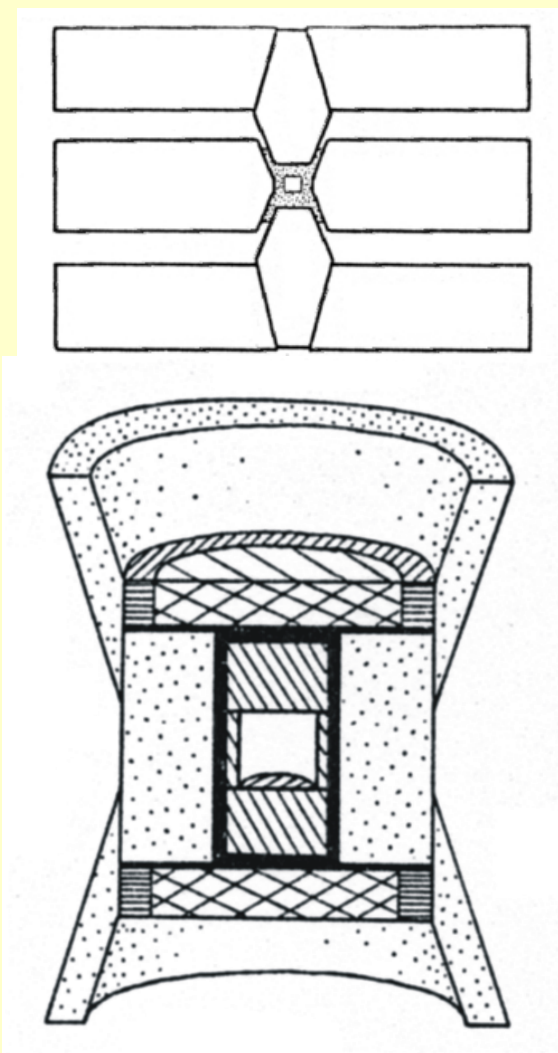

Synthesis of Diamonds

The hardest known substance, the highest thermal conductivity

Difficult to transform graphite into diamond

Industrial diamonds (GE) made from graphite around 3000 °C and 13 GPa

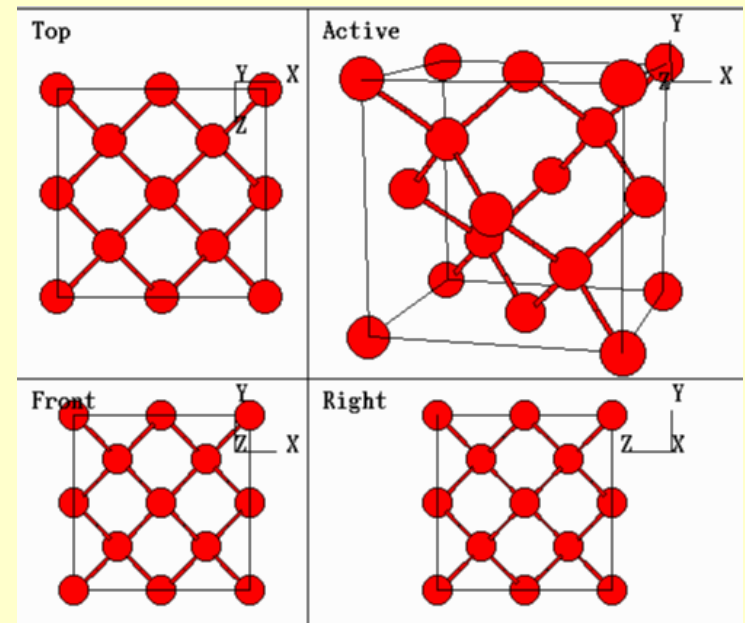
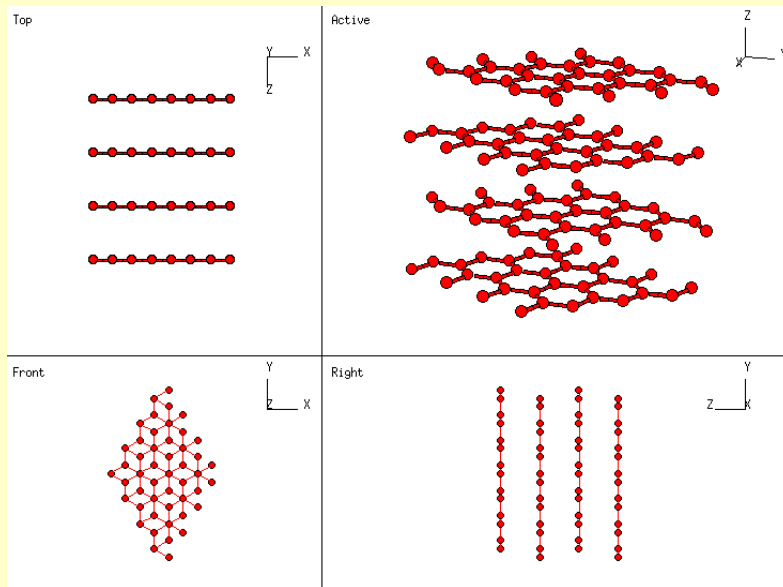

p, T Diagram of Carbon

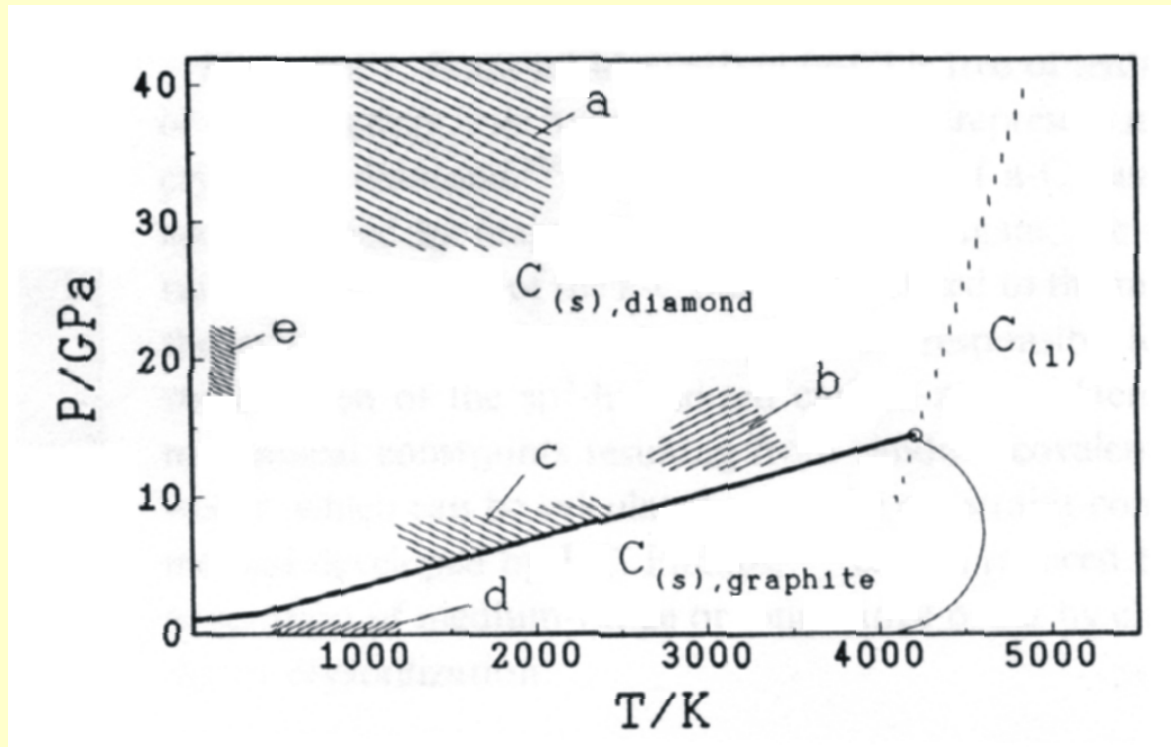

- a – shock wave production of diamond**
- b – high-temperature, high-pressure synthesis of diamond**
- c – catalytic region for diamond formation**
- d – CVD diamond**
- e – transformation of C₆₀ into diamond**

The activation energy required for a sp^2 3-coordinate to a sp^3 4-coordinate structural transformation is very high, so requires extreme conditions

Ways of getting round the difficulty

◆ **Catalyst: transition metals (graphite is dissolved in molten metal: Fe, Ni, Co, 6 GPa, 1000 °C), alloys (Nb-Cu), $CaCO_3$, hydroxides, sulfates, P (7.7 GPa, 2200 °C, 10 min),**

◆ **Squeezing (uniaxial not hydrostatic pressure), no heating, buckyball carbons are already intermediate between sp^{2-3} .**

C_{60} , diamond anvil, 25 GPa instantaneous transformation to bulk crystalline diamond, highly efficient process, fast kinetics

◆ **Carbon onions, electron irradiation of graphite, concentric spherical graphite layers, spacing decreases from 3.4 Å to 2.2 Å in the onion center, 100 GPa, 200 keV beam, in several hours, pressureless conversion to diamond**

◆ **Using CH_4/H_2 microwave discharges to create reactive atomic carbon whose valencies are more-or-less free to form sp^3 diamond, atomic hydrogen saturates the dangling bonds, dissolves soot faster than diamond, a route for making diamond films, 50 μm**

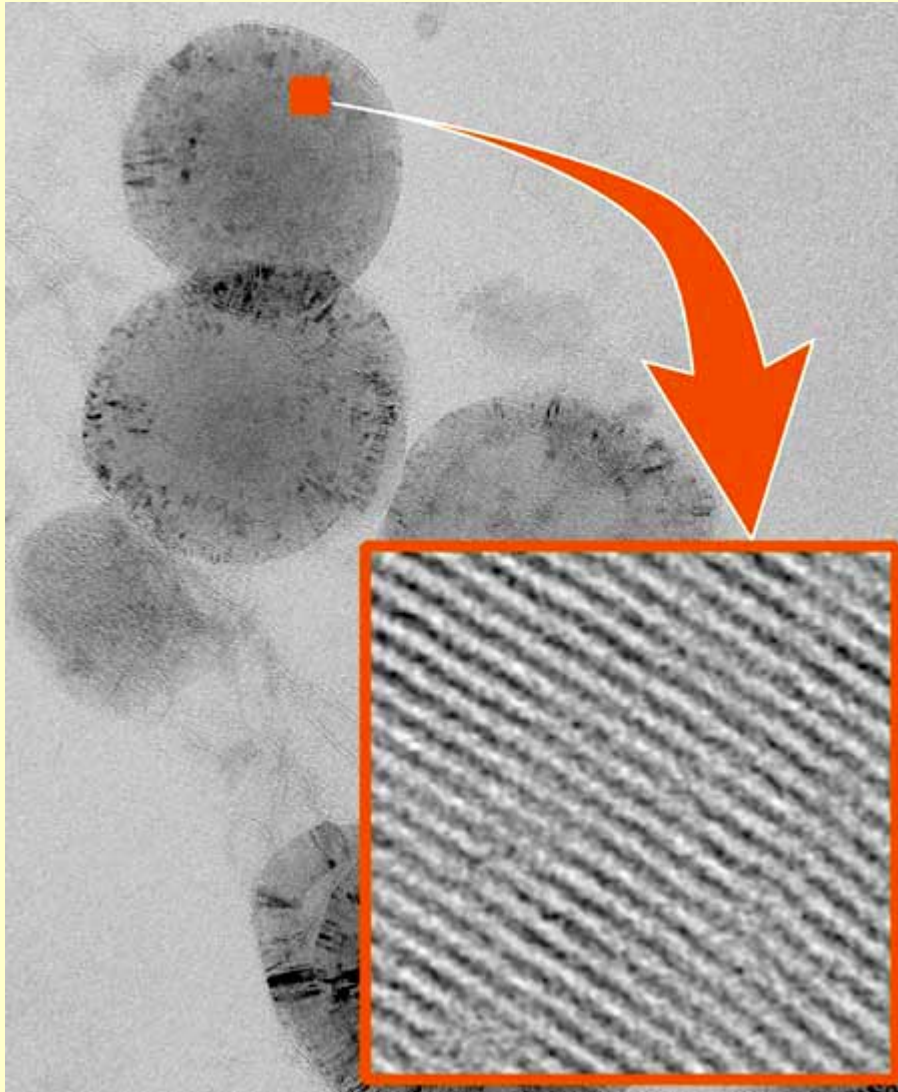

Graphite

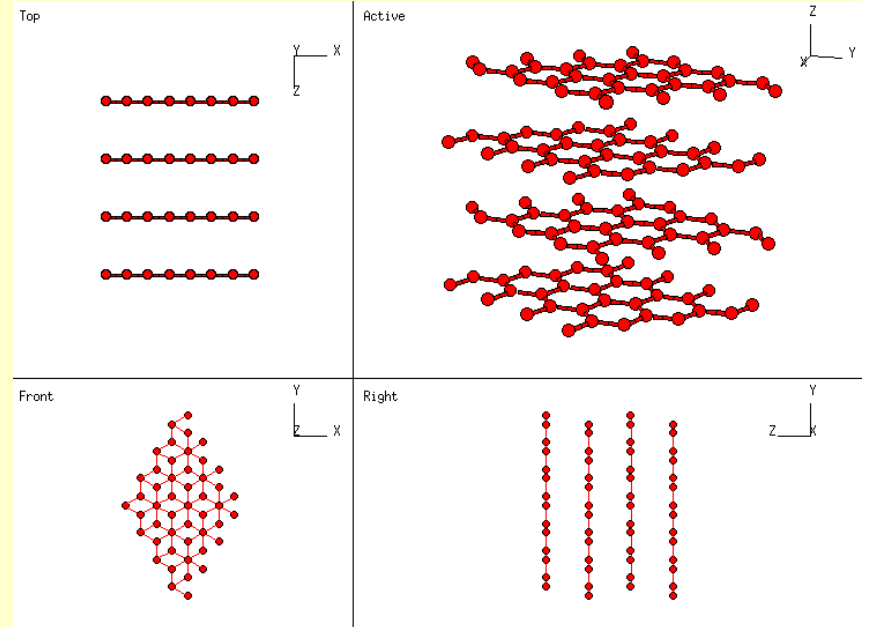

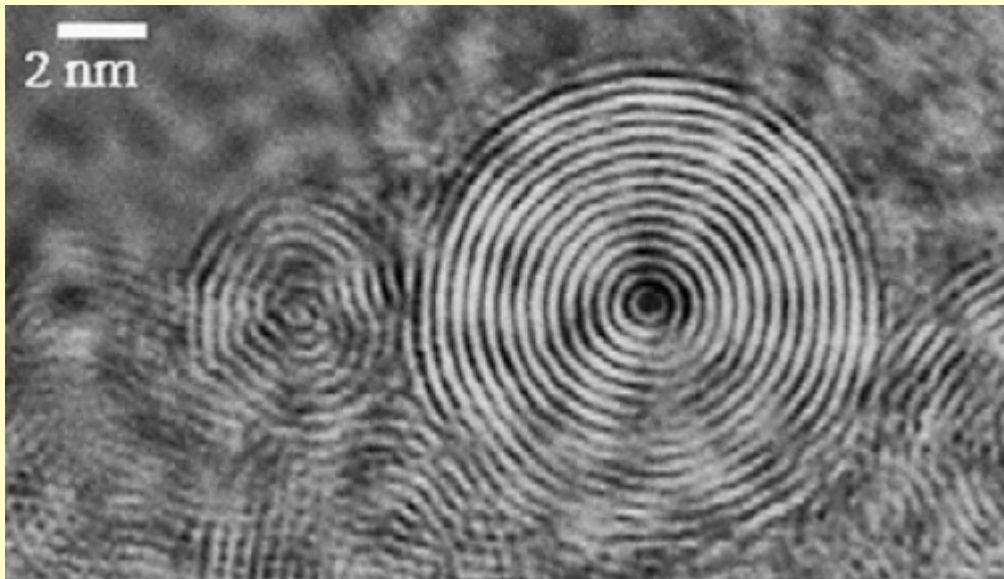

Carbon onions

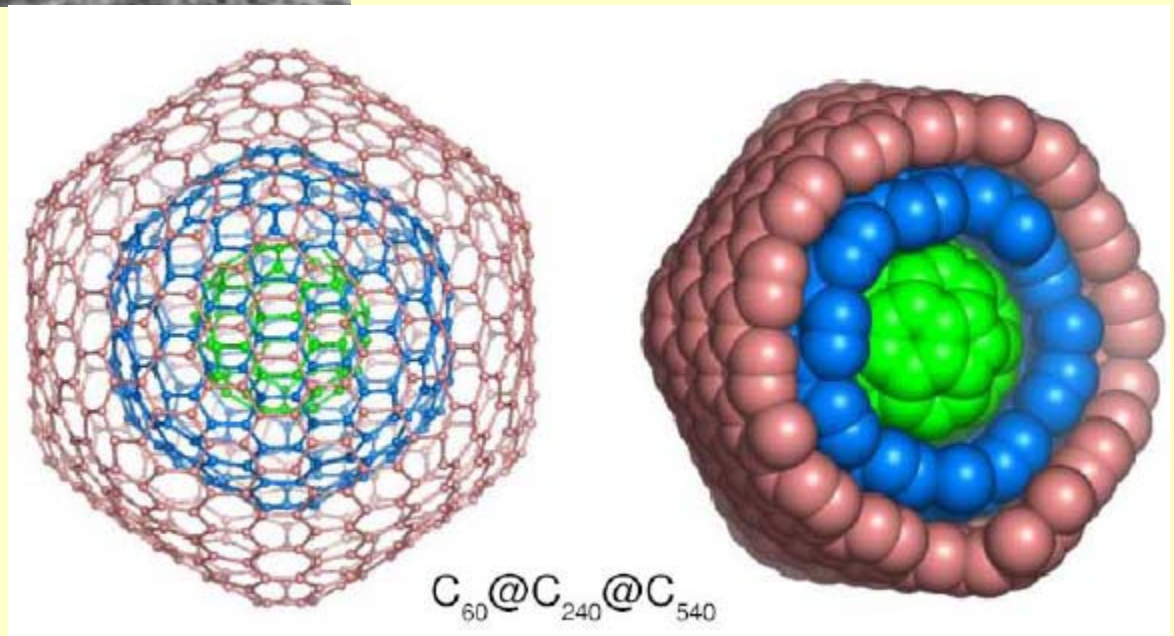

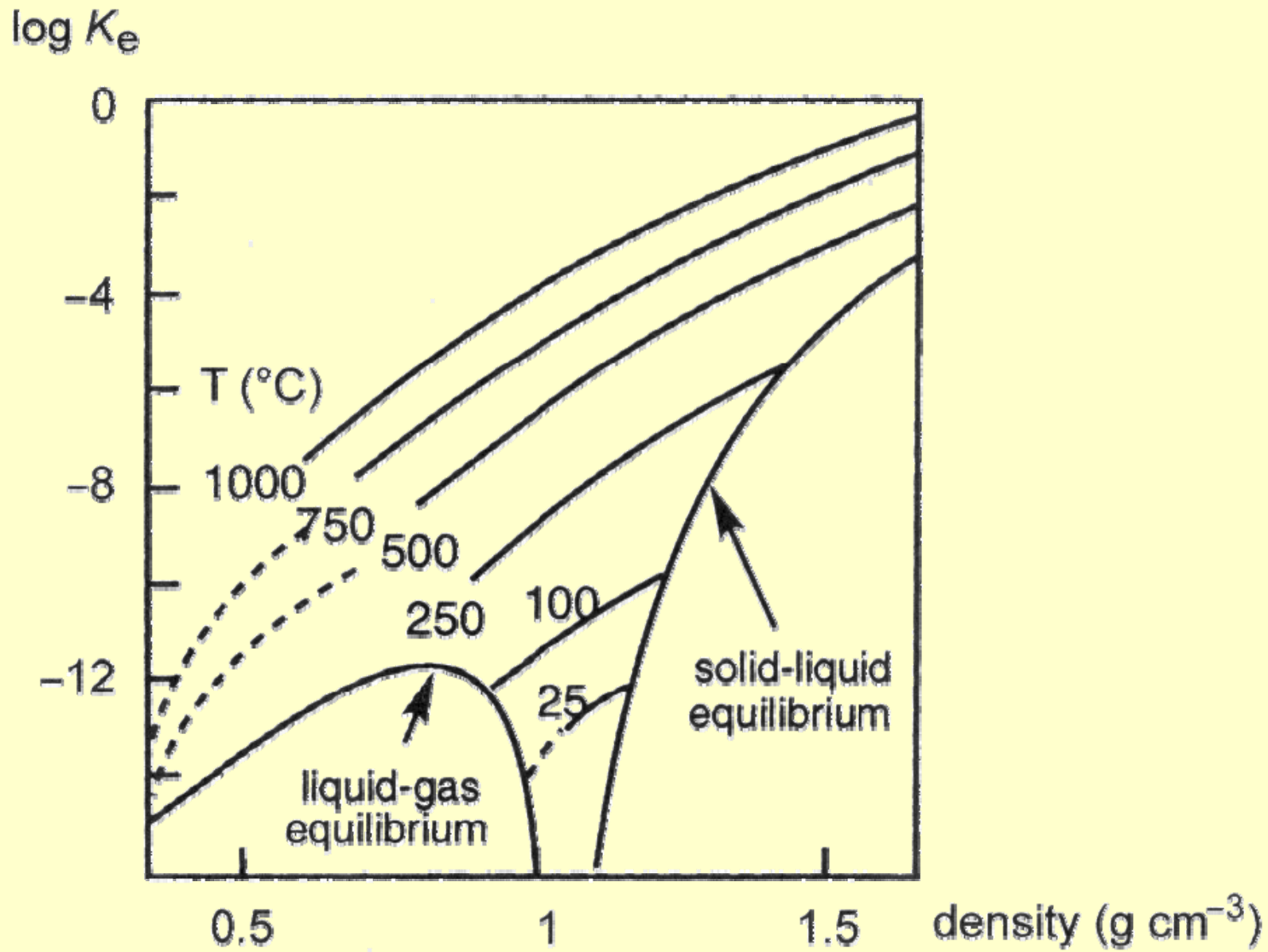

Organic molecule theory of diamond cleavage

The jeweler's chisel if placed correctly on a diamond, with a well oriented blow, always cause cleavage along {111} greater than 90% of the time, imagine the cost of a mistake with a large crystal

The number of bonds broken per unit area (that is, surface energies) for different planes does not explain the observations of preferential {111} cleavage!!!

Diamond viewed in terms of layers of polycondensed cyclohexane rings with axial bonds between layers and equatorial bonds within layers

Unfavorable axial-axial C-C bond interactions at 2.51 Å versus equatorial-equatorial at 2.96 Å

Model compounds like cis-decalin versus trans-decaline comprised of two fused cyclohexane rings trans-decalin is 11-12 kJmol⁻¹ more stable because cis-strain cannot be relieved by bond rotation as in cyclohexane itself, cis can only isomerize to trans by bond cleavage followed by recombination, hence origin of the high activation energy for the cis-to-trans isomerization of decalin.

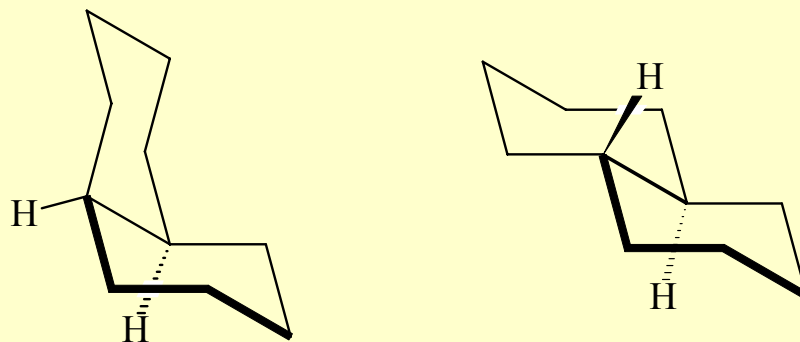

A breaking molecule theory: axial-axial unfavorable interactions cause the mechanical energy of the jeweler's chisel to be funneled into preferential breakage of an axial C-C bond This then induces a kind of domino effect whereby the adjacent axial C-C bonds break and C-C bonds throughout the entire {111} plane are severed

Topochemical 3D Polymerization of C_{60} under High P and T

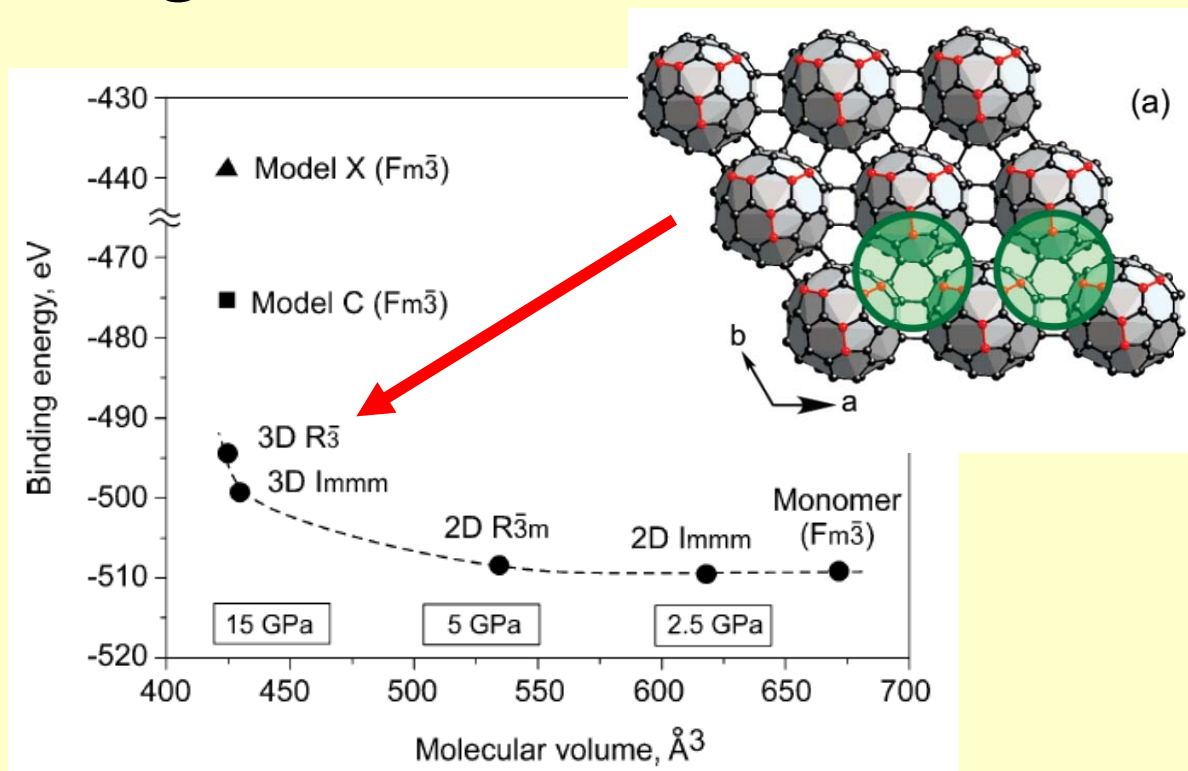
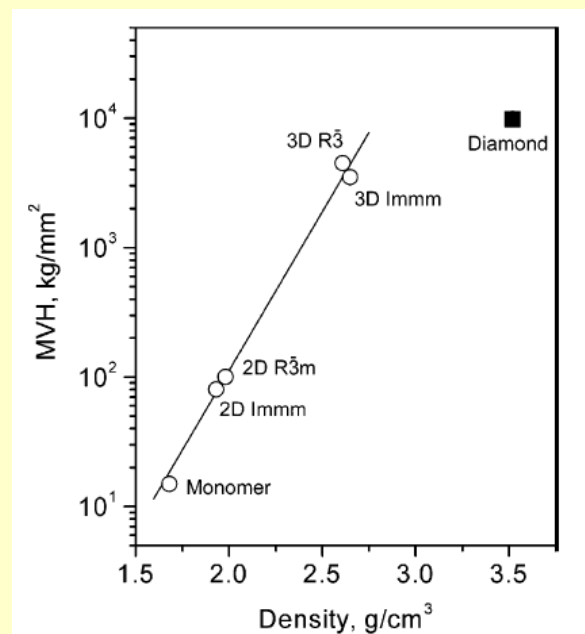

Micro-Vickers hardness (MVH)

Polymerization of C₆₀

C ₆₀ phase	no. of covalently bonded neighbors	MVH, kg/mm ²	d_{calcd} g/cm ³	d_{obs} g/cm ³
monomer	0	15	1.684	1.68
2D <i>Immm</i>	4	80	1.936	1.93
2D $R\bar{3}m$	6	100	2.004	1.98
3D <i>Immm</i>	8	3,500	2.78	2.65
3D $R\bar{3}$	12	4,500	2.81	2.61
Diamond ^a		10,000	3.52	
c-BN ^a		5,000		

- **Electrical conductivity of semiconductors increases with T. The change of conductivity with T is one way of measuring the band gap.**
- **Conductivity also increases with P, because atoms are pushed closer together.**
- **All elements eventually adopt metallic structures at high P.**
- **The interior of Jupiter is **thought** to contain metallic hydrogen!**