

Vakuové ventily

Dělení podle různých principů

Podle funkčnosti

- oddělovací
- napouštěcí
- zavzdušňovací
- omezení čerpací rychlosti

Ovladání

- ruční
- pneumatický
- elektromagnetický

Oblast použití

- hrubé vakuum
- HV vakuum
- UHV, XHV vakuum

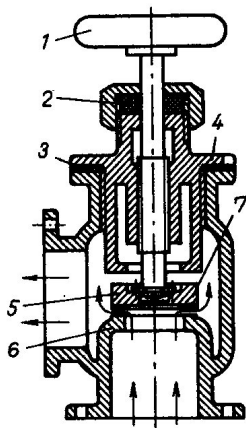

Obr. 6.27. Ventil s talířkem přitlačovaným šroubem

1 – rukojeť; 2 – těsnění; 3 – těsnící kroužek; 4 – horní příruba; 5 – talířek; 6 – dolní příruba; 7 – těsnění talířku

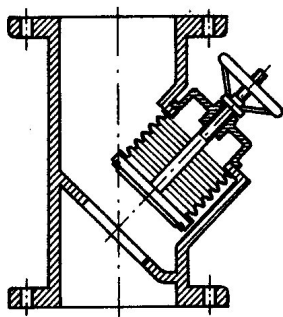

Obr. 6.28. Ventil těsněný vlnovcem

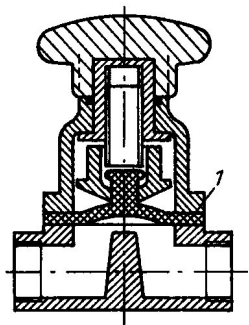

Obr. 6.32. Ventil pro nízké vakuum
s membránovým těsněním (firma Leybold)

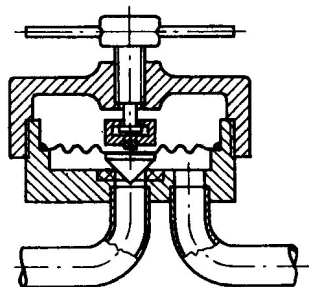

Obr. 6.33. Řez ventilu s kuželovým čepem
a membránovým těsněním pro ultravysoké
vakuum

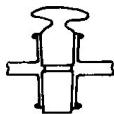

(a)

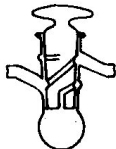

(b)

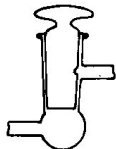

(c)

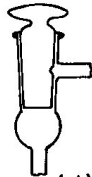

(d)

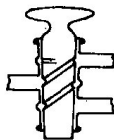

(e)

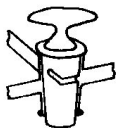

(f)

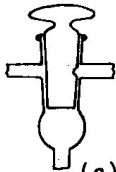

(g)

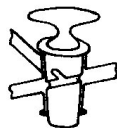

(h)

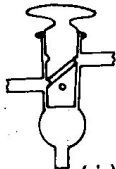

(i)



(j)

a)

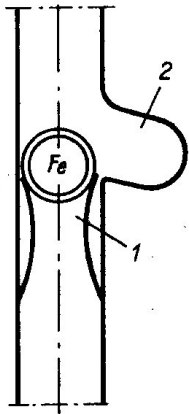

b)

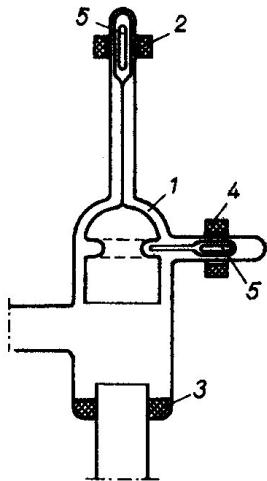
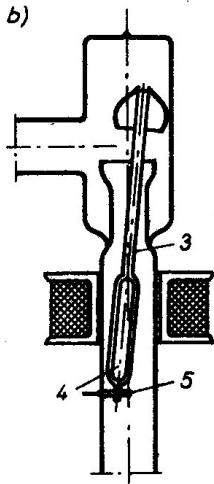

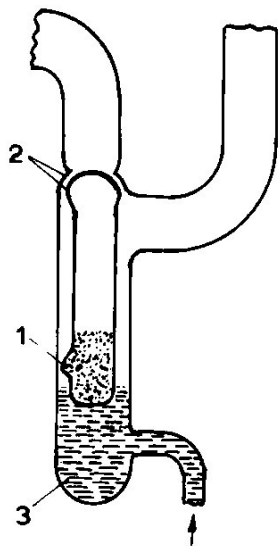

(a)

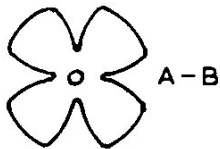
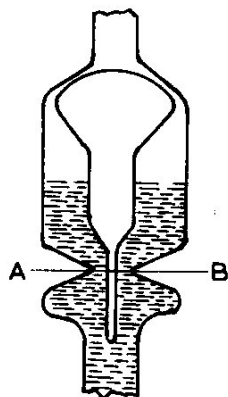

(b)

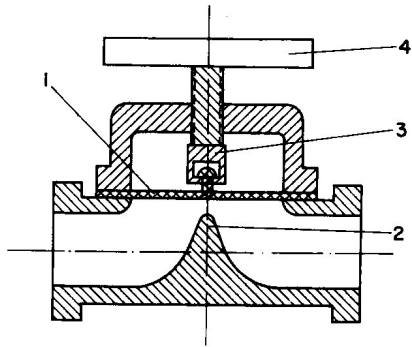
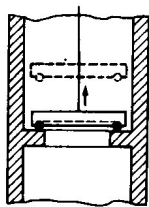
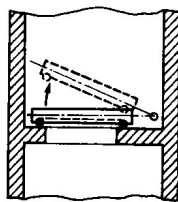

Fig. 7.61 Diaphragm valve.



(a)



(b)

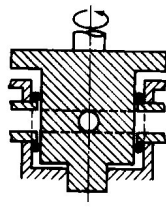

(c)

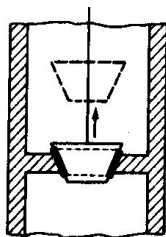

(d)

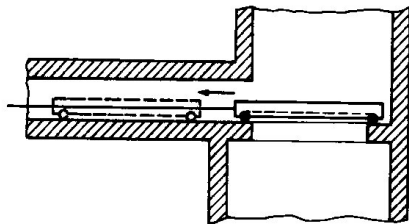

(e)

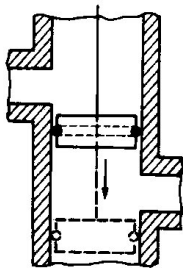

(f)

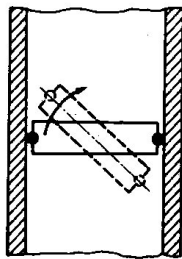

(g)

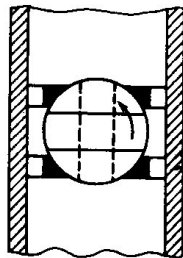

(h)

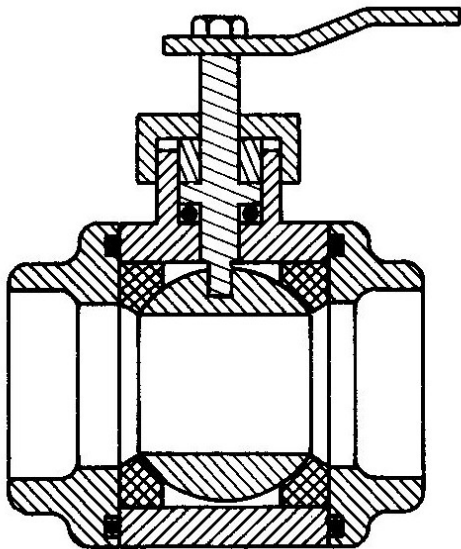

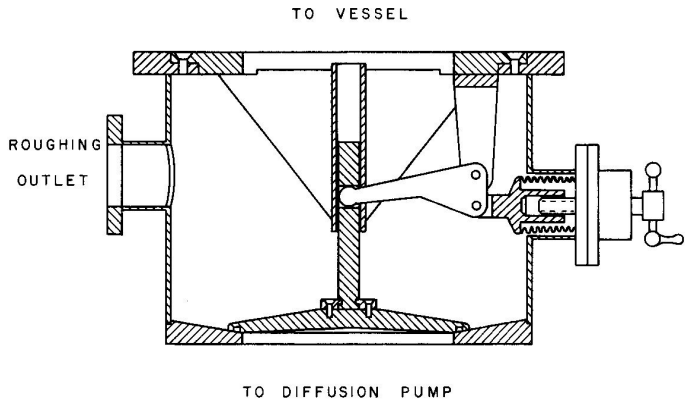

Fig. 2.29. Poppet valve.

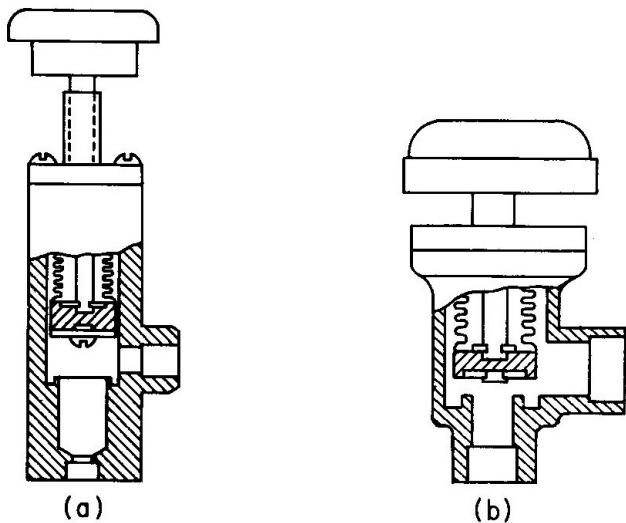

Fig. 2.28. Angle valves. (a) Machined from bar stock. (b) Cast.

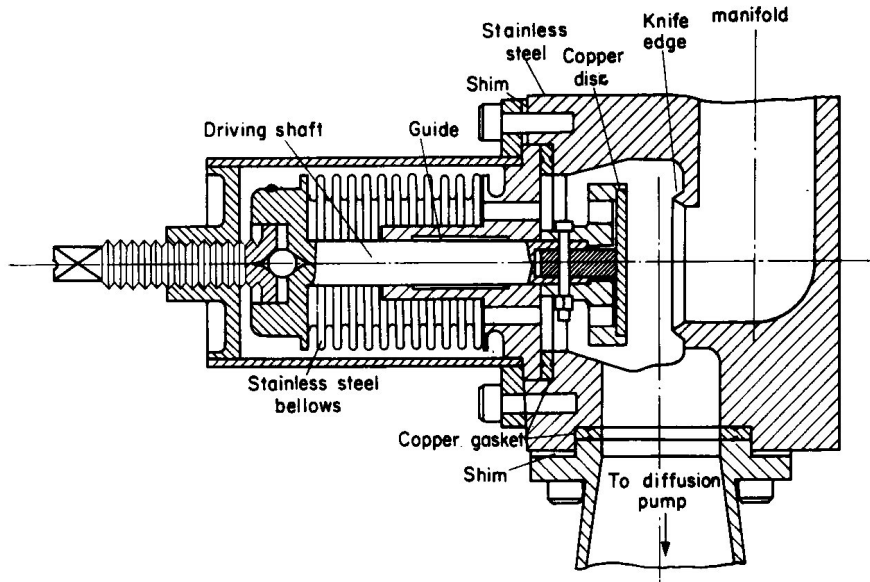

Fig. 7.65 Ultra-high vacuum valve. After Baker (1962).

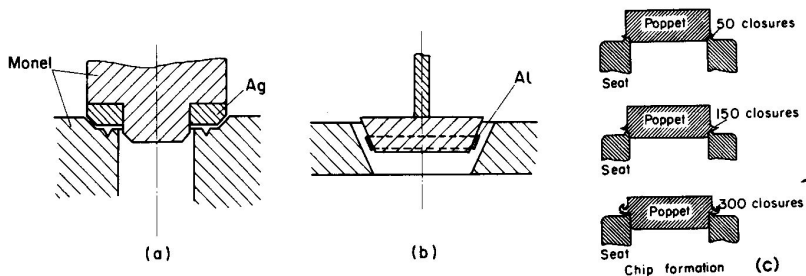
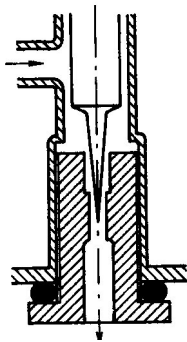
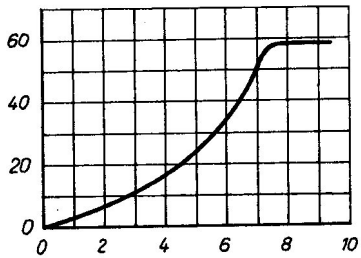

Fig. 7.63 Closing systems of all-metal valves; (a) with flat silver ring (Bills and Allen, 1955); (b) with aluminum conical ring (Kienel and Lorenz, 1960); (c) with copper poppet (Parker and Mark, 1961).



$I_N (\text{cm}^3(\text{NTP})\text{s}^{-1})$



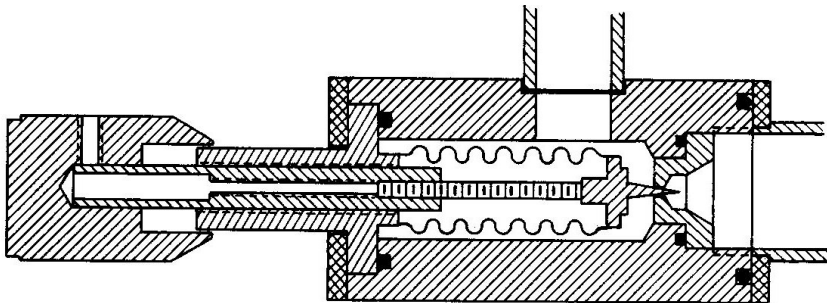

Fig. 2.31. Needle valve.

- deskové ventily - při otevírání dif.tlak menší než ~ 30 mbar
- ventily s kovovým těsněním - omezený počet cyklů
- jehlové ventily - nedotahovat silou
- zábrusové ventily - dobře namazat

Elektrické průchodky

Vakuum v rozsahu tlaků 1-5000 Pa je velmi špatný elektrický izolant.
Průchodky vybíráme podle:

- napětí
- proudu
- frekvence

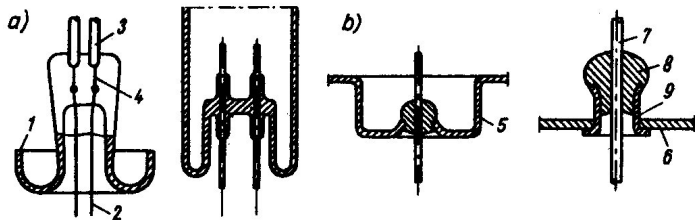

Obr. 6.47. Elektrické průchodky pro slabé proudy

a) vodič z plášťového nebo platinovaného drátku zataveného ve skle, b) prûtav skleněnou perličkou zatavenou do otvoru v kovové stěně

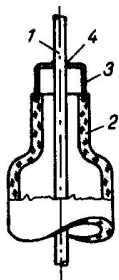

Obr. 6.48. Silnoproudá průchodka skleněnou trubicí
 1 – průtav; 2 – sklo; 3 – kovarová čepička; 4 – pájka

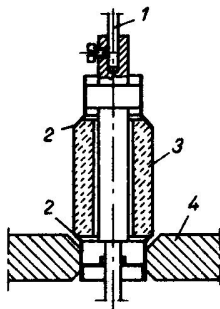

Obr. 6.49. Silnoproudá průchodka kovovou stěnou s keramickým izolátorem
 1 – přívod; 2 – spoj kovu s keramikou; 3 – keramika; 4 – stěna vakuového systému

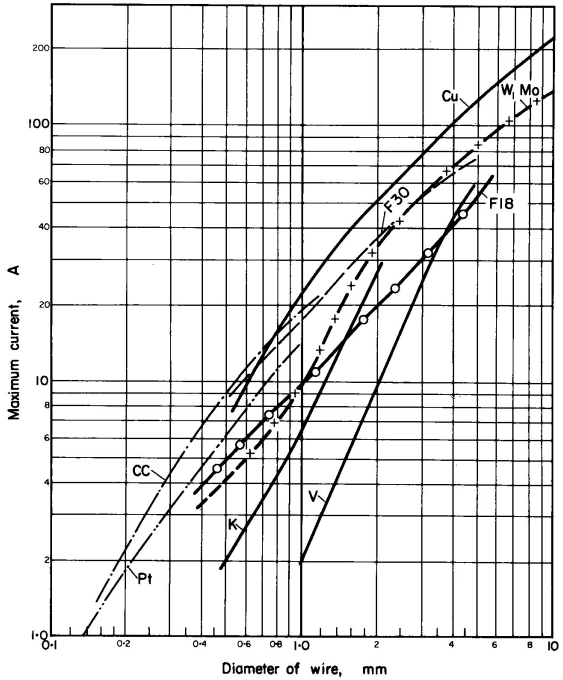

Přenos rotace do vakua

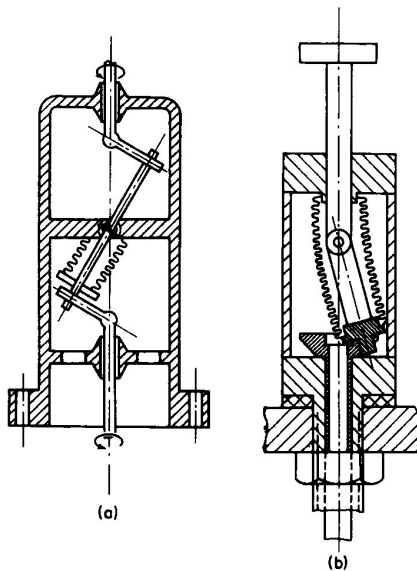

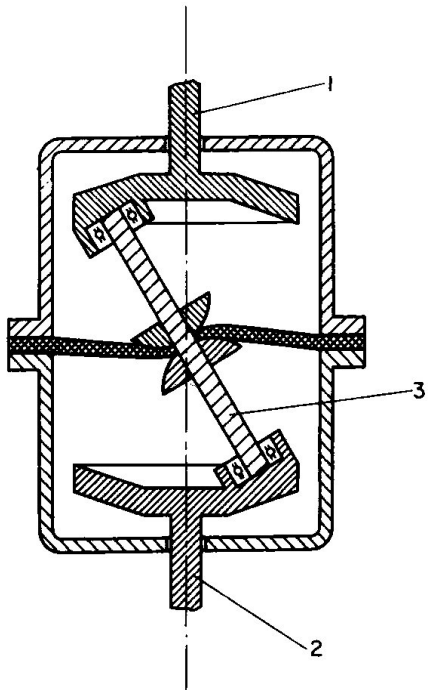

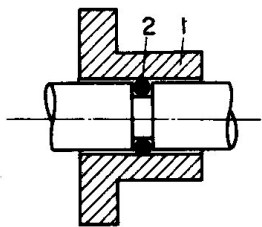

(a)

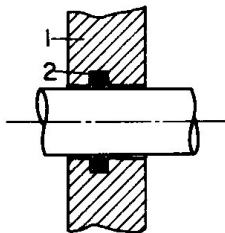

(b)

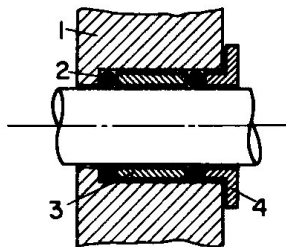
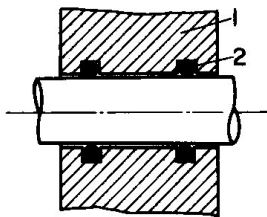

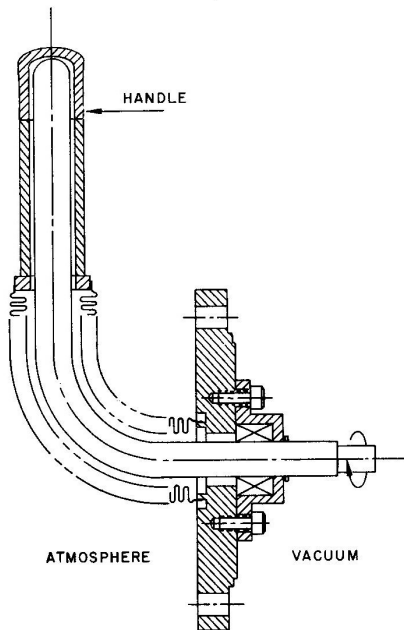

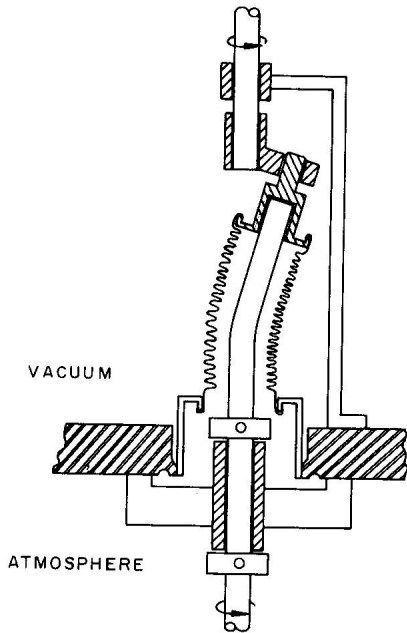

Ohebné spoje

- připojení primárních vývěv
 - kovové vlnovce
 - bellows - změna délky při změně tlaku
 - flexible metal hose
 - tlustostěnné hadice
 - hadice s kovovou spirálou