

NEURÁLNÍ A BUNĚČNÉ PROCESY SMYSLOVÉ TRANSDUKCE – JAK SMYSLOVÉ PODNĚTY VSTUPUJÍ DO NERVOVÉHO SYSTÉMU.

A CO UŽITEČNÉHO Z TOHO PLYNE?



Upozornění na:

- to, co se děje na membránách smyslových buněk a jak mohou smyslové podněty zasáhnout do metabolismu buněk.
- Paralely se známými signálními drahami diference, imunity, apoptózy...
- Společně využívané „vyzkoušené“ funkce a vztah mezi studiem chování, smyslů a buněčné komunikace

Schopnost organismů rozpoznávat i nepatrné změny vnějšího prostředí a reagovat na ně v případě ohrožení je jednou z nejdůležitějších podmínek zachování života.

Selekční tlak byl natolik silný, že schopnosti receptorů jsou často na samé hranici fyzikálních možností. Jednotlivé fotony, jednotlivé molekuly, pohyby nanometrových amplitud, nesmírně slabé elektromagnetické pole fascinují fyziology.

Výzkum molekulární podstaty transdukčních mechanismů chemických signálů, mechanických podnětů, ale i např. infračervené detekce, elektrických polí nebo magnetického pole jsou výzvami fyziologii s velkým potenciálem.

Všech 5 pohromadě



Vstup do NS, potřeba rychlé motorická reakce, kontakt s vědomím.

Kontakt se světem



Předpoklad: některé buňky dokážou reagovat na různé formy energie (chemické, mechanické, elektromagnetické). Metabolická reakce se pak zobrazí jako změna elektrického membránového napětí.

Hranice smyslového a ne-smyslového signálu

VĚDOMÍ

Kůra telencefala

PODVĚDOMÍ
Reflexní,
automatické řízení

Motorický NS

Vegetativní NS

Hormonální S

Buněčná recepce a komunikace



Vnější podněty:
zvuky, vůně...

Vnitřní podněty:
hladina Glc,
apoptotický signál,
růstový f. ...

VĚDOMÍ

Kůra telencefala

PODVĚDOMÍ
Reflexní,
automatické řízení

Motorický NS

Vegetativní NS

Hormonální S

Buněčná recepce a komunikace

Buněčné „oči“ a „uši“

Vnější podněty:
zvuky, vůně...

Vnitřní podněty:
hladina Glc,
apoptotický signál,
tah v membráně...



Klasické smysly propojené s kůrou, mechanismy ale stejné

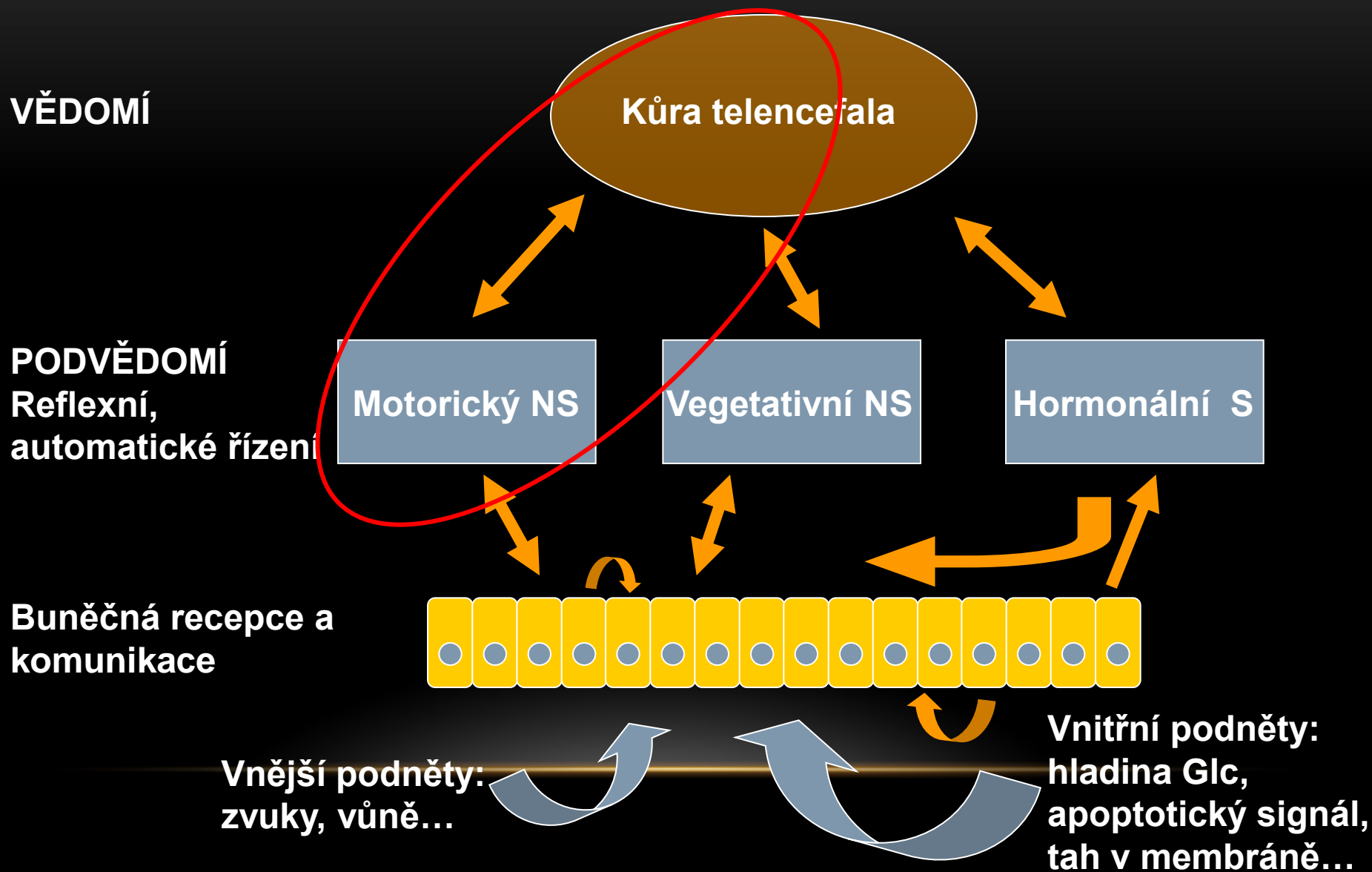

Kanály v molekulární fyziologii smyslů

- Nervový systém vsadil na elektricky předávané informace.
- Kanály jsou odpovědné za regulaci membránového napětí a tedy klíčové pro vznik a přenášení nervových signálů.
- Nervový systém tedy „vidí“ jen to, co změní kanálovou propustnost.
- Pro vstup do NS podstatné to, co se děje mezi receptory a kanály

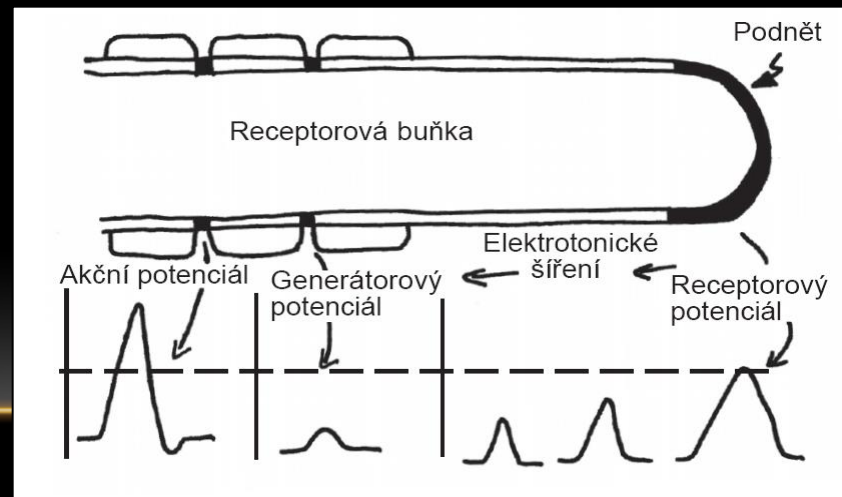

Klíčová otázka: co se děje mezi receptory a kanály

Ionotropní
transdukce – receptor přímo na kanálu

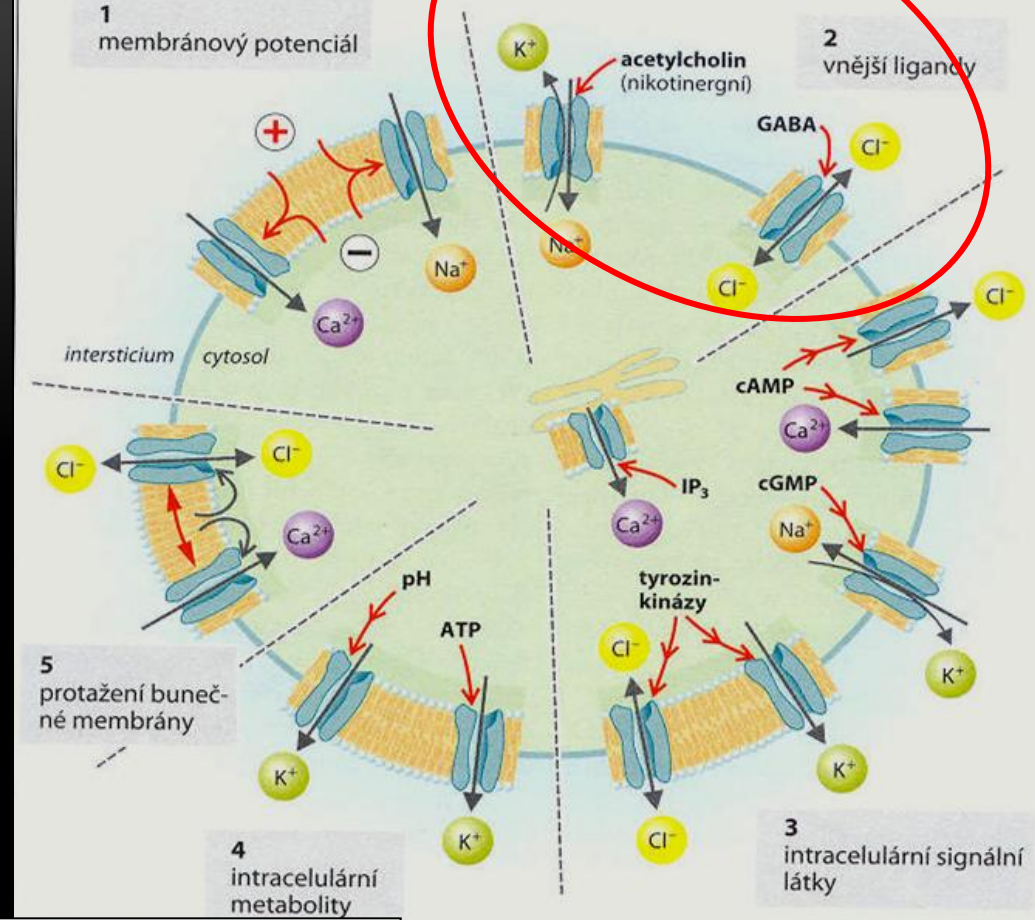

TABLE 12.3 Ionotropic and metabotropic receptors: Structural, functional, and mechanistic differences

Characteristic	Ionotropic receptors	Metabotropic receptors
Receptor molecule	Ligand-gated channel receptor	G protein-coupled receptor
Molecular structure	Five subunits around an ion channel	Protein with seven transmembrane segments; no channel
Molecular action	Open ion channel	Activate G protein; metabolic cascade
Second messenger	No	Yes (usually)
Gating of ion channels	Direct	Indirect (or none)
Type of synaptic effect	Fast EPSP or IPSP	Slow PSPs; modulatory changes (in channel properties, cell metabolism, or gene expression)

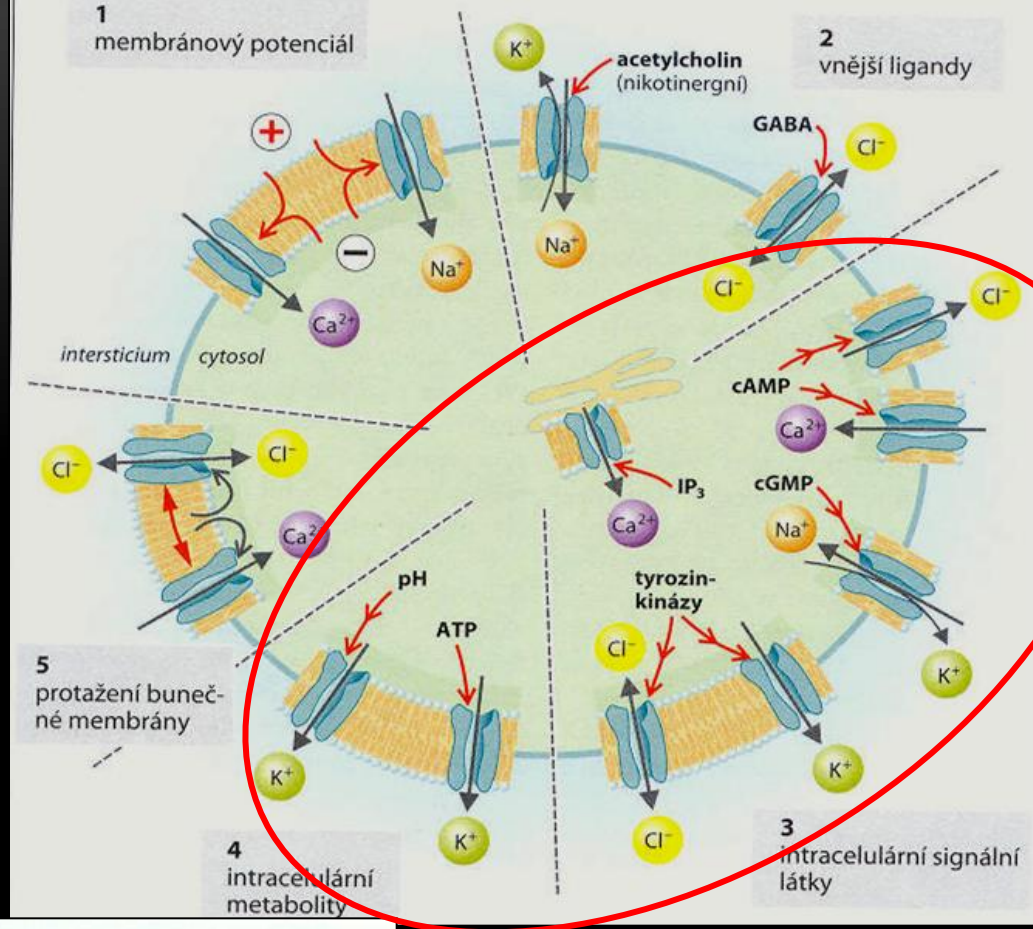
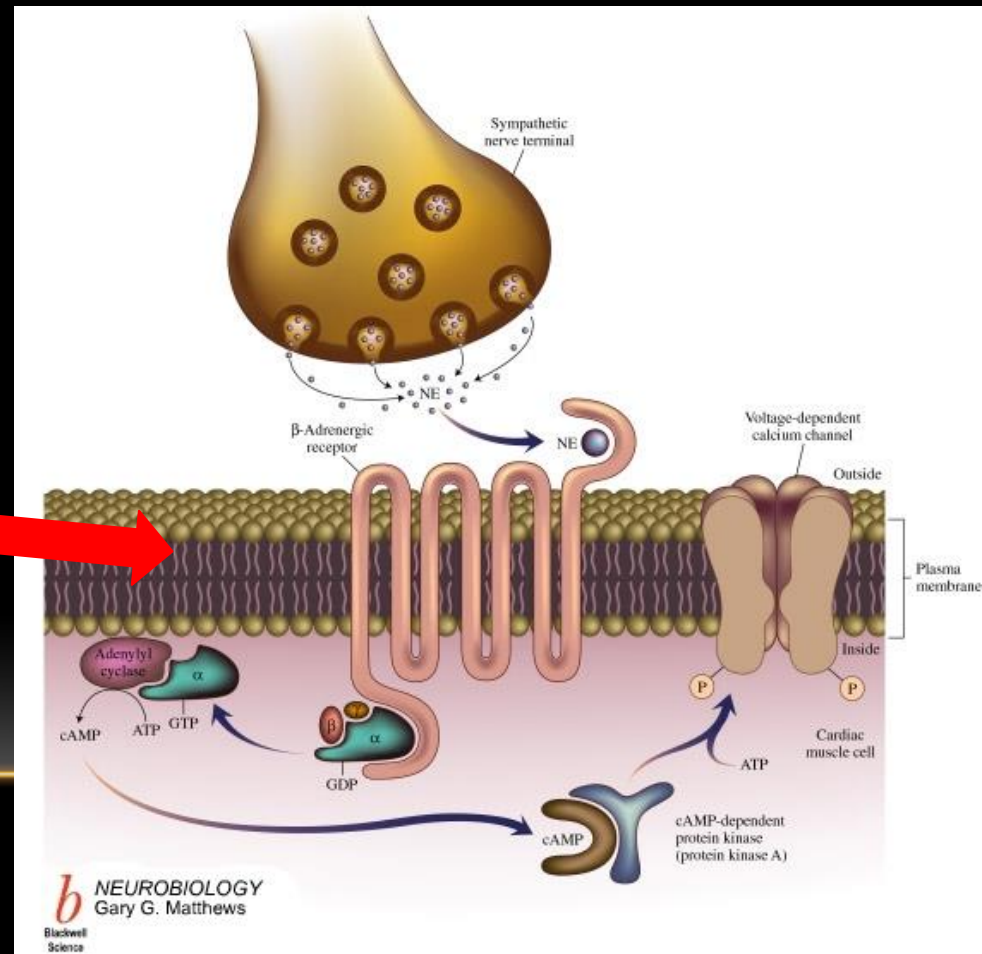
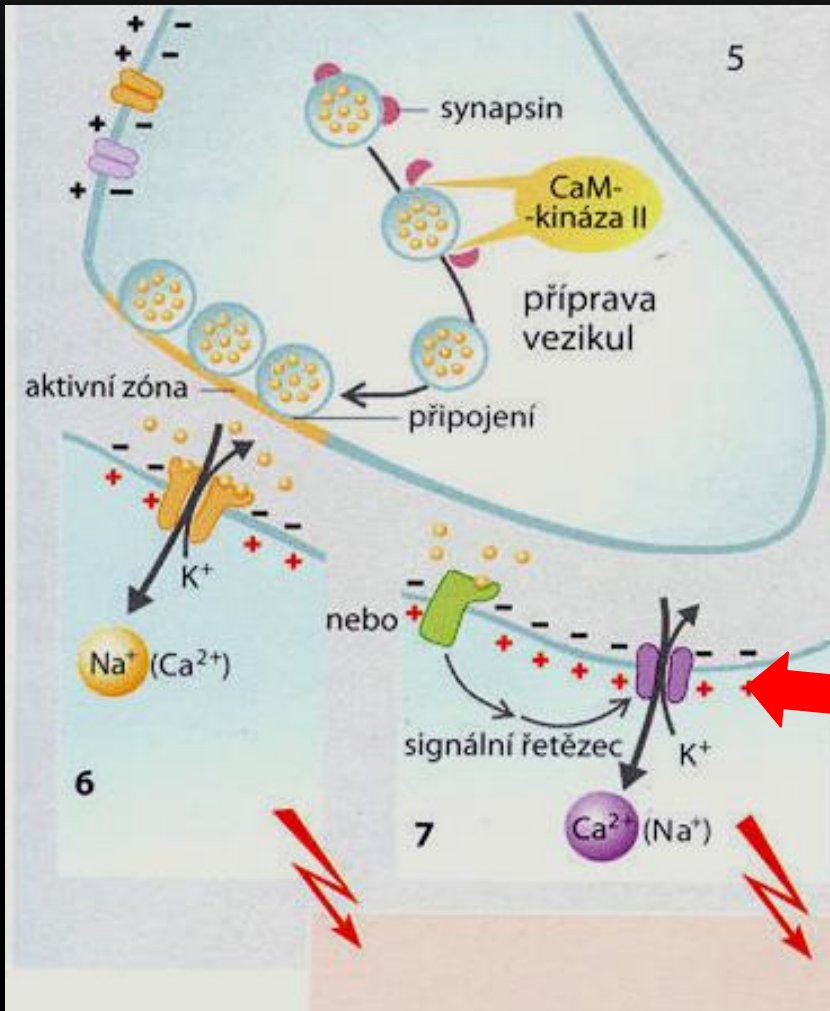

TABLE 12.3 Ionotropic and metabotropic receptors: Structural, functional, and mechanistic differences

Characteristic	Ionotropic receptors	Metabotropic receptors
Receptor molecule	Ligand-gated channel receptor	G protein-coupled receptor
Molecular structure	Five subunits around an ion channel	Protein with seven transmembrane segments; no channel
Molecular action	Open ion channel	Activate G protein; metabolic cascade
Second messenger	No	Yes (usually)
Gating of ion channels	Direct	Indirect (or none)
Type of synaptic effect	Fast EPSP or IPSP	Slow PSPs; modulatory changes (in channel properties, cell metabolism, or gene expression)

Metabotropní transdukce

Ionotronní a Metabotropní transdukce



Kanály – prostředek pasivního transportu udržování integrity buňky a komunikace

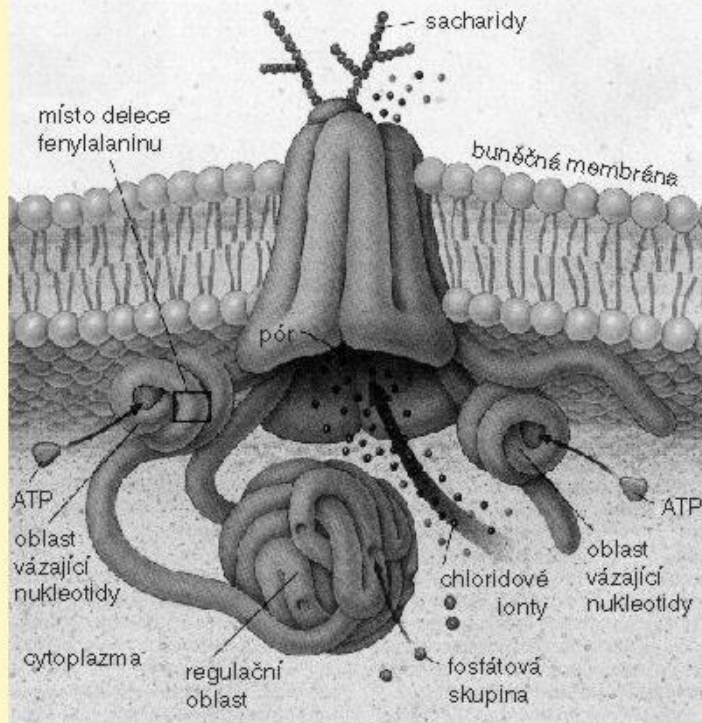

Po ukotvení v membráně se protein CFTR složitě přizpůsobuje – vytváří kanálky, kterými mohou přes membránu proudit chloridové ionty. V cytoplazmatické části proteinu jsou tři regulační oblasti, které se podílejí na uzavírání a otevírání póru. Kanálek se otevře jedině tehdy, když se na CFTR navážou dvě molekuly ATP a zároveň je fosforylována třetí regulační oblast. U mutovaného proteinu je jedna z oblastí vázajících ATP intaktní a membránový kanálek se neotevírá.

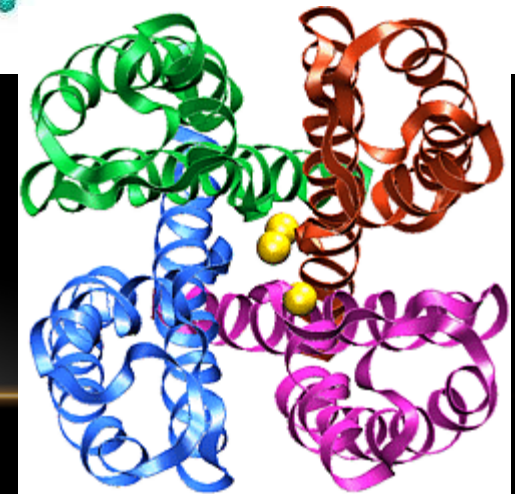
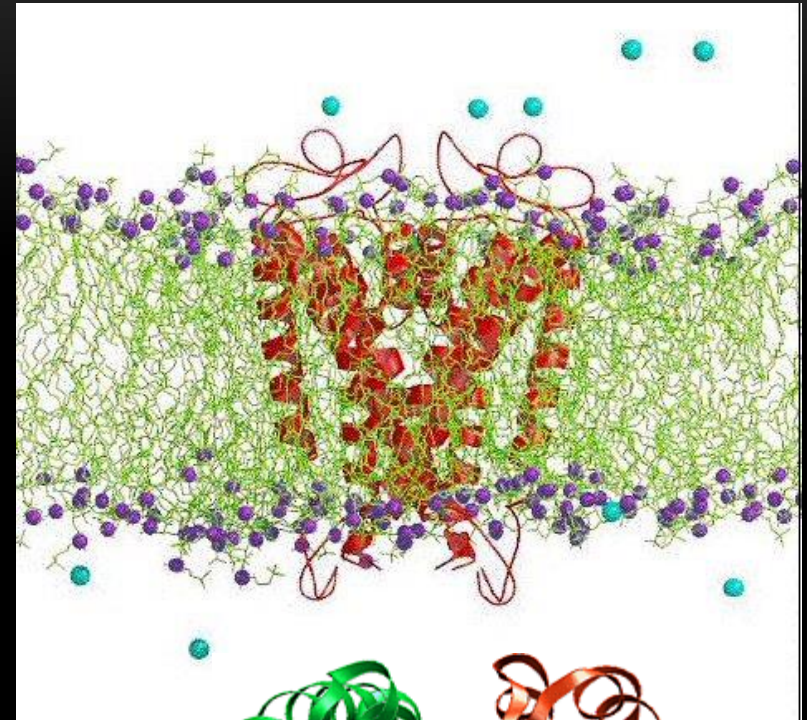

Už jste se mimo NS potkali s kanály? Do řetězců buněčné komunikace patří.

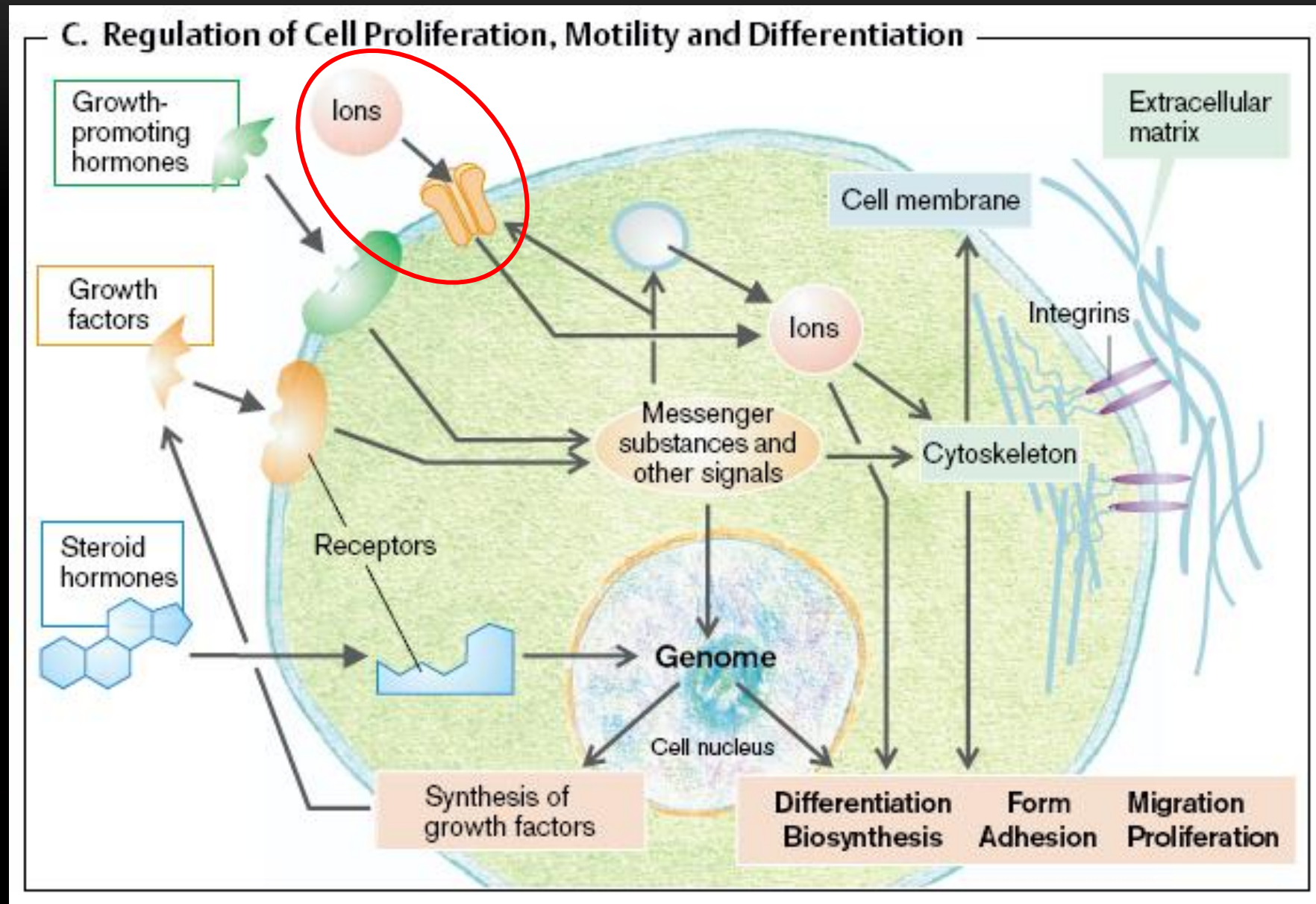

Už jste se mimo NS potkali s kanály?

Vodní hospodářství je otázkou řízené propustnosti membrán.

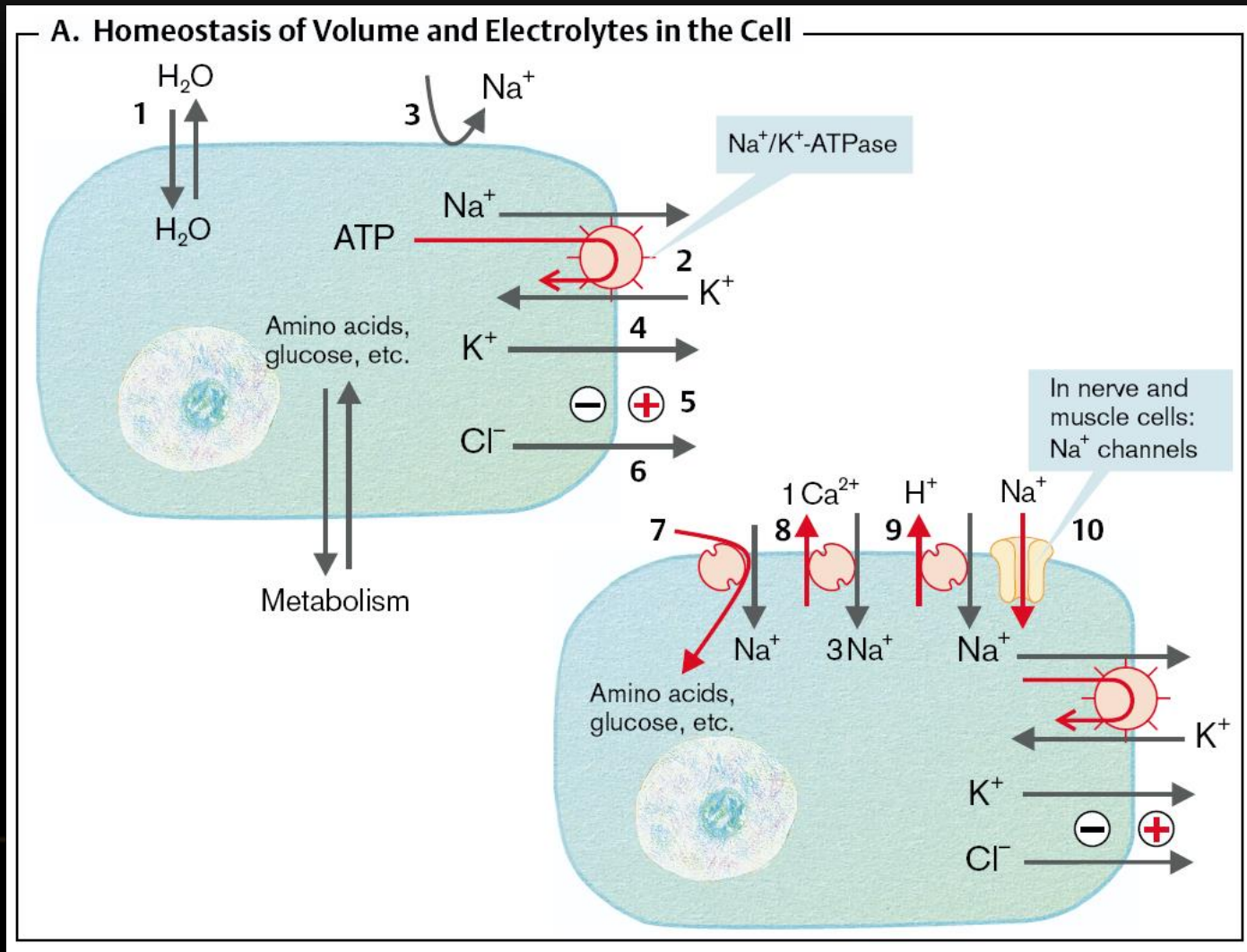

Už jste se mimo NS potkali s kanály?

IP₃ a Ca signál

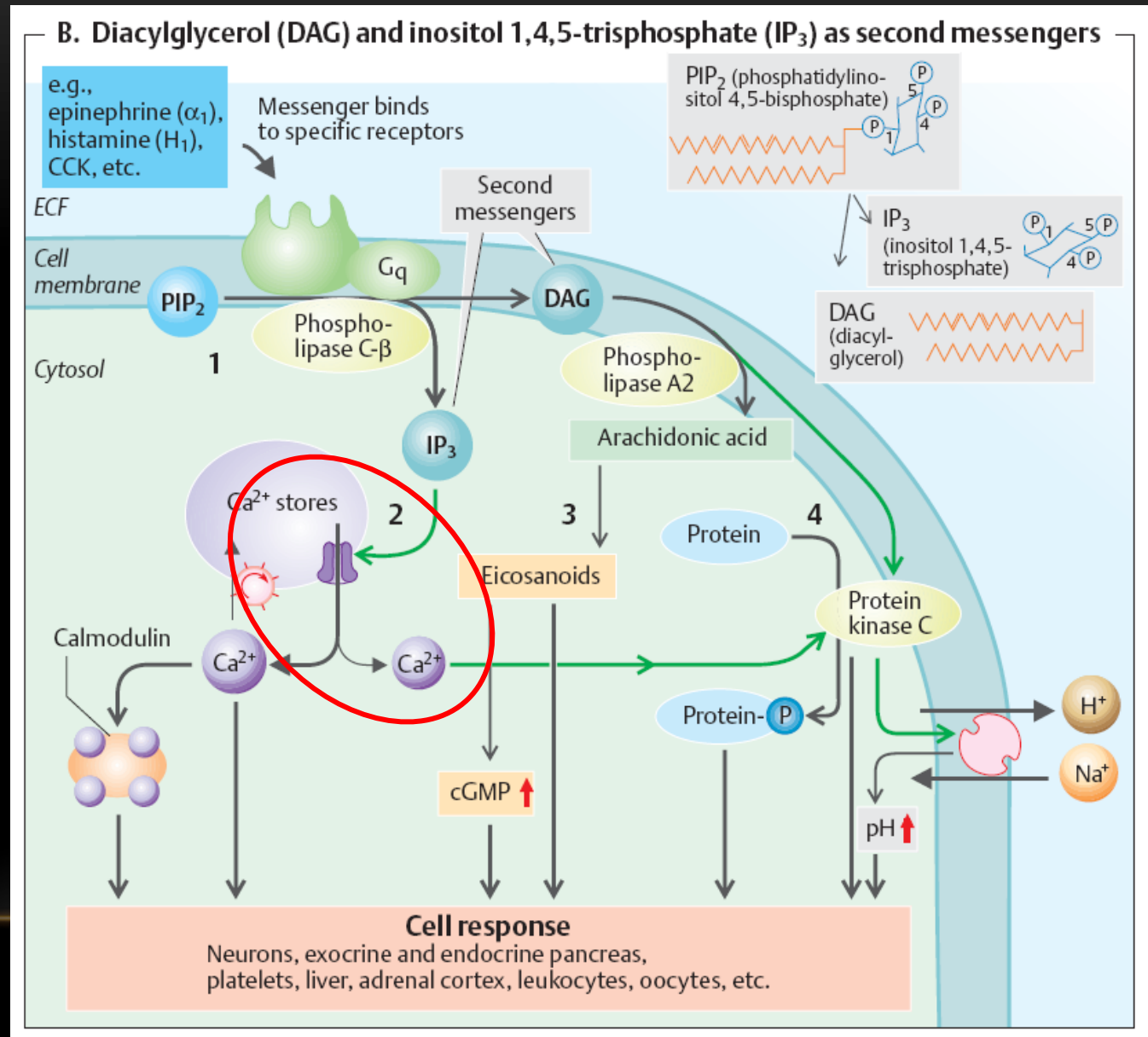

Už jste se mimo NS potkali s kanály?

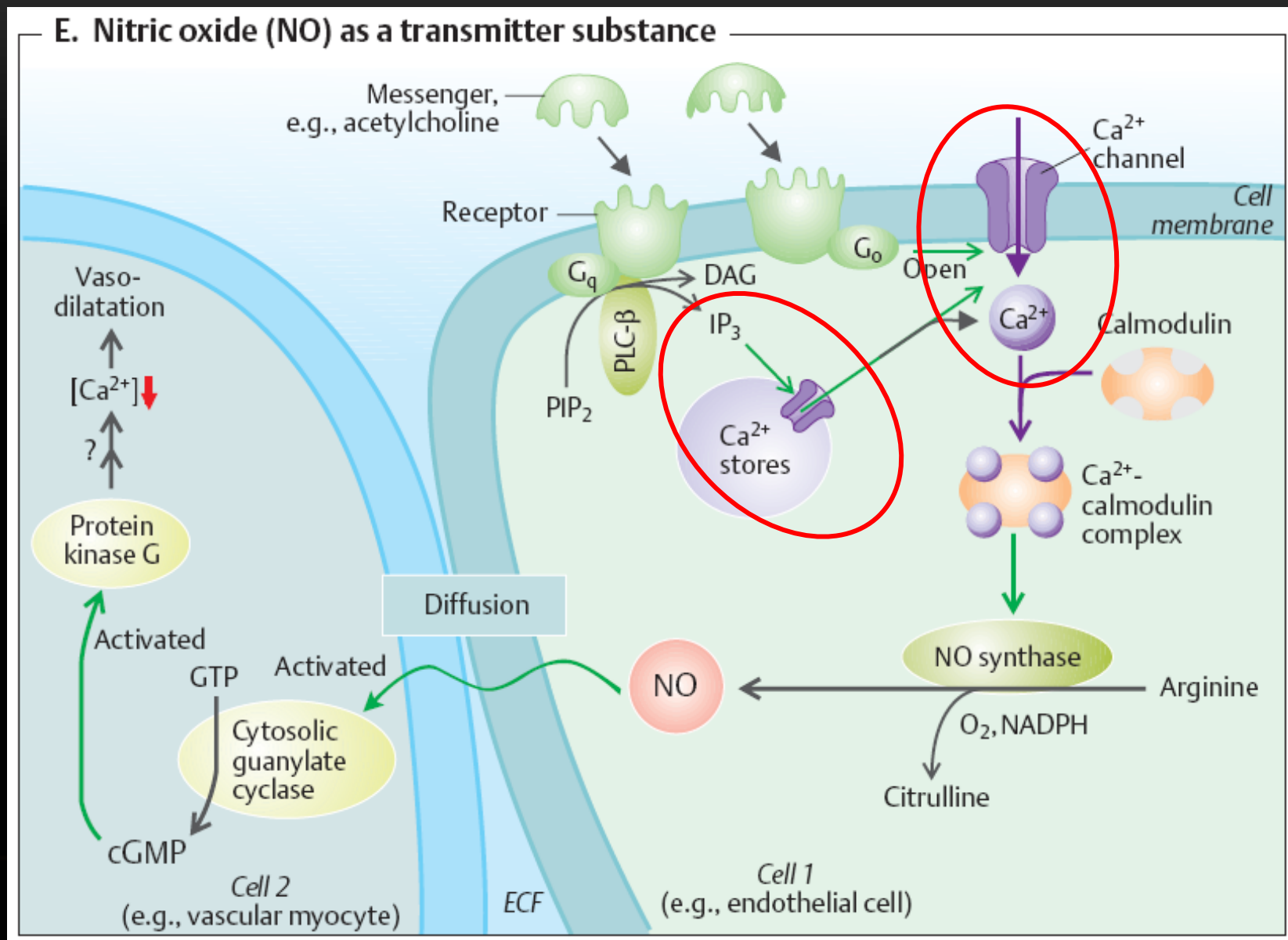

Už jste se mimo NS potkali s kanály?

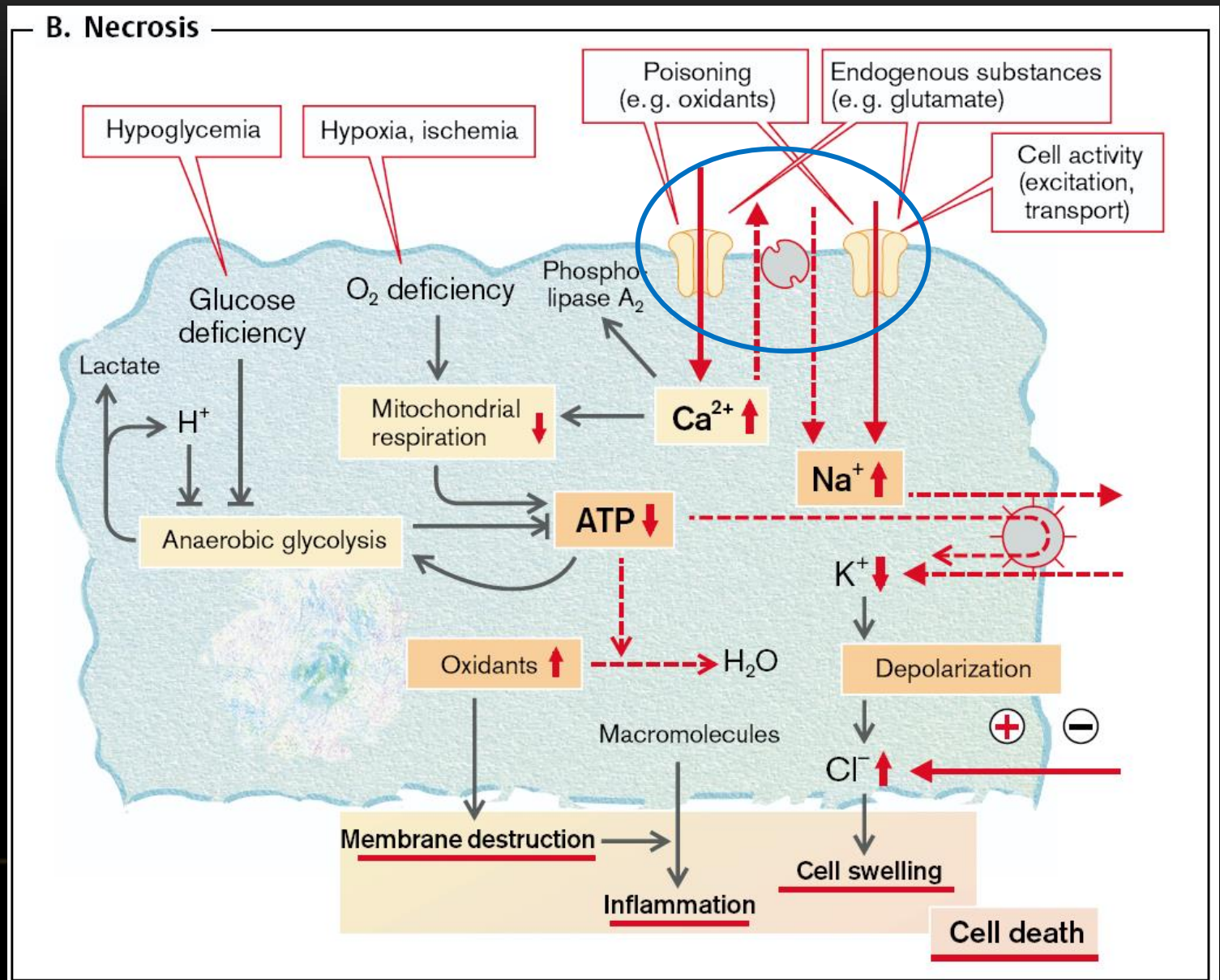

Už jste se mimo NS potkali s kanály?

A. Triggering and Development of Apoptosis

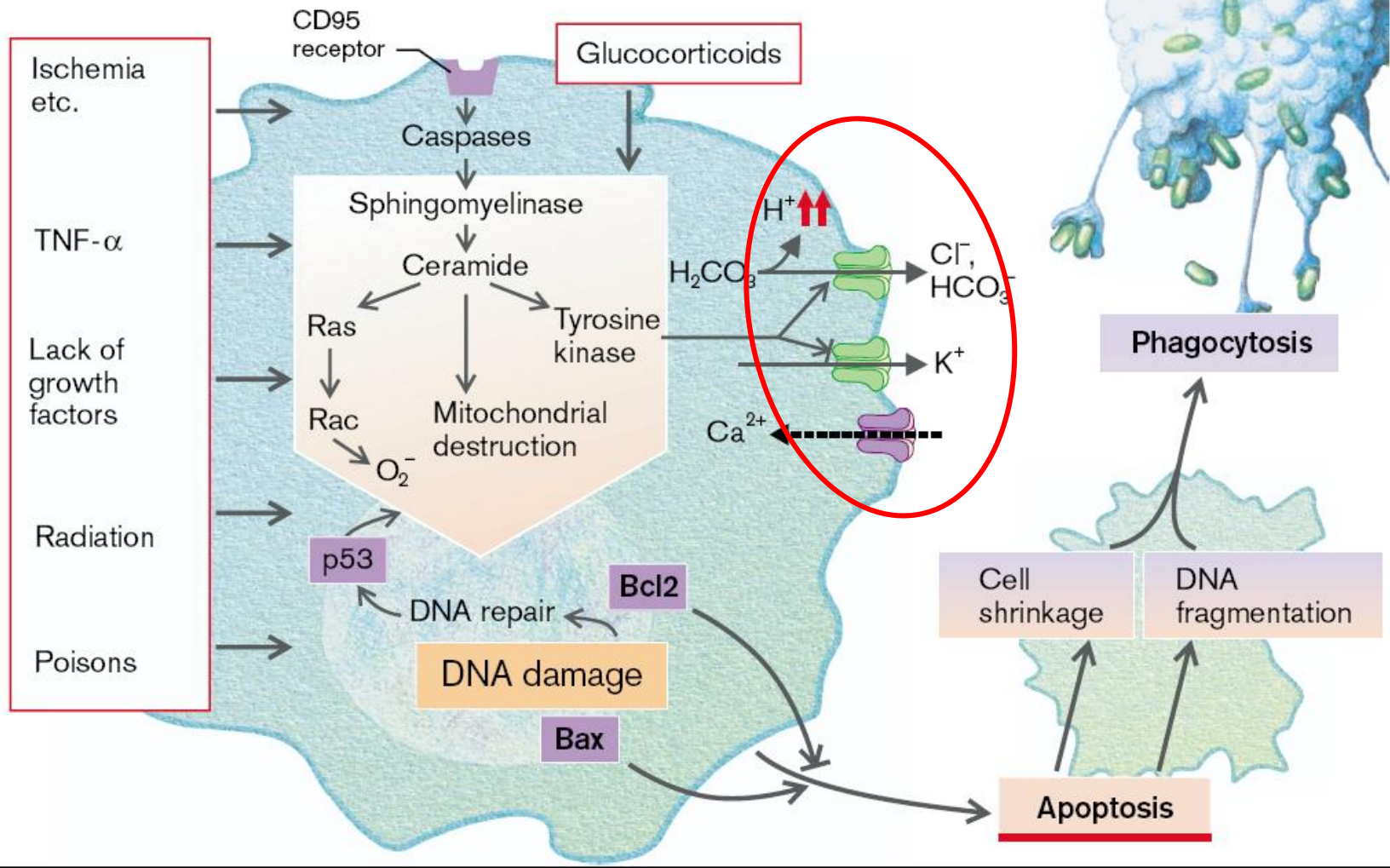

Už jste se potkali s kanály?

Buněčná migrace

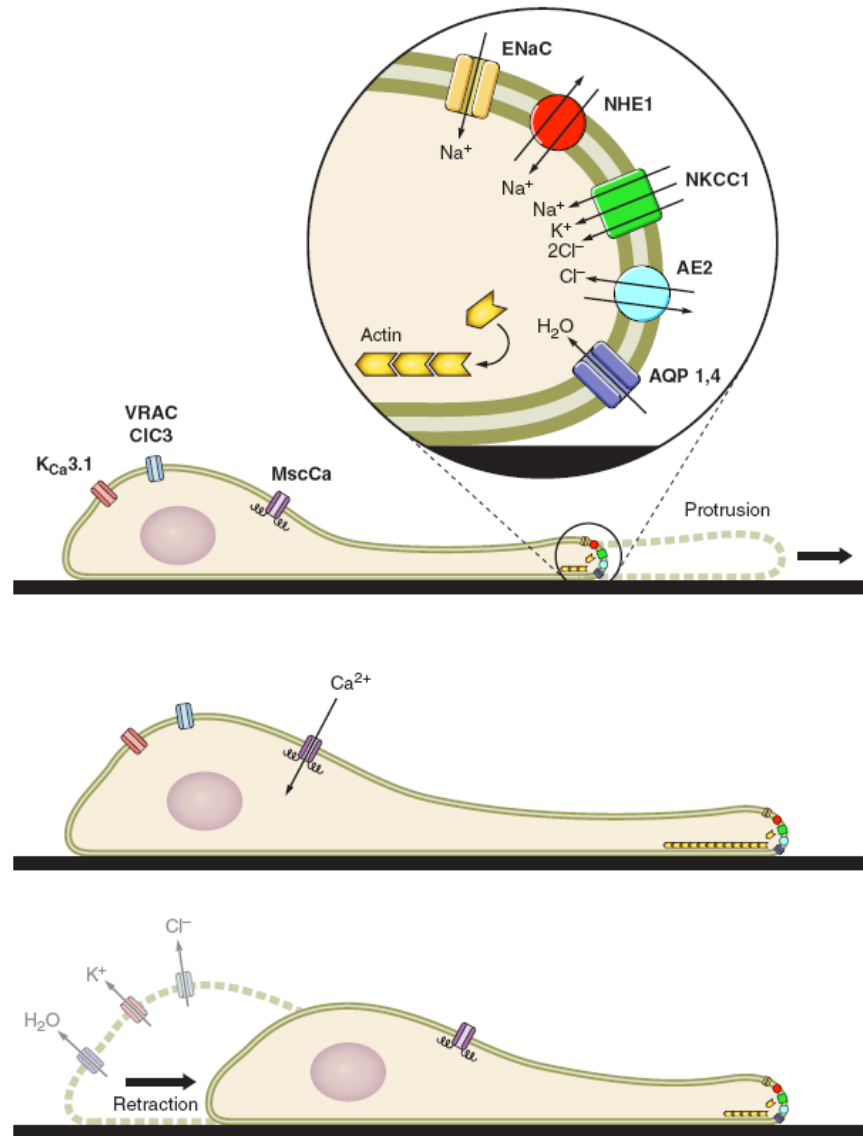

FIGURE 2. Cell volume changes during cell migration. Cell migration is a continuous cycle of protrusion of the cell front and retraction of the trailing end. This can be modeled as a cycle of isosmotic volume increase at the cell front and isosmotic volume decrease at the rear end. This model is based on direct measurements of volume changes in migrating cells [211, 515, 620] and on the subcellular distribution of the relevant ion transport proteins and aquaporins. The molecular nature of the mechanosensitive Ca²⁺ channels implicated in this model is still elusive. The scheme illustrates how members of the "transportome" cooperate during cell migration.

Kanály tedy řídí pasivní transport látek i předávají signály:

Spolupracují na udržení osmolality a membránového potenciálu - nezbytný pro aktivní transport.

Transporty konkrétně např.: sekrece pankreatické šťávy, žaludeční šťávy, sekrece a resorpce ve vylučování, resorpce ve střevě, osmotická a pH rovnováha,

Podílí se na signalizaci i mimo NS: celá Ca signalizace, svalový stah, buněčné signály

Podílí se na řízení proliferace, migrace buněk, buněčné morfologie, karcinogeneze, angiogeneze

Poruchy kanálů – např. srdce, cystická fibróza, vznik malformovaných metastazujících buněk.

Možná otázka

Jak se kanály zkoumají?

Terčíkový zámek (Patch clamp) – vidíme, jak kanál pracuje

1

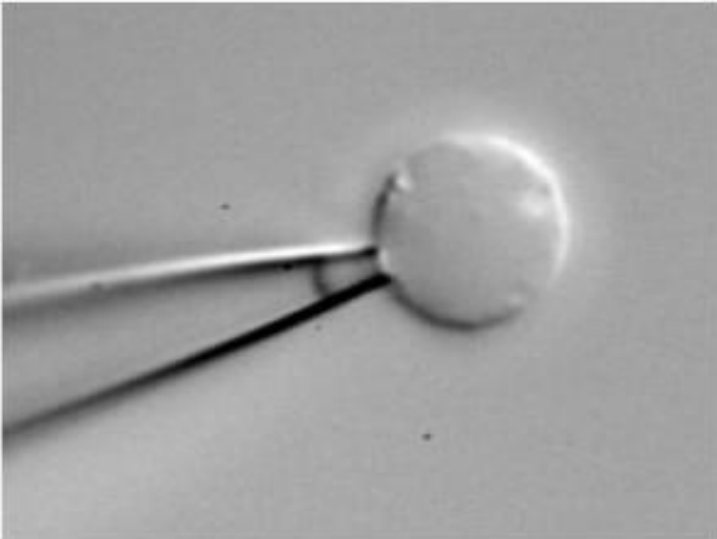

3

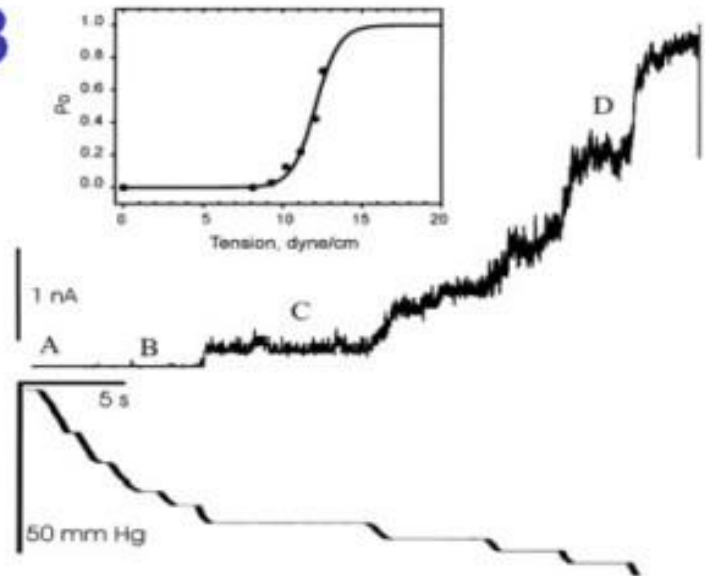

2

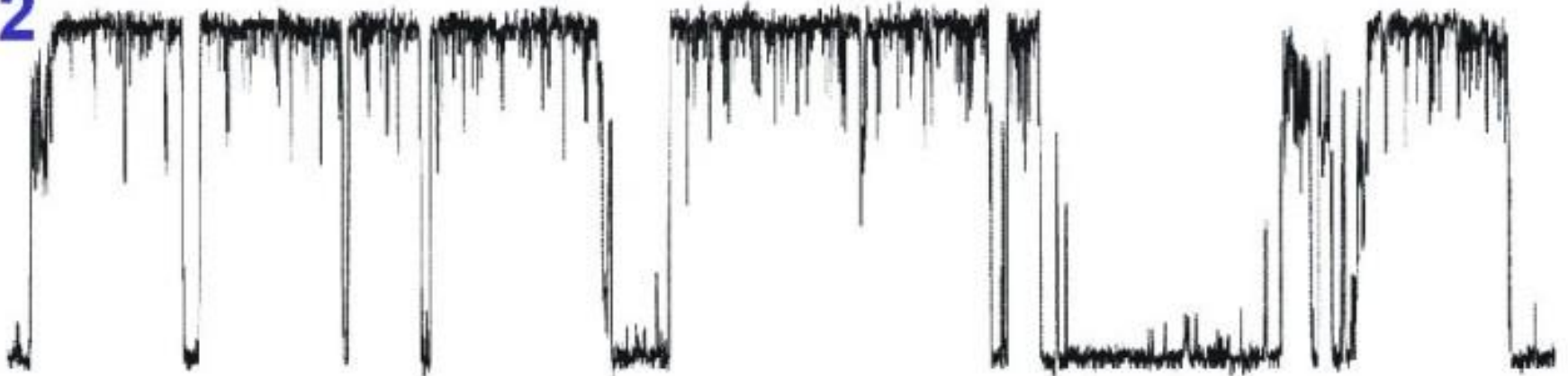

Jak se kanály zkoumají?

analýza sekvence AK –
Prostorová rekonstrukce ze složení
řetězce.

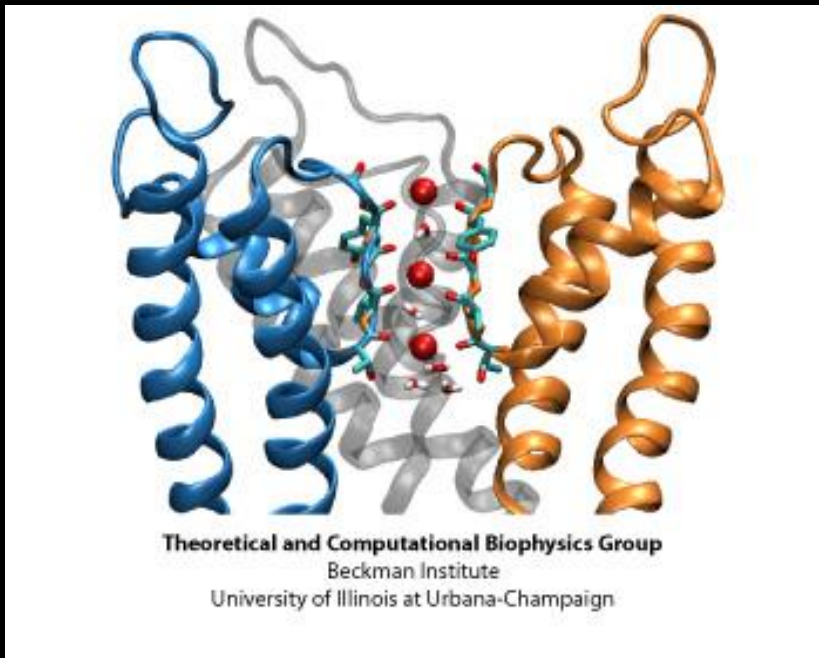
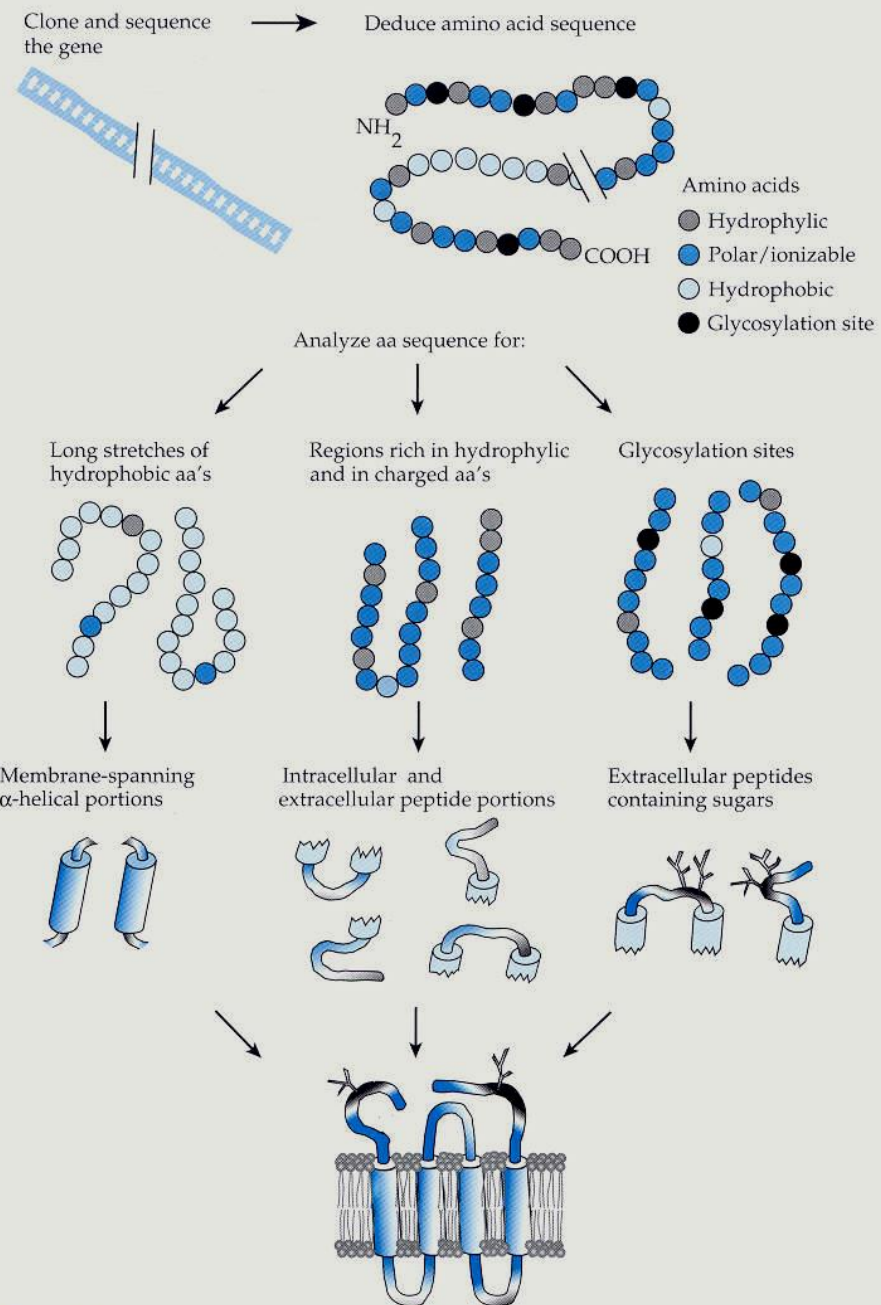
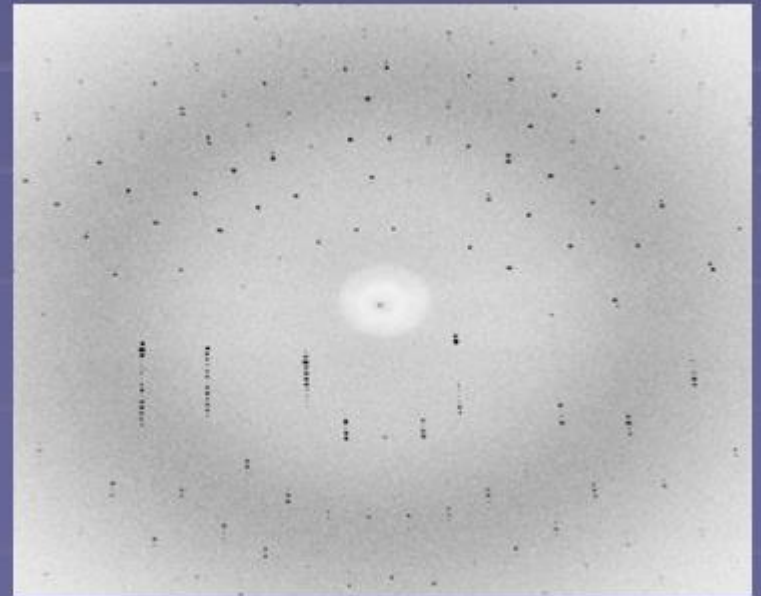
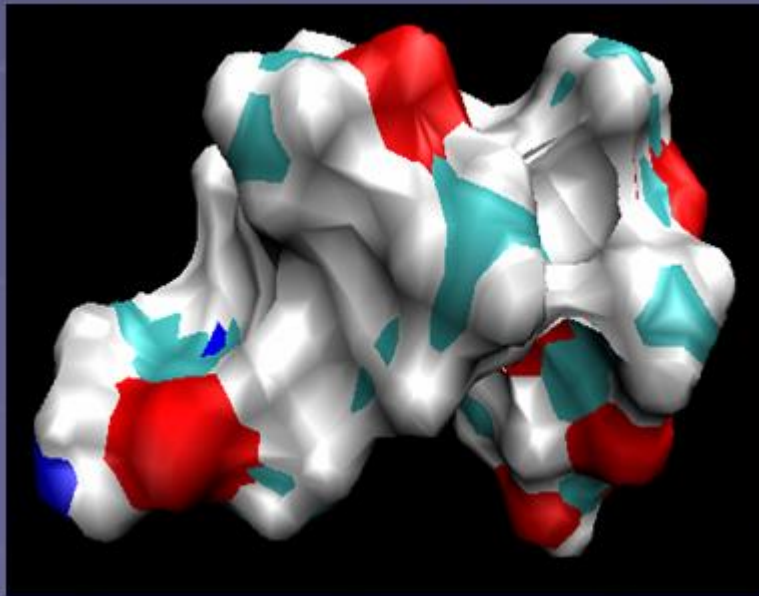
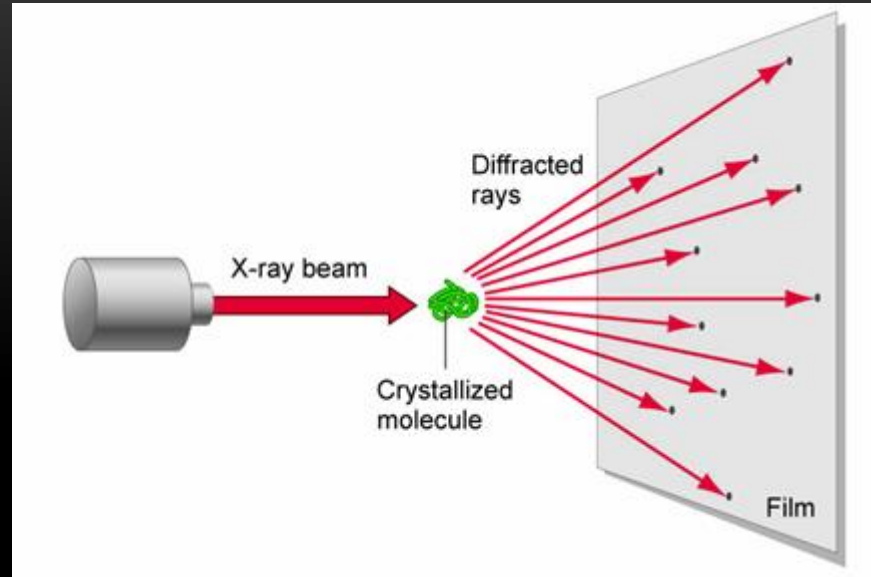

Figure 1.10
Analysis of hydrophathy and the folding of membrane proteins The amino acid sequence of a membrane protein can be used to make inferences about protein structure, as described in the text.

X ray krystalografie - vzhled



Jak se kanály zkoumají?

Možná otázka

FOTORECEPCE - ZRAK



Rhodopsin

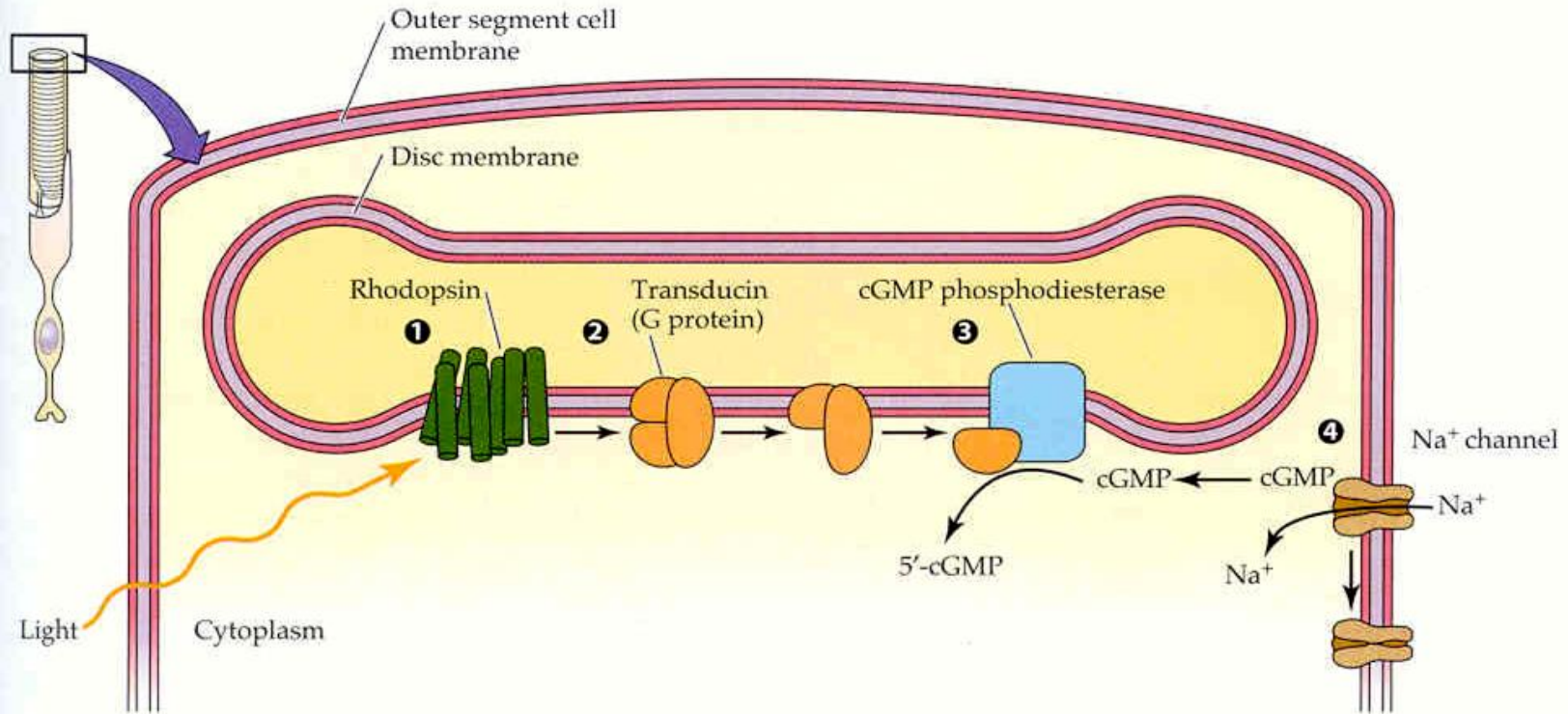
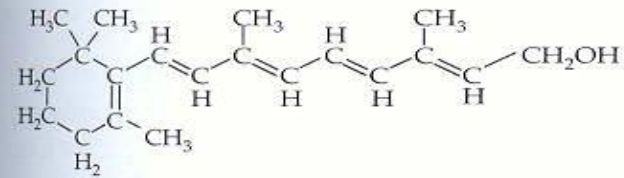

Figure 13.14 Phototransduction closes cation channels in the outer segment of the photoreceptor membrane In the dark, the cation channels are kept open by intracellular cGMP and conduct an inward current, carried largely by Na^+ . When light strikes the photoreceptor, these channels are closed by a G protein-coupled mechanism. **1** Rhodopsin molecules in the disc membrane absorb light and are acti-

vated. **2** The activated rhodopsin stimulates a G protein (transducin in rods), which in turn activates cGMP phosphodiesterase. **3** The phosphodiesterase catalyzes the breakdown of cGMP to 5'-GMP. **4** As the cGMP concentration decreases, cGMP detaches from the cation channels, which close.

Od 70. let obecné schéma G-proteinové signalizace
Nejprozkoumanější kaskáda

(a) Retinal and vitamin A



Complete structure of vitamin A (all-trans)

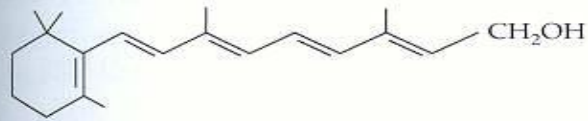

Condensed structure of vitamin A (all-trans)

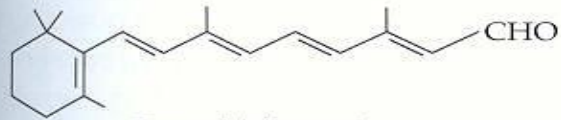

Retinal (all-trans)

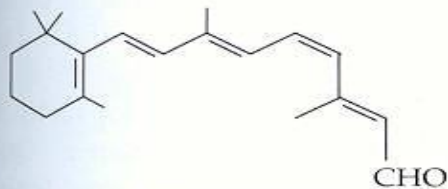

Retinal (11-cis)

(b) Opsin

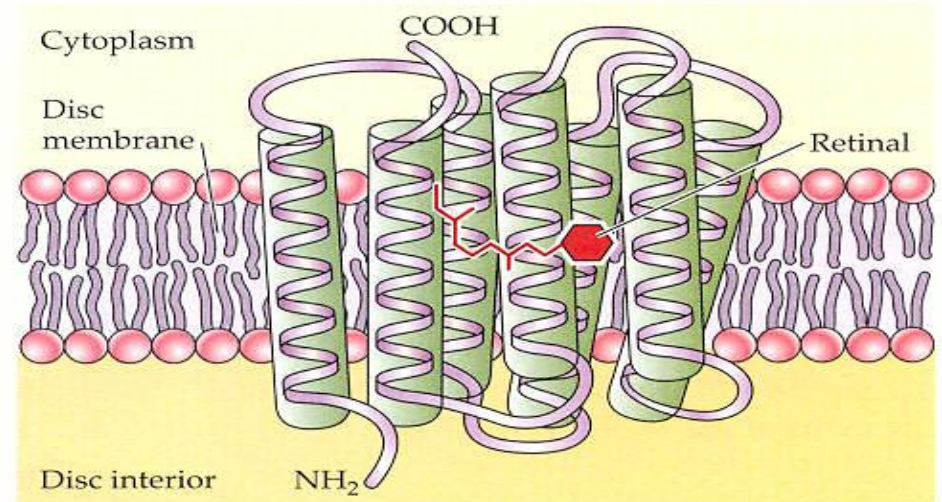
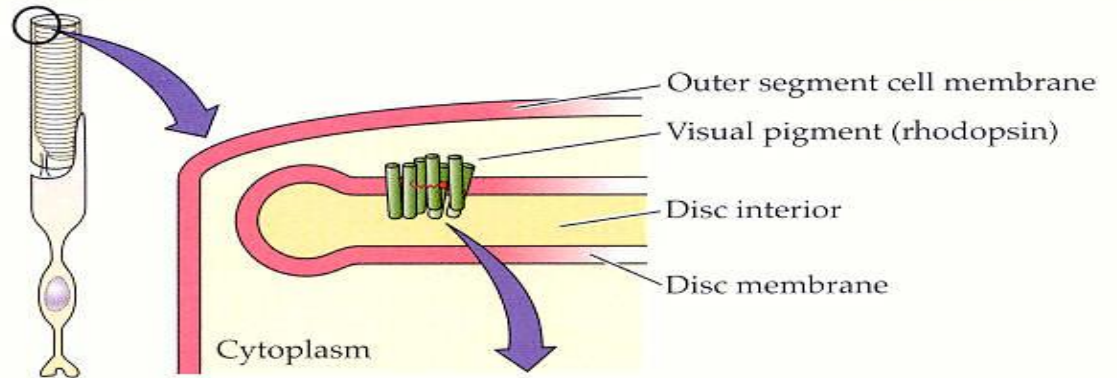

Prostetická skupina – chromofor nezbytná pro absorpci vyšších délek
 Chromofor ve funkci ligandu, světlo iniciuje

Drosophila jako užitečný model zrakové (a i jiné) transdukce:

Mimořádné zesílení – reakce na jediný foton

Nízký šum ve tmě (spontánní termální izomerizace)

Široká adaptace – rozsah až 10^6 (arrestin, Ca)

Rychlá terminace odpovědi

Nejrychlejší známá G signální dráha – 10x než obratlovci (10Hz u člověka)

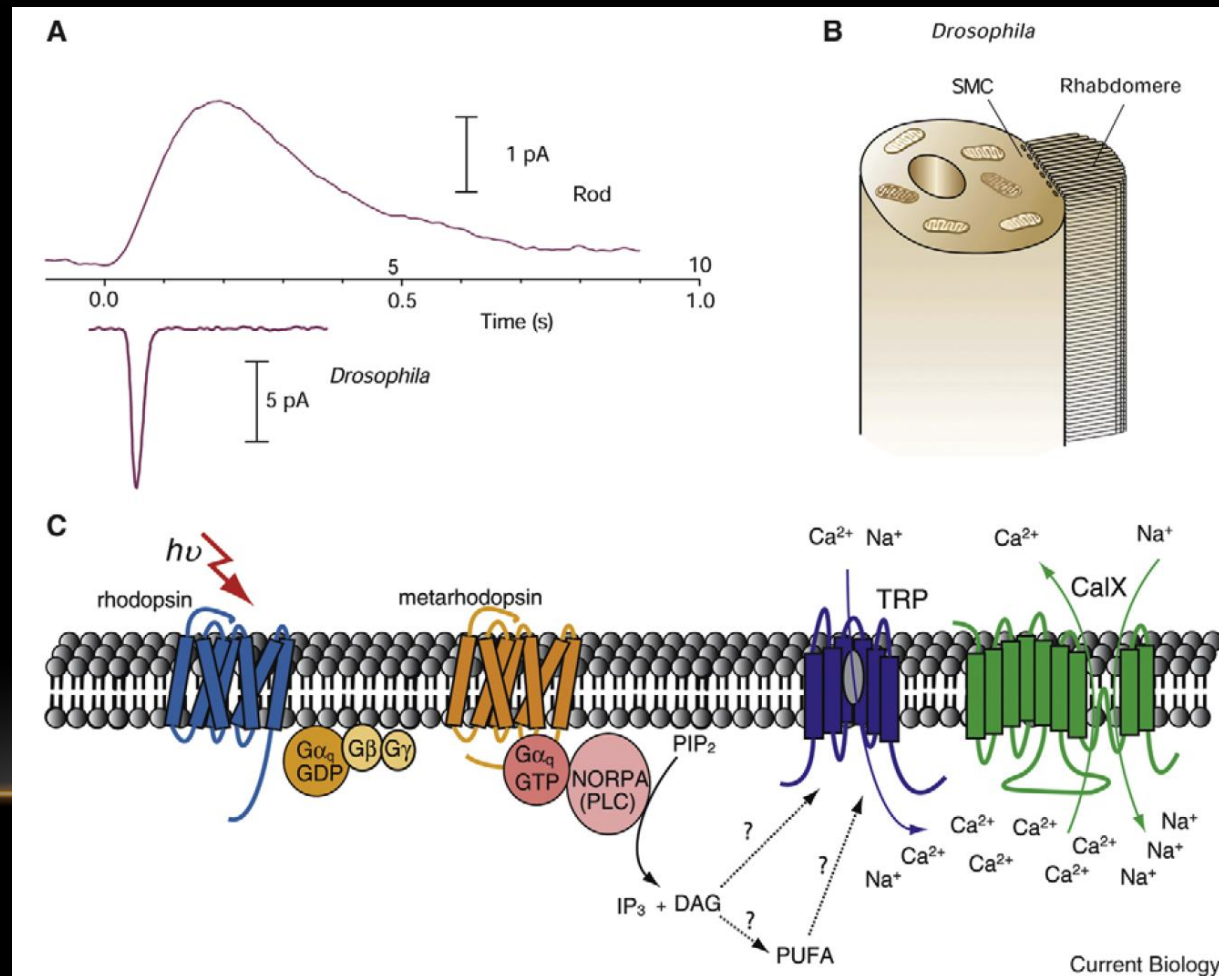

Drosophila jako užitečný model zrakové transdukce:

Taková rychlost? PLC octomilky je jeden z nejvýkonnějších známých enzymů-
limitem je jen přísun cGMP

Výkonnost transdukce omezena pouze difuzním pohybem v membráně.

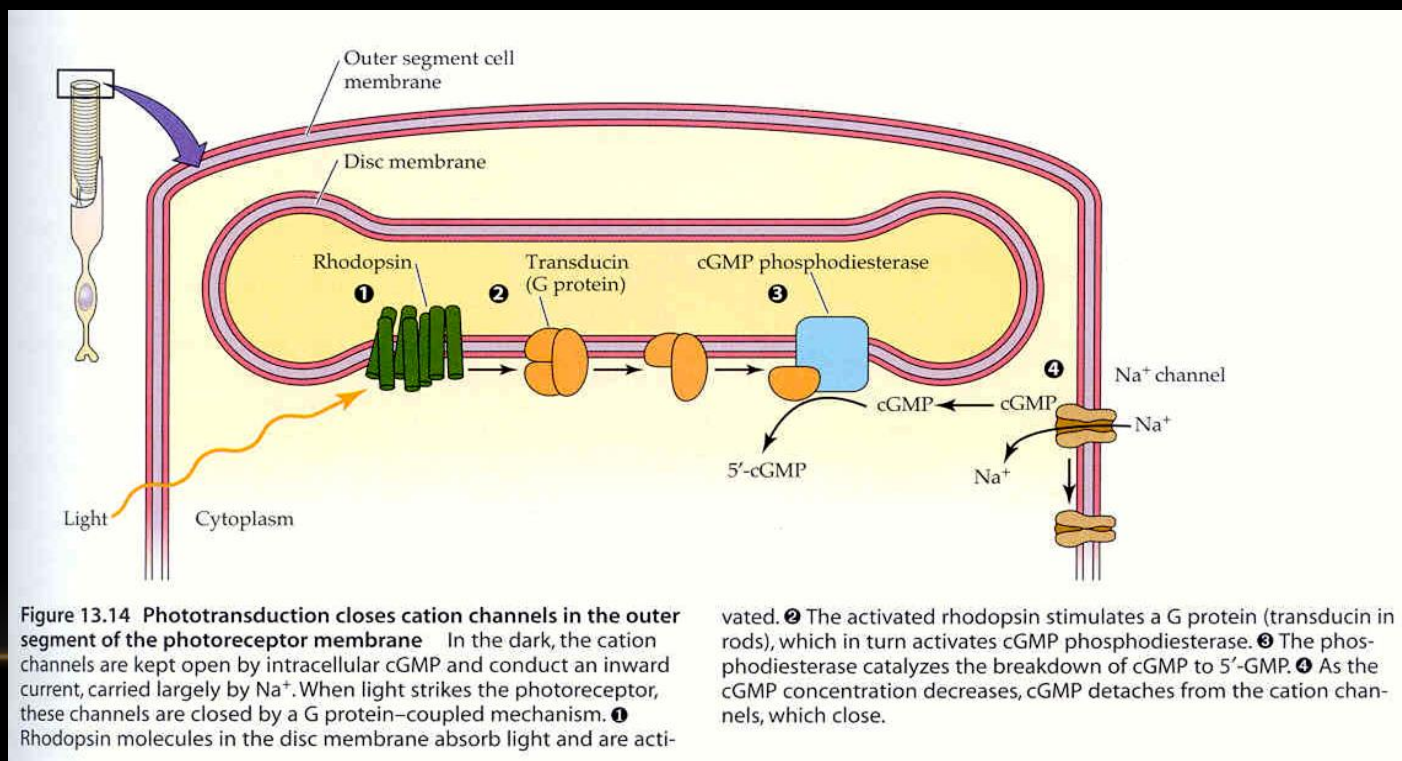

Drosophila jako užitečný model zrakové transdukce:

Difuzní model signálového přenosu x Signalplex, scaffolding proteins

Multimolekulární signalizační komplex zvyšuje rychlost a specifitu „rozhovorů“

TRP kanál (transient receptor potential) popsán u D.m. – viz dále

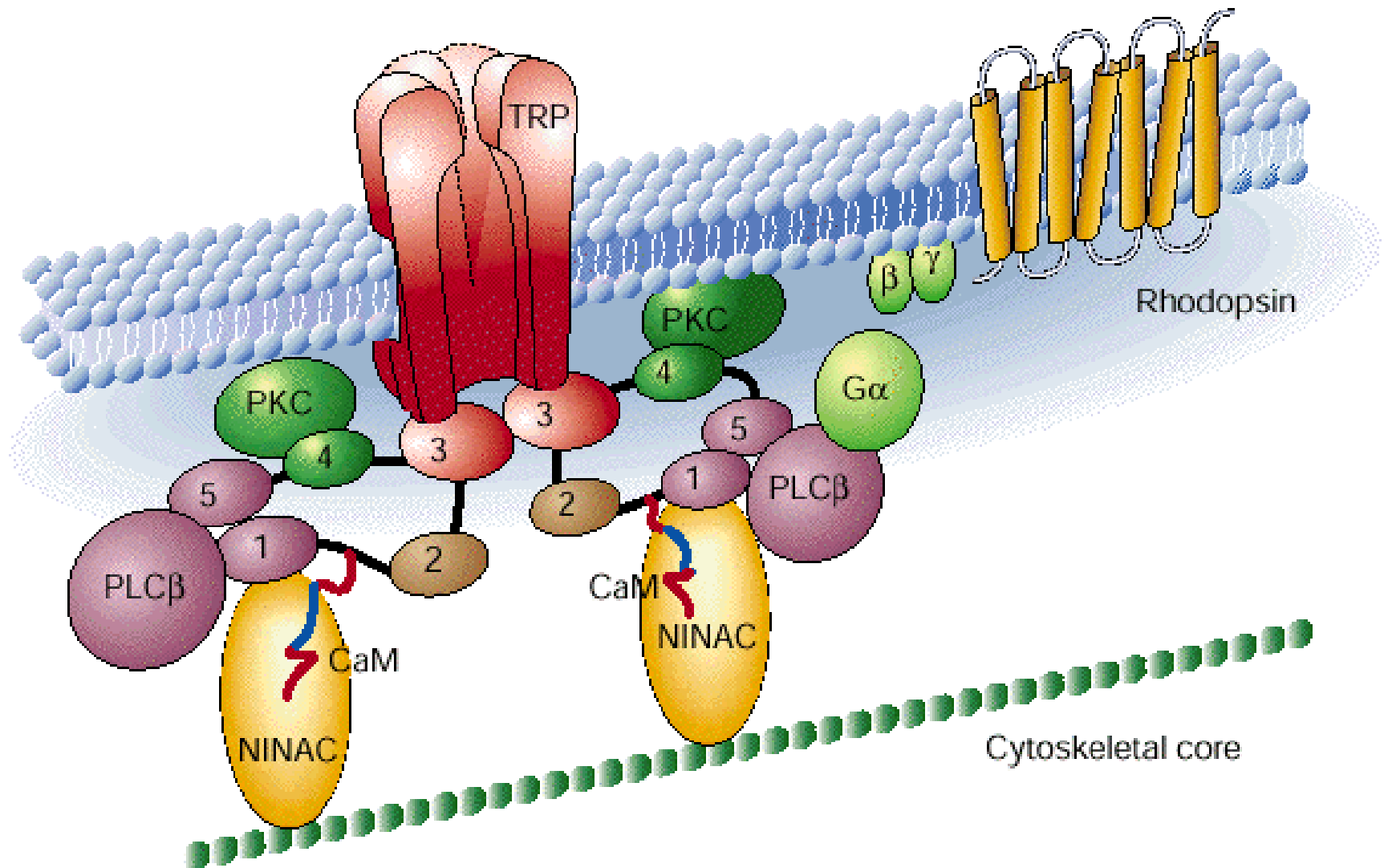

Drosophila jako užitečný model zrakové transdukce:

Organizace proteinů signalplexu
v čase a prostoru – oddělení, zhašení
v odpověď na světlo

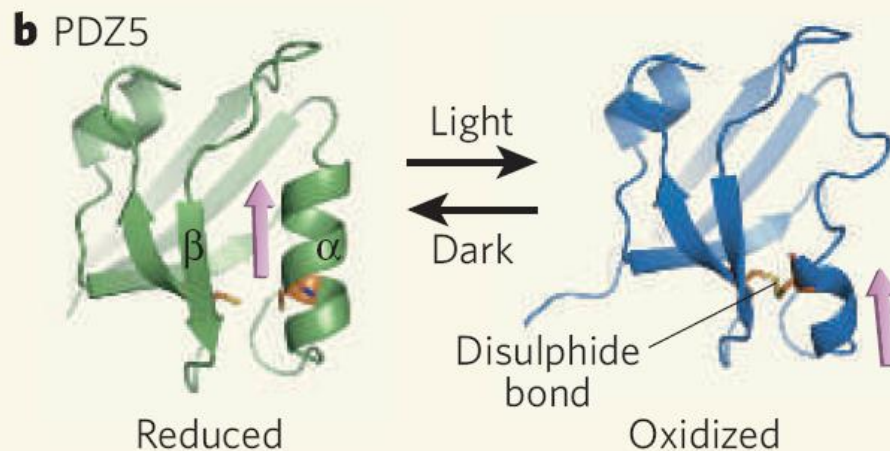
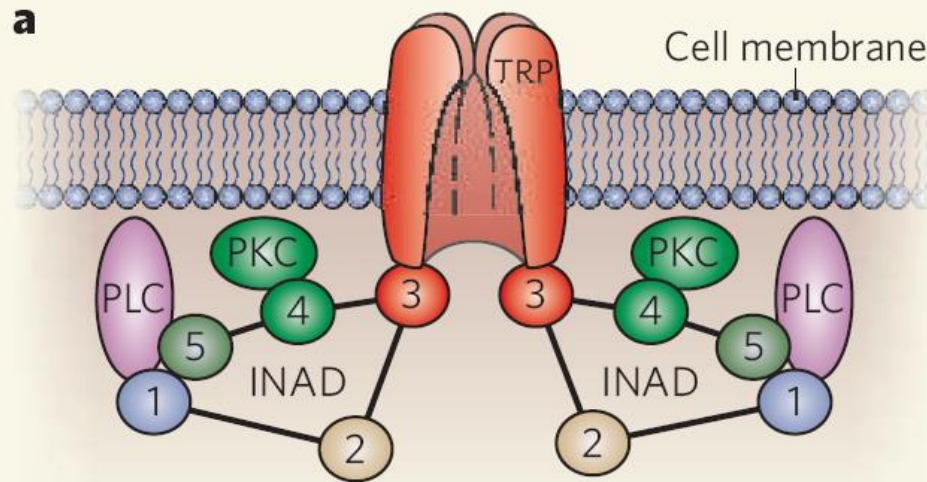
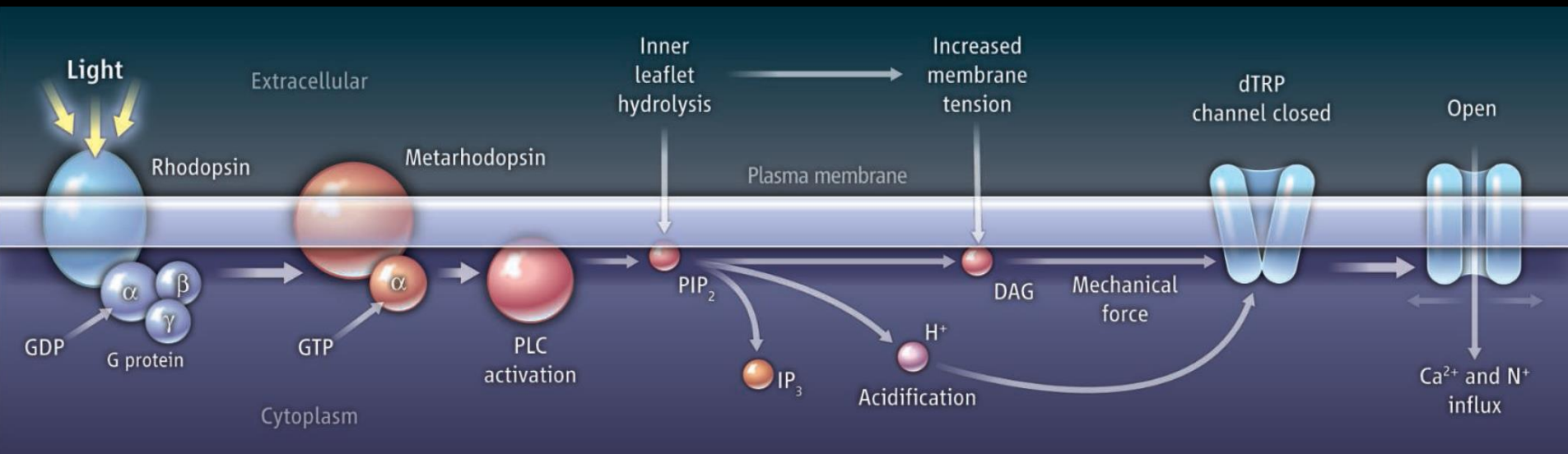
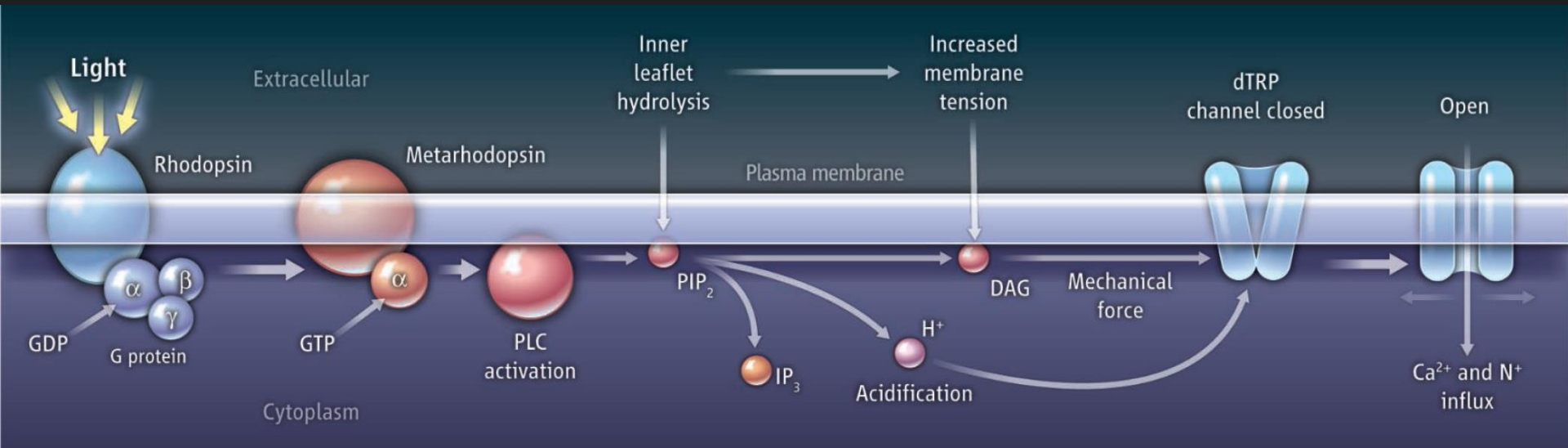

Figure 1 | Phototransduction in *Drosophila* and the INAD complex. **a**, The five PDZ domains of INAD (1–5) assemble components of the phototransduction cascade, including PLC, the TRP channel and PKC, into a signalling complex at the cell membrane. **b**, Mishra *et al.*² report that, in response to light, the PDZ5 domain of INAD undergoes a conformational change. In the dark, PDZ5 is in its canonical, reduced form, in which a groove between an α -helix and a β -sheet serves as a ligand-binding site. After stimulation with light, the PDZ5 domain undergoes a conformational change to an oxidized state, whereby the formation of a disulphide bond between two cysteine residues results in the unravelling of the α -helix and the distortion of the ligand-binding groove. Following this conformational switch, the ligand (arrowed) — putatively part of the PLC enzyme — can no longer bind. (Adapted from ref. 2.)

Drosophila jako užitečný model zrakové transdukce:

How does a light stimulus lead to the opening of TRP channels?
Surprising link between light-activated changes in membrane tension and the opening of TRP channels





The conclusion follows from a striking observation that light causes a contraction in the fly photoreceptors. Hardie and Franze quantitate this movement with atomic force microscopy and show that it reaches a peak of ~400 nm, with an onset that precedes the onset of the phototransduction current.

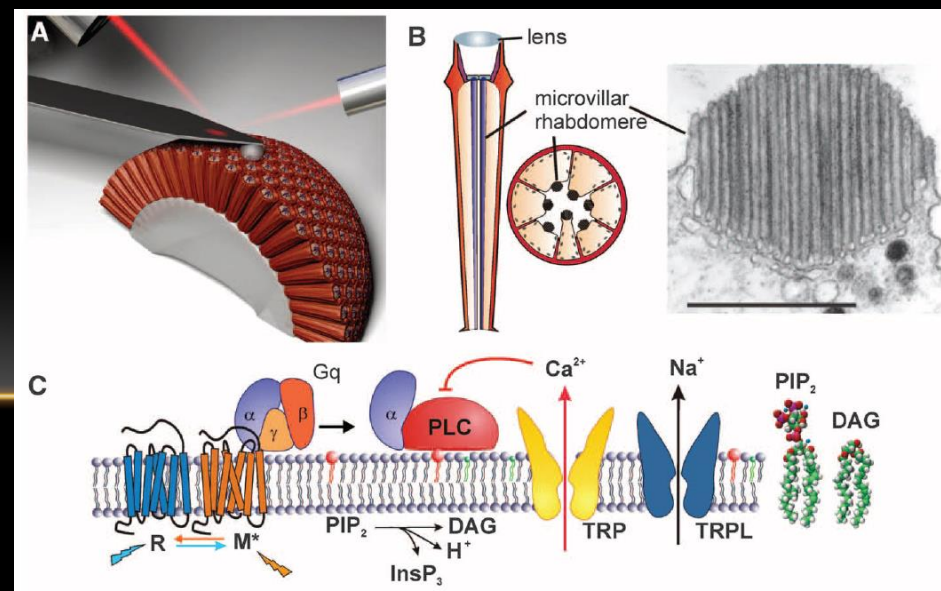

Drosophila jako užitečný model
 zrakové transdukce:
 Taková adaptace?
 Translokace TRP signalplexu –
 mechanismus adaptace
 na tmu a světlo

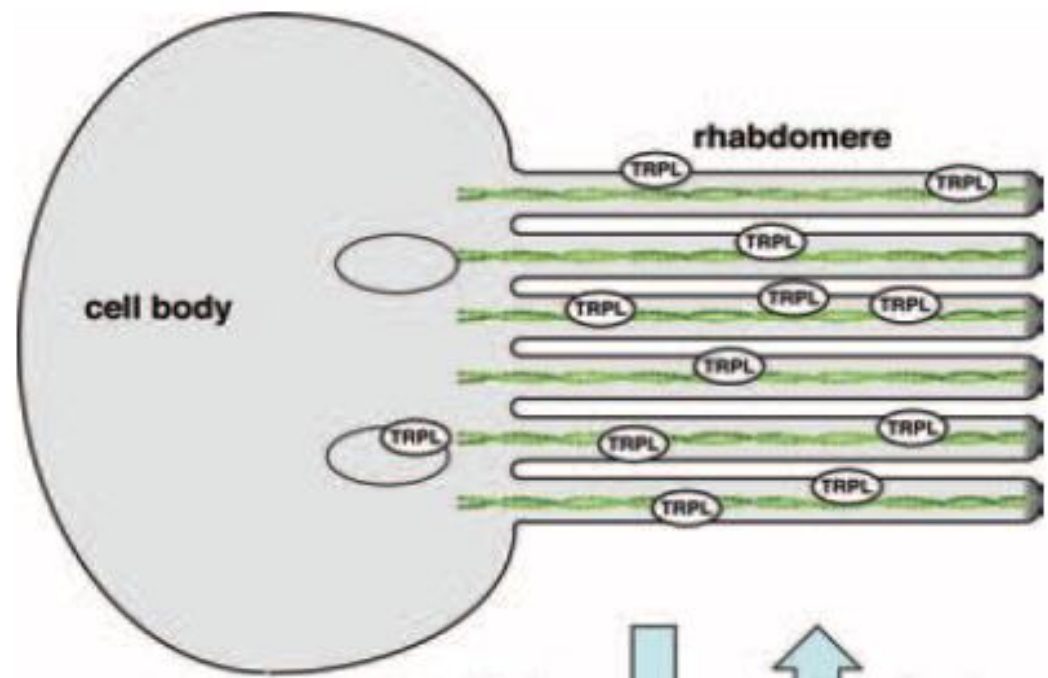

light ↓ ↑ dark

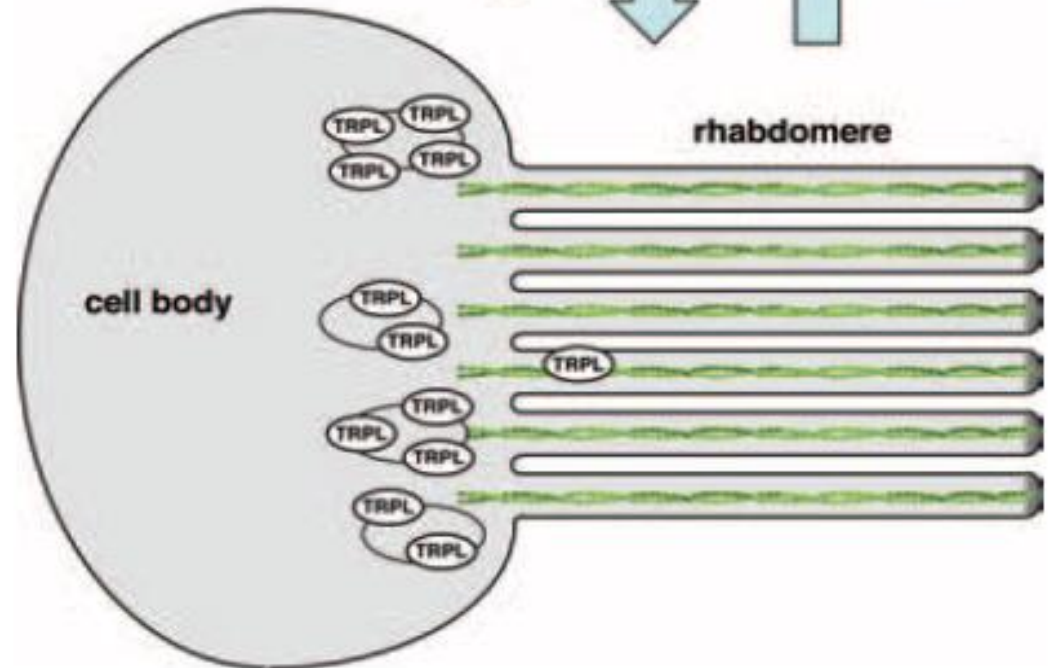

(a) Ommatidia

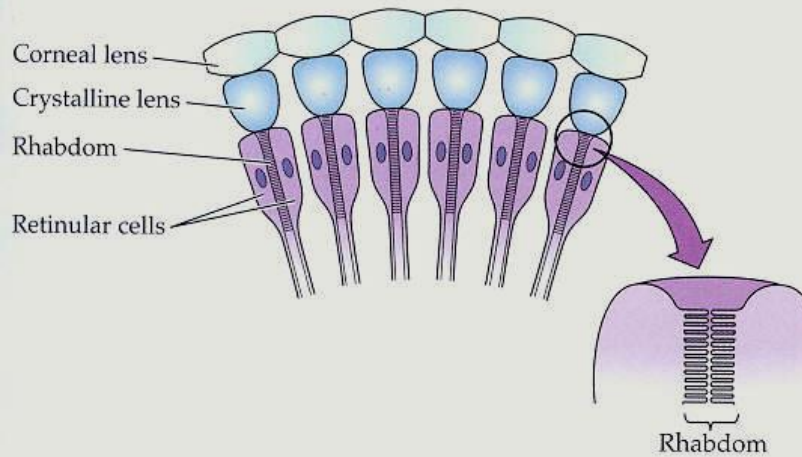

Čím přispěl výzkum fotorecepce Drosophily do poznání buněčné signalizace?
Co je to signálový komplex (transducizóm nebo také signalplex) a jaký má význam?

Možná otázka

Chemorecepce - čich



Všechny buňky umí čichat !
 Nejstarší smysl
 Konzervativní organizace
 Podobnost s rhodopsinem
 Jeden neuron – jeden receptor

Rozeznává tisíce látek
 1000 genů – 3% genomu!

Figure 2 Odorant receptors are the jewel of olfactory research in the past 10 years. The odorant receptors comprise the largest family of GPCRs. In mammals, odour receptors are represented by as many as 1,000 genes and may account for as much as 2% of the genome. Sequence comparison across the receptors has revealed many regions of conservation and variability that may be related to function. **a**, In a 'snake' diagram showing the amino acids for a particular receptor (M71), those residues that are most highly conserved are shown in shades of blue and those that are most variable are shown in shades of red. The seven α -helical regions (boxed) are connected by intracellular and extracellular loops. **b**, A schematic view of the proposed three-dimensional structure of the receptor based on the recently solved structure of rhodopsin. Each of the transmembrane regions is numbered according to that model. The conserved (blue) and variable (red) regions are sketched onto this qualitative view and suggest that a ligand-binding region may be at least partially formed by the variable regions of the receptor. **c**, Mammalian odour receptors are related phylogenetically to other chemosensory receptors. In the tree depicted here the numbers refer to the approximate number of receptors in each family. OR, Odorant receptors; T1R, T2R, taste receptors; V3R, vomeronasal receptors; DOR, DGR, *Drosophila* odour and gustatory receptors; worm refers to *C. elegans*. The scale bar is a graphical distance equal to 10% sequence divergence.

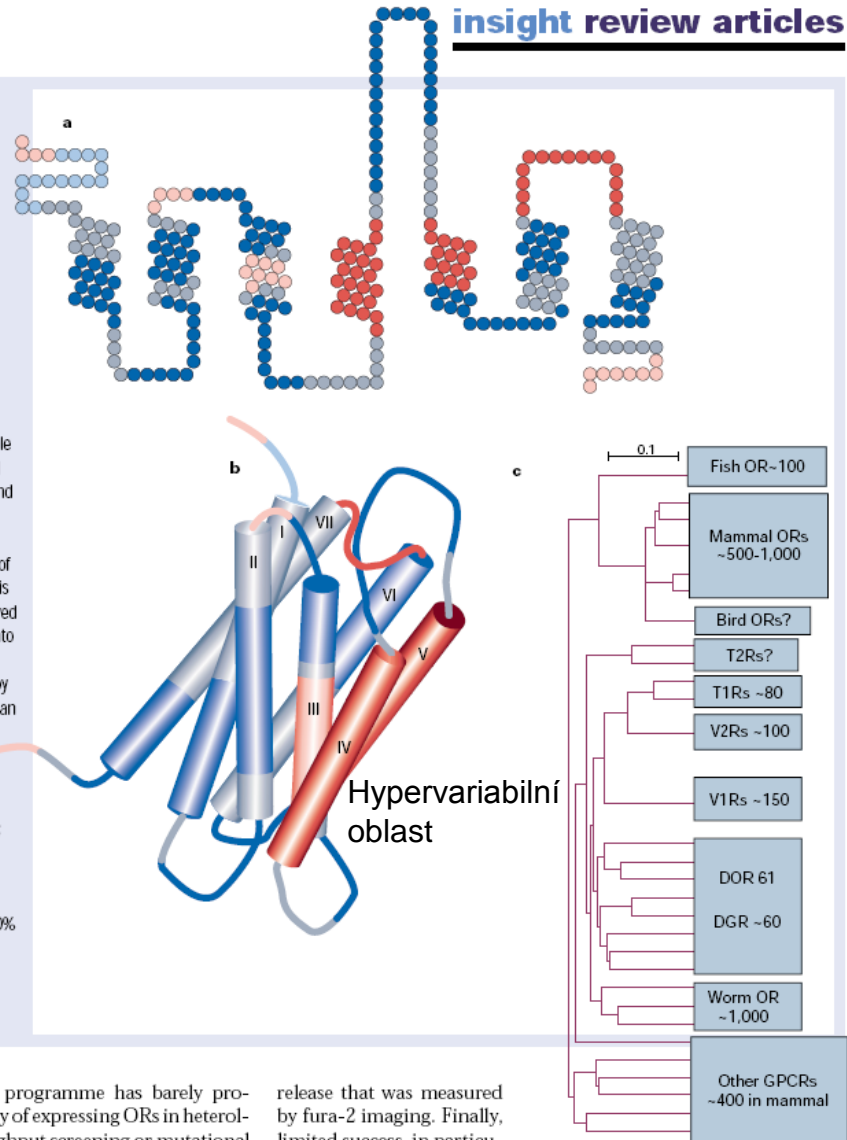

But this ambitious experimental programme has barely progressed, owing to the puzzling difficulty of expressing ORs in heterologous systems suitable for high-throughput screening or mutational

release that was measured by fura-2 imaging. Finally, limited success, in particu-

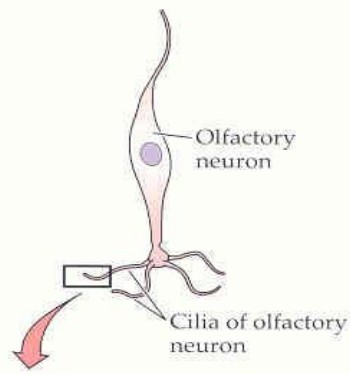
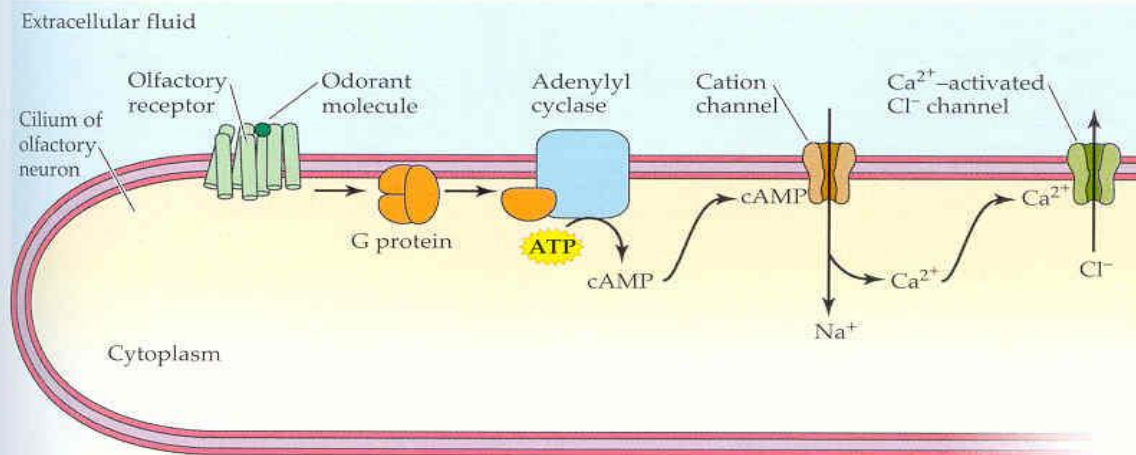
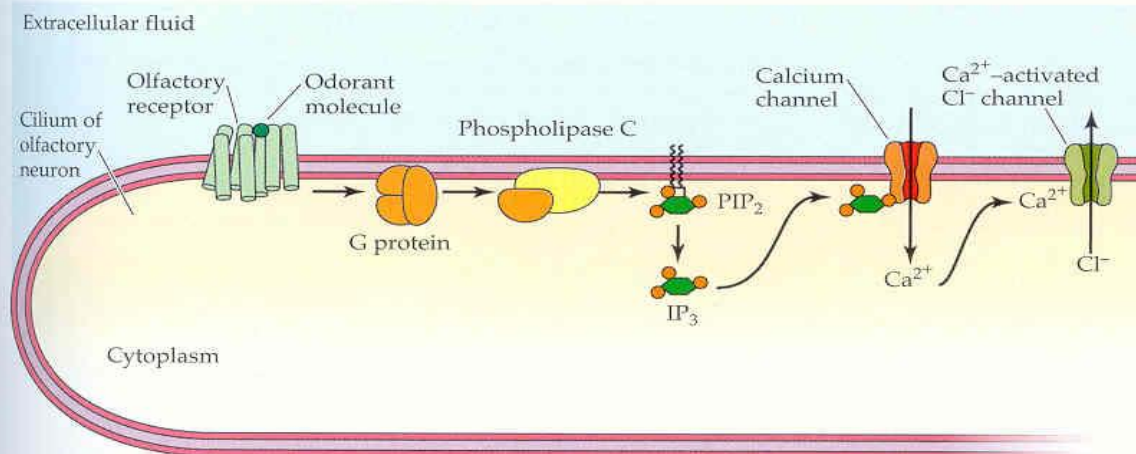

Figure 13.36 Olfactory transduction mechanisms in cilia membranes of olfactory neurons (a) Many odorants act to increase cyclic AMP. The odorant binds to an odorant receptor on the ciliary membrane; the receptor activates a G protein to activate adenylyl cyclase, producing cAMP. Cyclic AMP binds to and opens a cation channel, allowing entry of Na^+ and Ca^{2+} ions to depolarize the cell. Ca^{2+} binds to Ca^{2+} -activated Cl^- channels, augmenting the depolarization. (b) Some olfactory responses increase IP_3 . This mechanism also starts with odorant binding to a G protein-coupled receptor, but in this case the G protein activates phospholipase C, forming IP_3 from PIP_2 (see Figure 12.21). IP_3 binds to and opens a calcium channel, letting Ca^{2+} enter to depolarize the cell. As in (a), Ca^{2+} -activated Cl^- channels augment the depolarization.

(a) Increase in cAMP



(b) Increase in IP_3



G-prot. signální dráha

G-prot. signální dráha

Figure 3 Sensory transduction. Within the compact cilia of the OSNs a cascade of enzymatic activity transduces the binding of an odorant molecule to a receptor into an electrical signal that can be transmitted to the brain. As described in detail in the text, this is a classic cyclic nucleotide transduction pathway in which all of the proteins involved have been identified, cloned, expressed and characterized. Additionally, many of them have been genetically deleted from strains of mice, making this one of the most investigated and best understood second-messenger pathways in the brain. AC, adenylyl cyclase; CNG channel, cyclic nucleotide-gated channel; PDE, phosphodiesterase; PKA, protein kinase A; ORK, olfactory receptor kinase; RGS, regulator of G proteins (but here acts on the AC); CaBP, calmodulin-binding protein. Green arrows indicate stimulatory pathways; red indicates inhibitory (feedback).

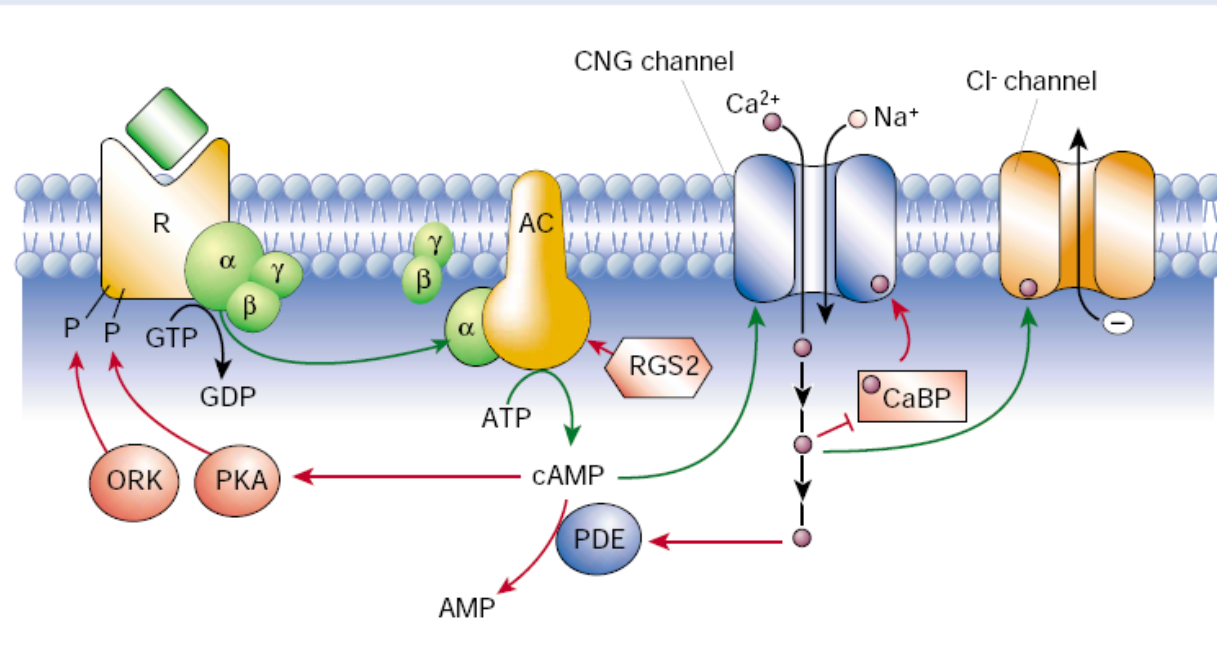

2004 Nobelova cena

50% léků přes G-proteinové signální dráhy

Jeden neuron – jeden receptor –
jedna základní vůně

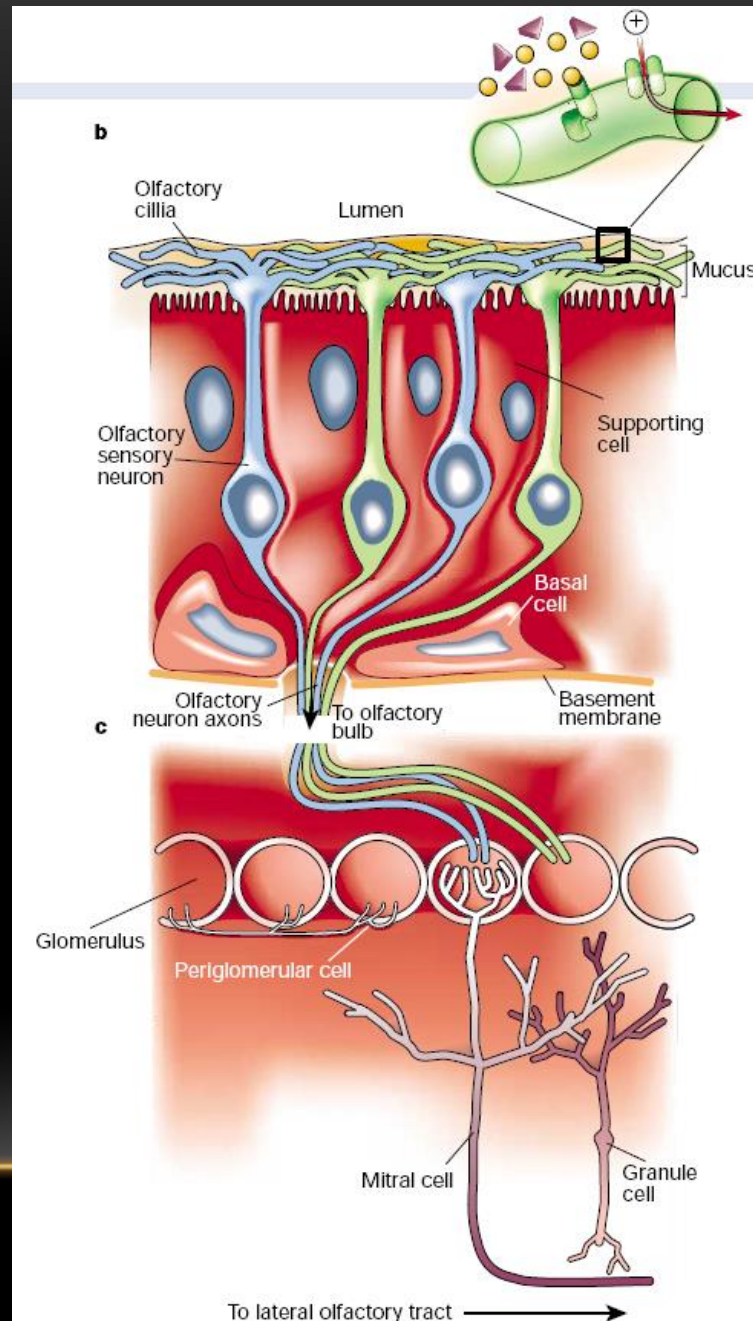

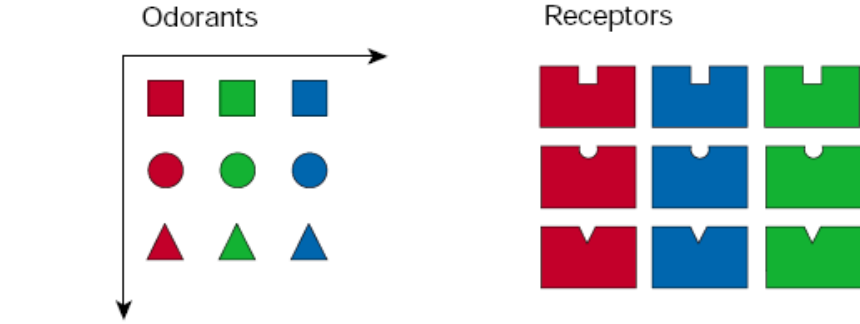

Pattern of peripheral activation

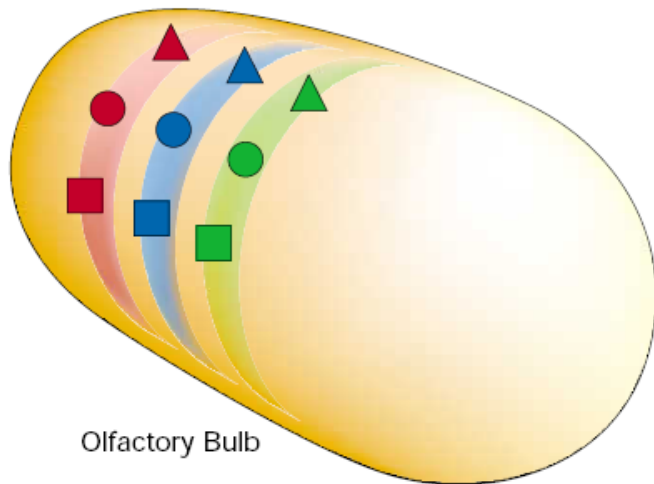
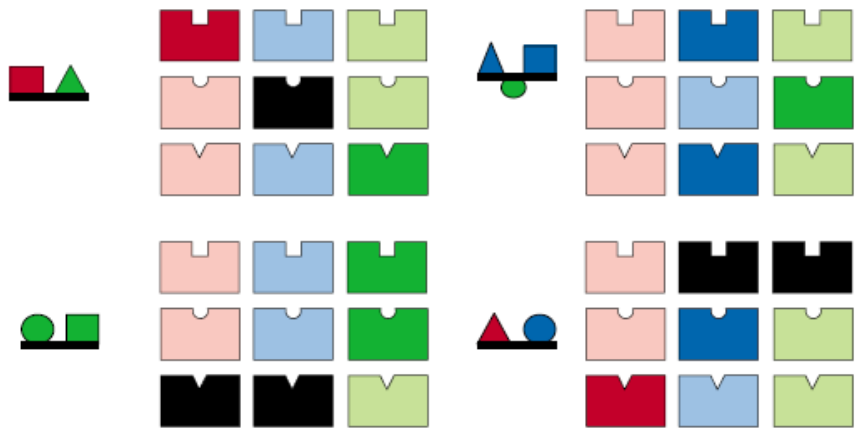

Olfactory Bulb

Although there are some 1,000 ORs, detecting the enormous repertoire of odours requires a combinatorial strategy. Most odour molecules are recognized by more than one receptor (perhaps by dozens) and most receptors recognize several odours, probably related by chemical property. The scheme in the figure represents a current consensus model. There are numerous molecular features, two of which are represented here by colour and shape. Receptors are able to recognize different features of molecules, and a particular odour compound may also consist of a number of these 'epitopes' or 'determinants' that possess some of these features. Thus the recognition of an odour molecule depends on which receptors are activated and to what extent, as shown by the shade of colour (black represents no colour or shape match and thus no activation). Four odour compounds are depicted with the specific array of receptors each would activate. Note that there are best receptors (for example, red square), but also other receptors that are able to recognize some feature of the molecule (for example, any square) and would participate in the discrimination of that compound. In the olfactory bulb there seem to be wide areas of sensitivity to different features (for example, functional group or molecular length). This model is based on current experimental evidence, but is likely to undergo considerable revision as more data become available.

Téměř neomezené množství kombinací-distanční imunitní sst. (?)

Specifická „mozaika“ aktivace pro konkrétní vůni

CHEMORECEPCE - CHUŤ



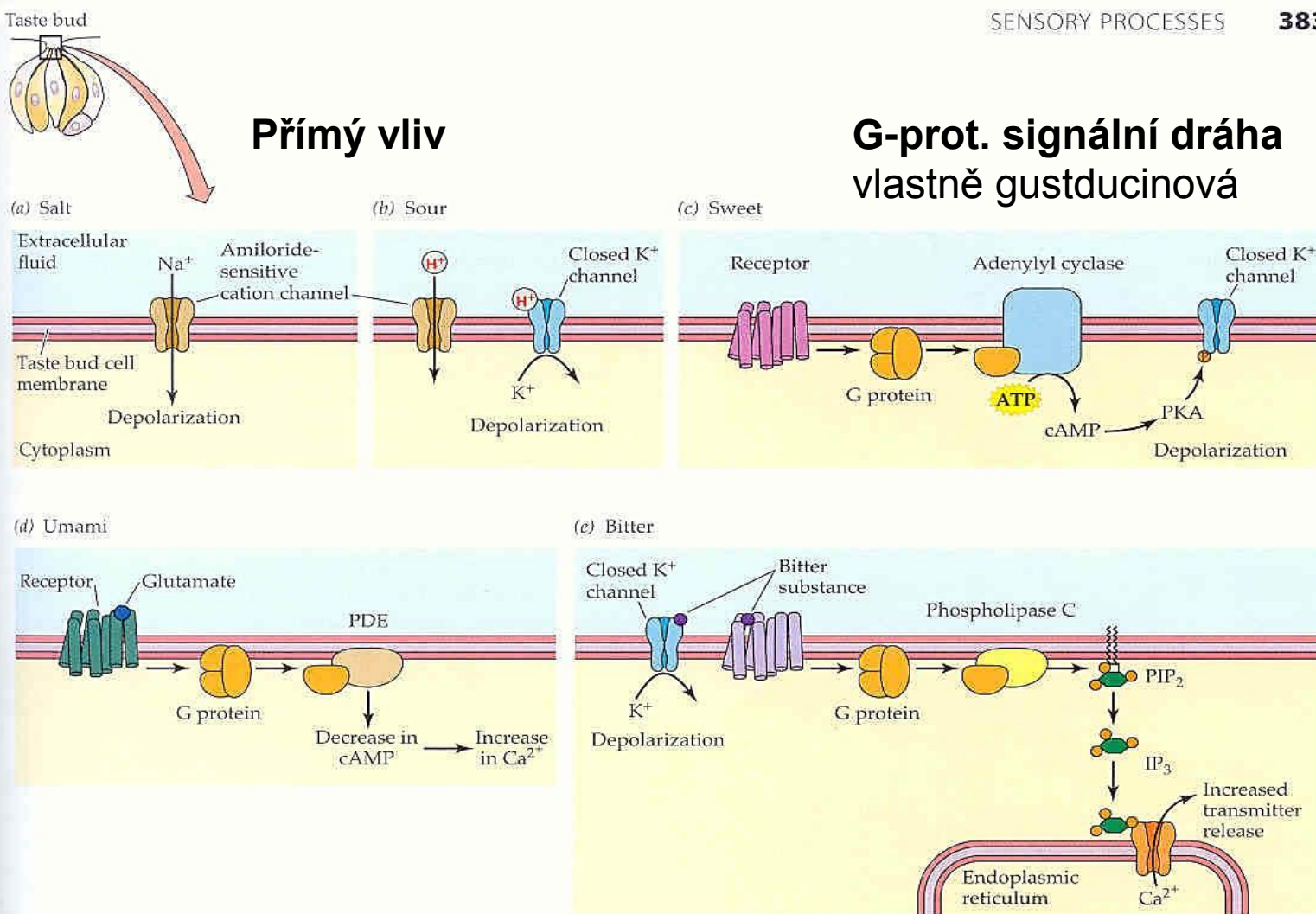
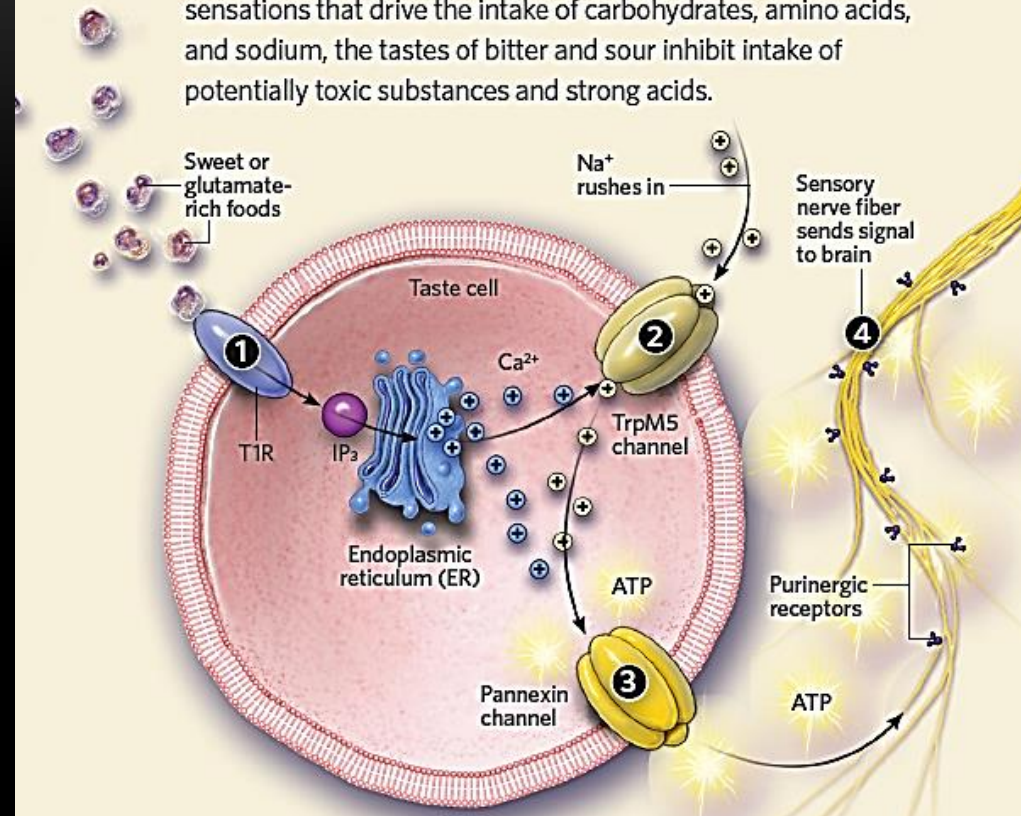

Figure 13.34 Taste-transduction mechanisms differ for different taste qualities All transduction mechanisms except the IP_3 action in (e) lead to *depolarization*, which spreads to the basal end of the cell and opens voltage-gated Ca^{2+} channels to allow Ca^{2+} entry and transmitter release. (a) For salt taste, sodium ions enter a taste bud cell through amiloride-sensitive cation channels, directly depolarizing the cell. (b) In sour taste, either H^+ ions enter the cell through amiloride-sensitive cation channels, or they close K^+ channels to produce depolarization. (c) Sweet taste is most commonly mediated by the binding of sugars to a G protein-coupled receptor, which acts via a G protein to activate adenylyl cyclase and produce cyclic AMP. Cyclic AMP then activates protein kinase A (PKA) to close a K^+ channel (by phosphorylating

it), producing depolarization. (d) The amino acid glutamate (monosodium glutamate, MSG) stimulates the taste quality umami (a savory or meaty quality). Glutamate binds to a G protein-coupled receptor (related to synaptic metabotropic glutamate receptors) to activate a phosphodiesterase (PDE) and decrease the concentration of cAMP. The decrease in cAMP leads to an increase in intracellular Ca^{2+} concentration. (e) Bitter taste mechanisms can involve a G protein-coupled receptor for bitter substances that acts via a G protein and phospholipase C to produce IP_3 . IP_3 liberates Ca^{2+} ions from intracellular stores, eliciting transmitter release without requiring depolarization. Other bitter substances bind to K^+ channels and close them to depolarize the cell.

TASTE IN THE MOUTH

Taste-bud receptors, primarily on the tongue, sense the qualities of salty, sour, bitter, sweet, and umami (the taste of glutamate). While sweet, umami, and salty foods provide pleasurable sensations that drive the intake of carbohydrates, amino acids, and sodium, the tastes of bitter and sour inhibit intake of potentially toxic substances and strong acids.



THE TASTE SIGNALING CASCADE IN THE MOUTH

The binding of molecular components of sweet or glutamate-rich foods to T1R-class receptors and bitter substances to T2R receptors stimulates the release of Ca²⁺ into the cytosol from the endoplasmic reticulum (ER) via G protein signaling and the second messenger molecule inositol trisphosphate (IP₃) **1**. The Ca²⁺ activates the TrpM5 channel to allow the entry of sodium ions (Na⁺), depolarizing the cell **2**. The combination of depolarization resulting from the influx of Na⁺ and rise in intracellular Ca²⁺ opens pannexin channels in the taste-cell membrane, releasing ATP from the cell **3**. This in turn activates purinergic receptors on the sensory nerve fibers innervating the taste buds, thereby sending a signal to the brain **4**.

ANDREW SWIFT
FOR THE SCIENTIST, NOVEMBER 2011

Všimněme si:
TRP Na kanál (viz dále)
ATP jako mediátor

TASTE IN THE GUT

In contrast to taste receptors in the mouth, T1R and T2R receptors in the gut do not induce sensations of taste, but rather initiate molecular pathways that help guide the digestion or rejection of food substances traveling through the intestines. The underlying pathways, however, have many similarities.

FOODS IN THE GUT

A Specialized endocrine cells of the small intestine, known as enteroendocrine cells, display T2R bitter receptors on their cell membranes. When bitter compounds bind to the T2R receptors, the cells release the peptide hormone cholecystikinin (CCK), which acts on CCK2 receptors located on enterocytes, or intestinal absorptive cells. This increases the expression of the transporter ABCB1, which pumps toxins or unwanted substances out of the cell and back into the intestinal lumen. CCK also binds to CCK1 receptors on sensory fibers of the vagus nerve, sending signals to the brain to cease food intake.

B T1R-class receptors on enteroendocrine cells lining the small intestine detect sweet substances and respond by secreting the glucagon-like peptide GLP-1. GLP-1 then travels to the pancreas via the bloodstream, where it boosts the release of insulin from pancreatic β -cells, promoting the uptake of glucose by diverse tissues. Additionally, GLP-1 diffuses to neighboring enterocyte cells in the small intestine, driving the insertion of the glucose transporters SGLT-1 and GLUT2, which facilitates the uptake of glucose from the intestines.

C In the colon, bitter ligands bind to T2R receptors on epithelial cells, where they induce the secretion of anions and water, which leads to fluid rushing into the intestine, resulting in diarrhea that flushes out the colon.

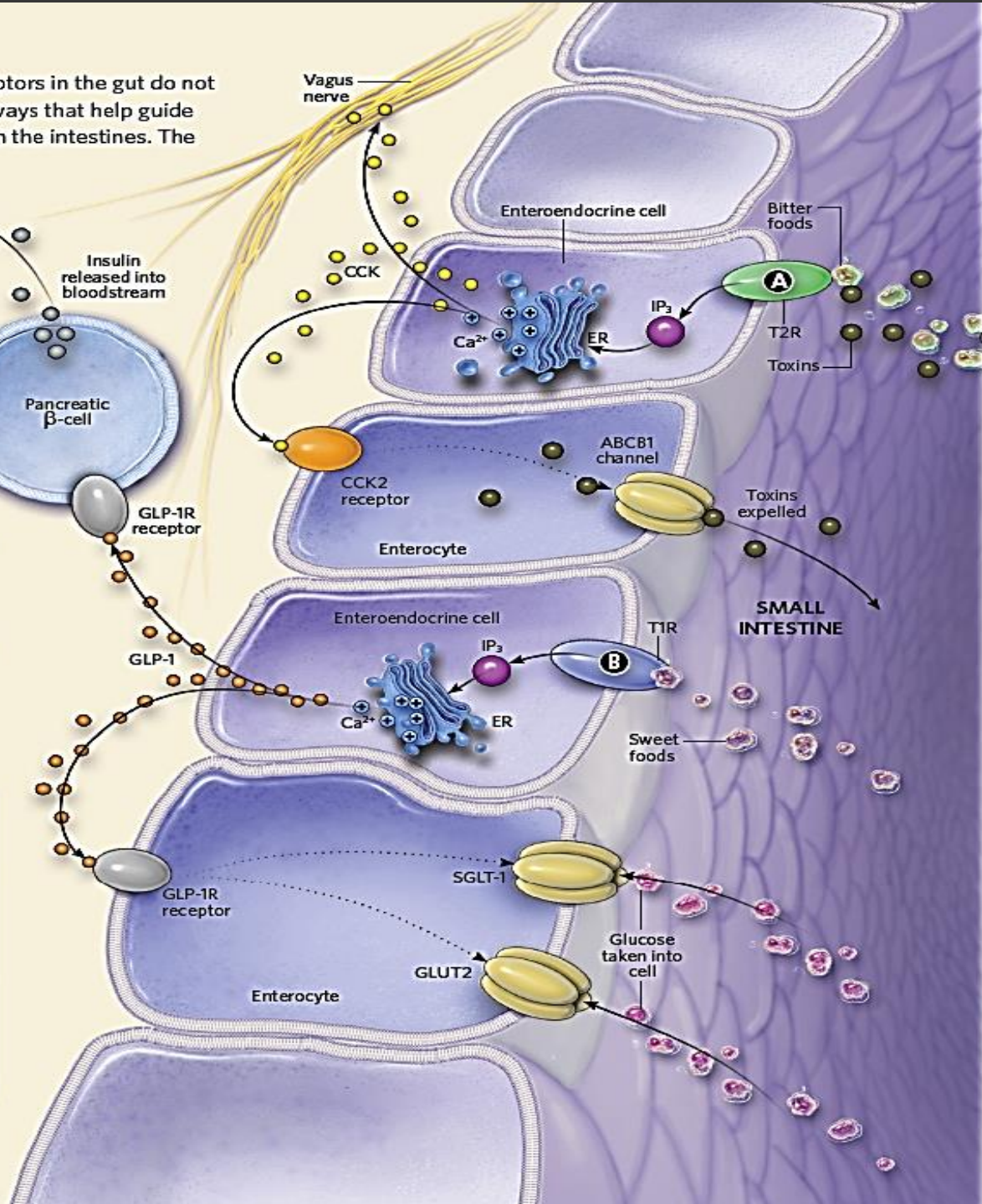
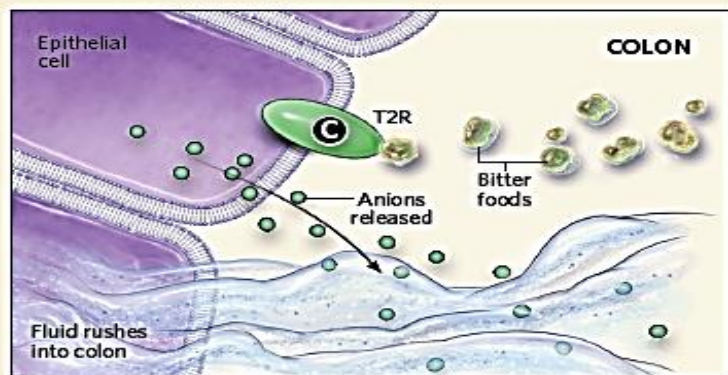

TASTE IN THE AIRWAYS

Scientists have also recently identified the existence of taste pathways in human airway cells, where they likely mediate defensive responses to inhaled foreign and potentially toxic substances.

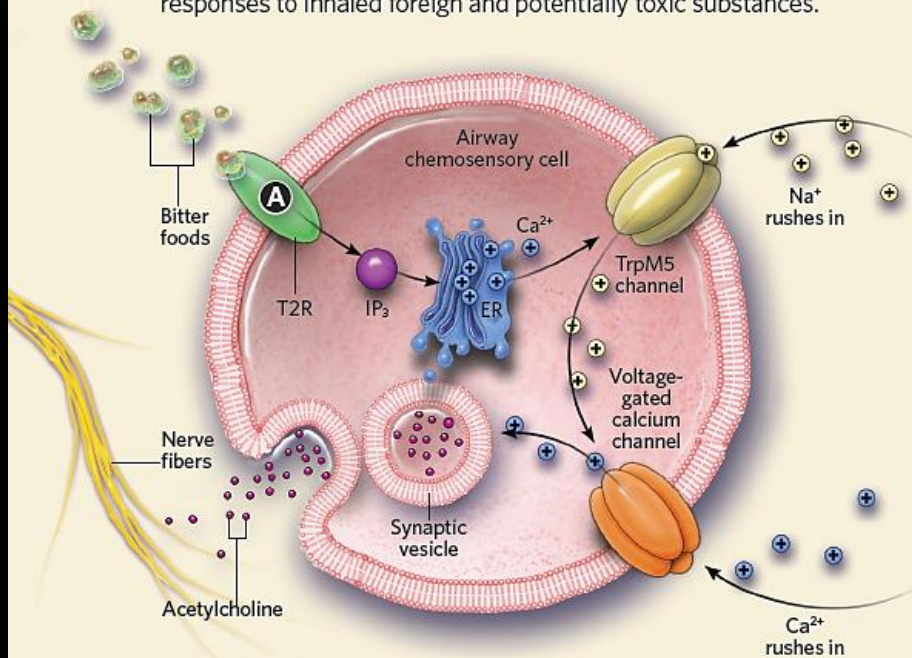

IN THE UPPER AIRWAY

In the upper airways (nasal passages and trachea), T2R receptors on chemosensory cells sense bitter compounds, releasing secondary messengers that spur the release of Ca^{2+} from the ER. The increase in cytoplasmic Ca^{2+} activates the TrpM5 transduction channel, allowing the influx of Na^+ and the depolarization of the cell. This in turn activates voltage-gated Ca^{2+} channels, which permit even more Ca^{2+} to flood into the cell. This initiates the fusion of synaptic vesicles with the plasma membrane, releasing the neurotransmitter acetylcholine to activate nearby nerve fibers and induce protective reflexes such as sneezing **A**.

IN THE LOWER AIRWAY

In airway smooth muscle cells of the lungs, the same T2R pathway is initiated by the binding of bitter compounds. Increases in cytoplasmic Ca^{2+} likely cause nearby calcium-activated potassium channels to open, allowing the outflow of K^+ , which causes hyperpolarization and subsequent relaxation of the muscle cells **B**. Also in the lungs, T2R receptors on ciliated airway epithelial cells bind bitter compounds, initiating the same G protein-mediated pathway that results in the release of Ca^{2+} from intracellular stores and thereby an increase in ciliary beat frequency, which researchers suspect serves to sweep irritants away from the surface of the cell **C**.

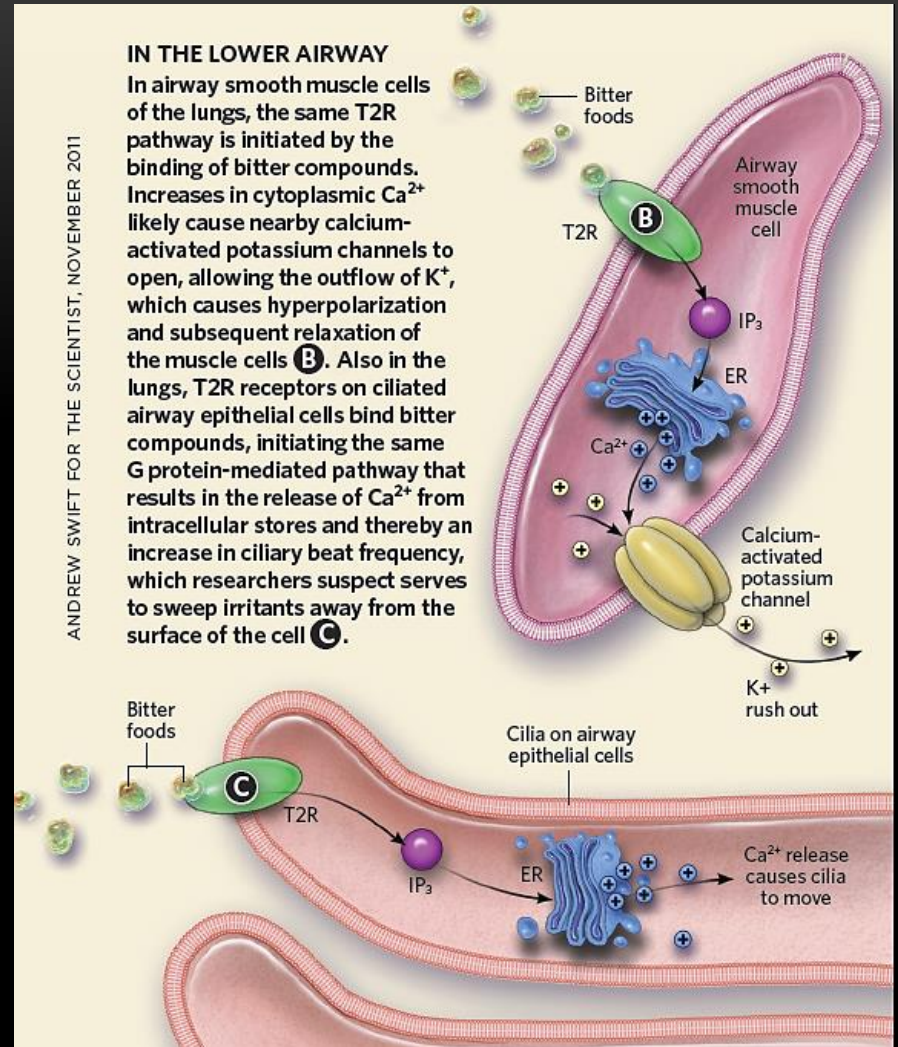

ANDREW SWIFT FOR THE SCIENTIST, NOVEMBER 2011

Matters of taste

Kde ještě jsou mimo ústní dutinu v těle člověka využity principy chuťové detekce?

Možná otázka

CHUŤ NA TUČNÉ

- CD36 – receptor na lipidy (?), scavenger receptor, v metabolismu lipidů, zánětu, hemostáze, ateroskleróze, řízení tlaku, při malárii sekvestrace Ery

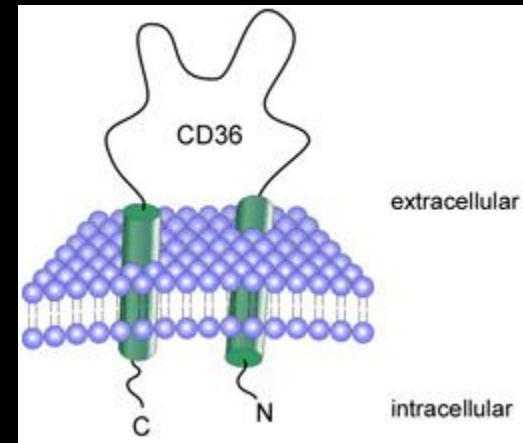

Metodika: Behaviorální chemorecepční testy – nasátí barvy, vysunutí sosáku, volba vůně

Figure 2. Assays of feeding behavior.

(A) Two-choice preference assay. Flies are first starved for a day and then provided with the choice of two chemicals, presented on a multi-well plate at specific concentrations in an agar medium. The two food substrates also contain different tasteless compounds that have intrinsic colors. For example, sucrose might be added in one half of the wells on a titer plate, along with the sulforhodamine B dye (red) and trehalose, along with an erioglaucine dye (blue) on the other half of the wells. The feeding is carried out in darkness (to exclude any influence of color preference) and the abdomen of the flies is inspected visually. The number of flies feeding on either substrate (red or blue abdomen) and both substrates (purple abdomen) are used to determine the feeding preference index: $PI(\text{sucrose}) = \frac{N(\text{red}) + 0.5N(\text{purple})}{N(\text{red}) + N(\text{blue}) + N(\text{purple})}$. (B) Proboscis extension reflex. This does not measure feeding behavior, but rather a reflex behavior associated with feeding. Starved flies are narcotized and immobilized and then let to awaken and recover. Upon satiation with water, the forelegs of the fly – the GRNs – are stimulated with a chemical and the number of proboscis extensions are counted over a short period directly following the stimulation. The proboscis is usually withdrawn (top), but upon stimulation of the foreleg with a feeding stimulus (for example a sugar solution), is frequently extended (bottom). The number of extensions is directly correlated with the attractiveness of the stimulus.

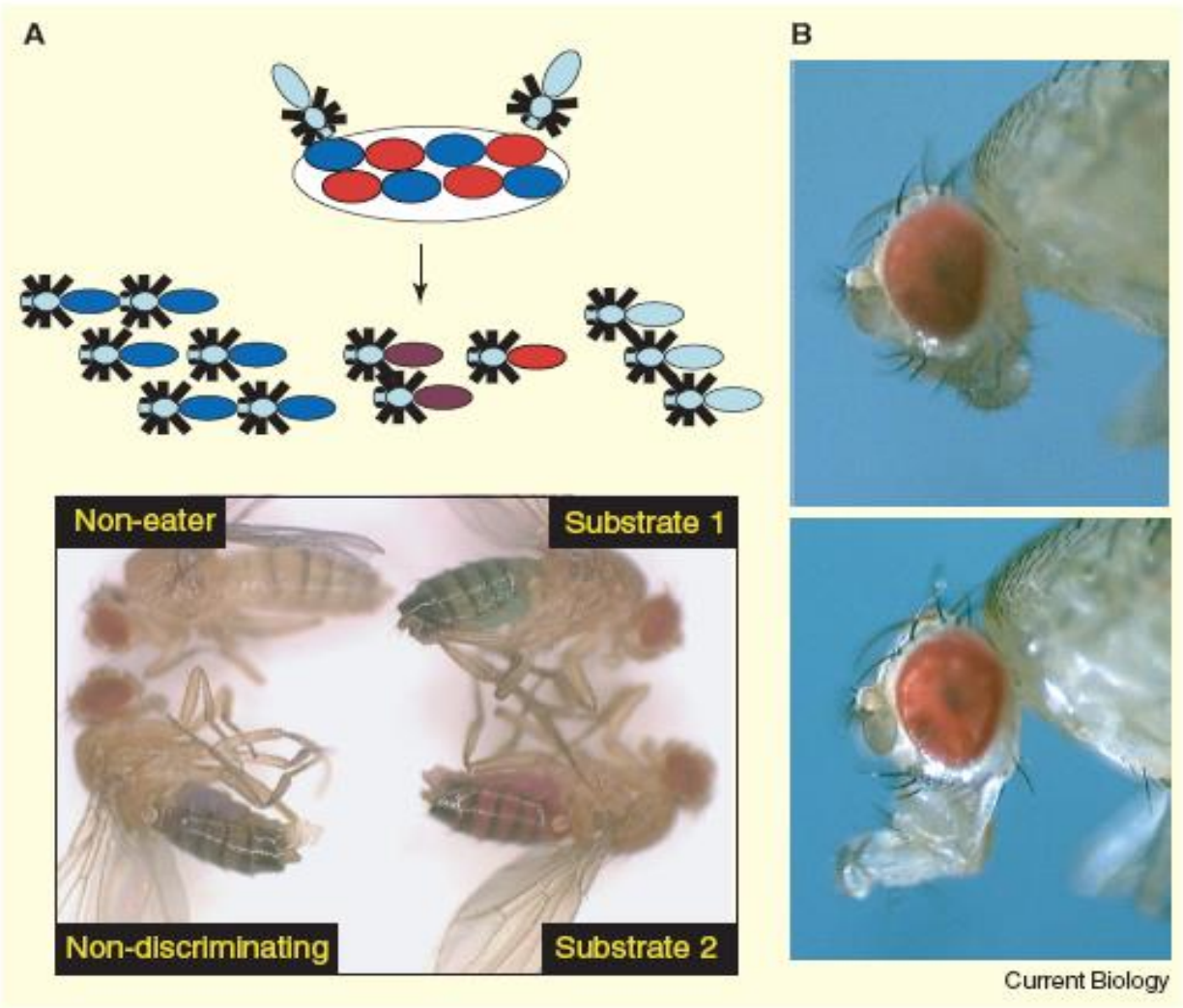

the GRNs – are stimulated with a chemical and the number of proboscis extensions are counted over a short period directly following the stimulation. The proboscis is usually withdrawn (top), but upon stimulation of the foreleg with a feeding stimulus (for example a sugar solution), is frequently extended (bottom). The number of extensions is directly correlated with the attractiveness of the stimulus.

MECHANORECEPCE – HMAT, SLUCH



Mechanorecepce může přímo řídit expresi bez zprostředkování kanálem Např. růst svalů

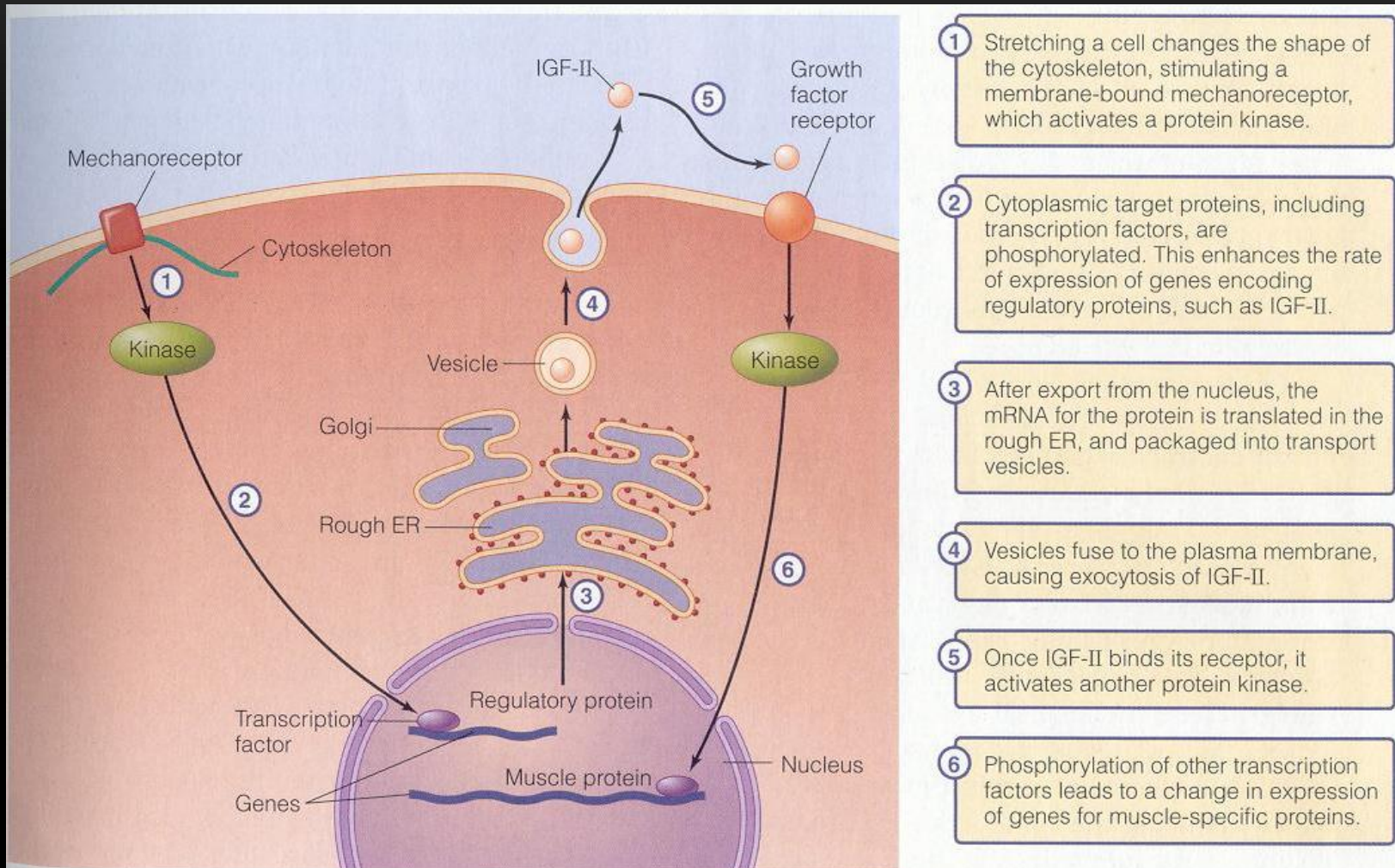
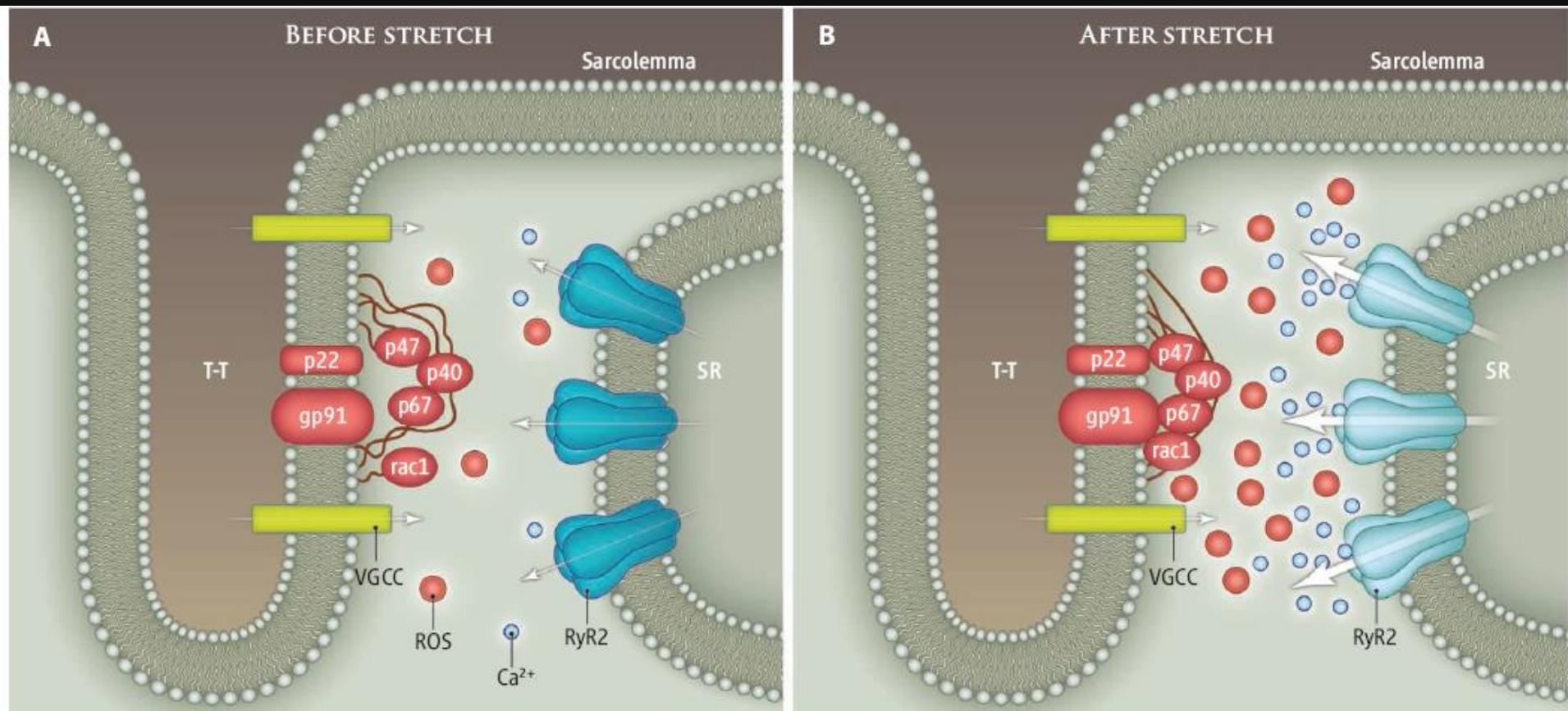

Figure 5.33 Control of gene expression by stretch receptors Some muscle cells sense the degree of stretch and respond by a cascade initiated by stretch receptors and culminating in changes in muscle gene expression.

... nebo uvolňování chemických signálů řídících srdeční činnost. Mechanické napětí přenášeno na cytoskelet a možná přímo mění enzymatickou aktivitu vázaného signálního komplexu.



X-ROS signaling. In heart muscle cells, transverse tubule (T-T) membranes contain voltage-gated Ca²⁺ channels (VGCC, green). Influx of Ca²⁺ through the channels generates signals that open RyR2 channels (blue) in the neighboring sarcoplasmic reticulum (SR); the ensuing Ca²⁺ release promotes cell contraction. The T-T membrane also contains the NOX2 subunits p22 and gp91 (red). Before stretch (A), NOX2 activity, production of ROS (red dots), and Ca²⁺ sparks (blue

dots) are low. A moderate stretch (B) causes an immediate activation of NOX2 by recruiting its regulatory subunits (p40, p47, p67, and rac1) to the T-T membrane via a mechanism that requires intact microtubules. The resulting increase in ROS production sensitizes RyR2 to activation by Ca²⁺, presumably by changing RyR2 redox state, causing a burst of Ca²⁺ sparks. Returning the cell to its initial length returns X-ROS signaling to its initial state. [Figure adapted from (2)]

Tkáňově specifická diferenciacie: exprese pod mechanickým řízením. Cellular mechanosensation

Cells can both sense and dictate the physical properties of their microenvironment while preserving the structural continuity within the surrounding tissue. Consequently, tissues acquire stiffness optima as an emergent property of the physical and biochemical interactions between their constituent cells. This tensional equilibrium confers macroscopic compliance properties that are critical for processes such as stem cell differentiation, embryonic development, and tissue homeostasis.

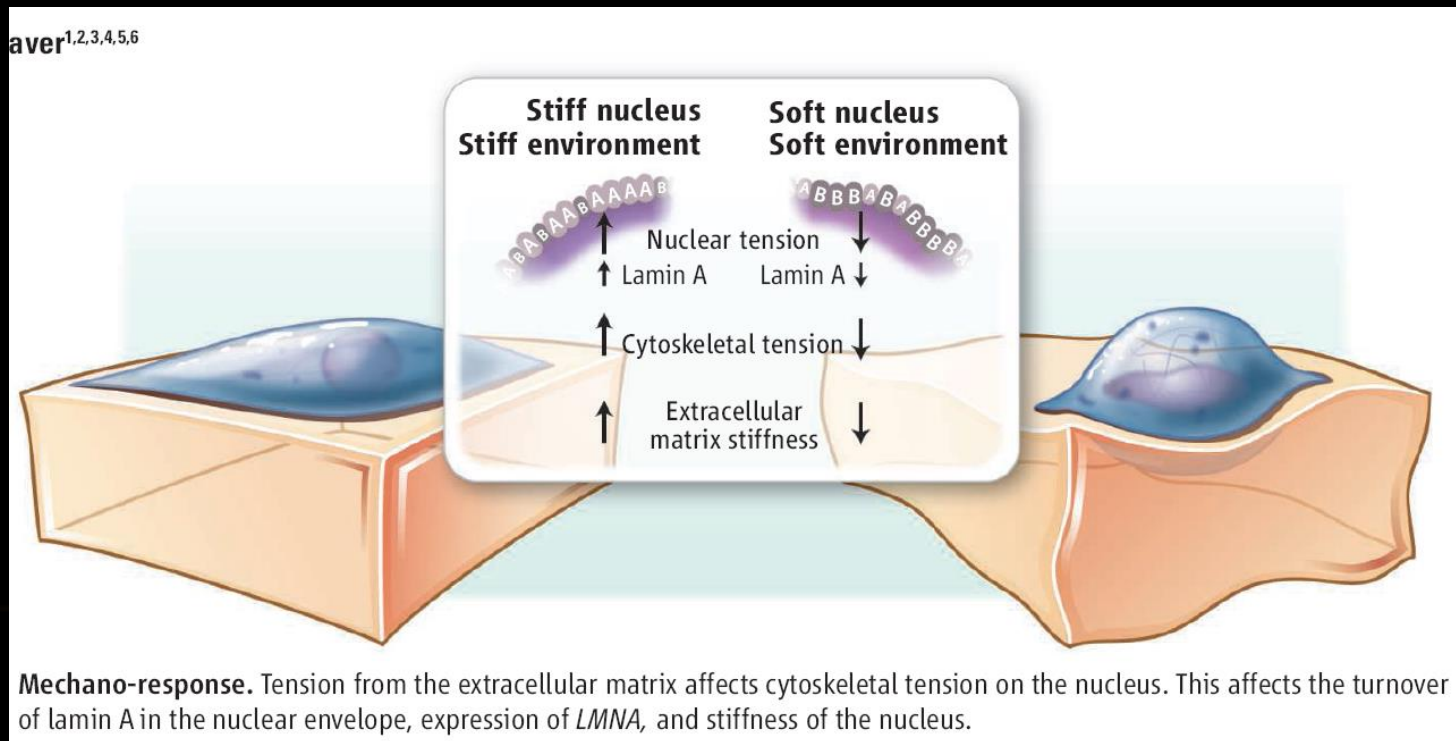

Sluch, hmat, rovnováha,
osmorecepce, hygromorecepce

Zrychlení
Magnetorecepce?

Dlouho neznámý mol. mechanismus

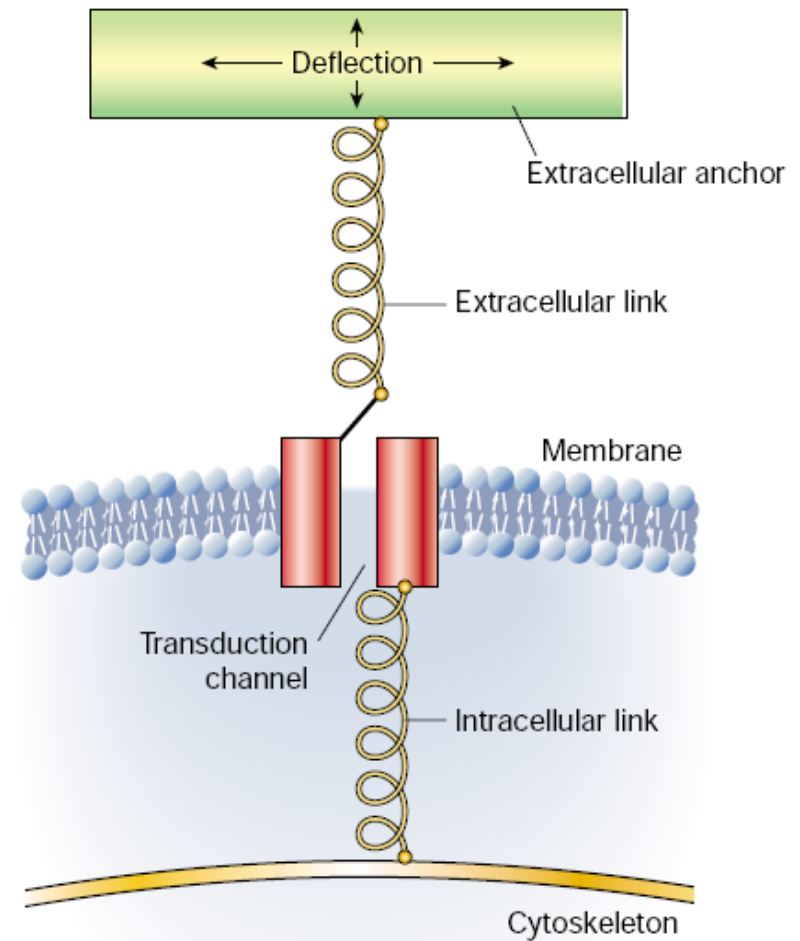
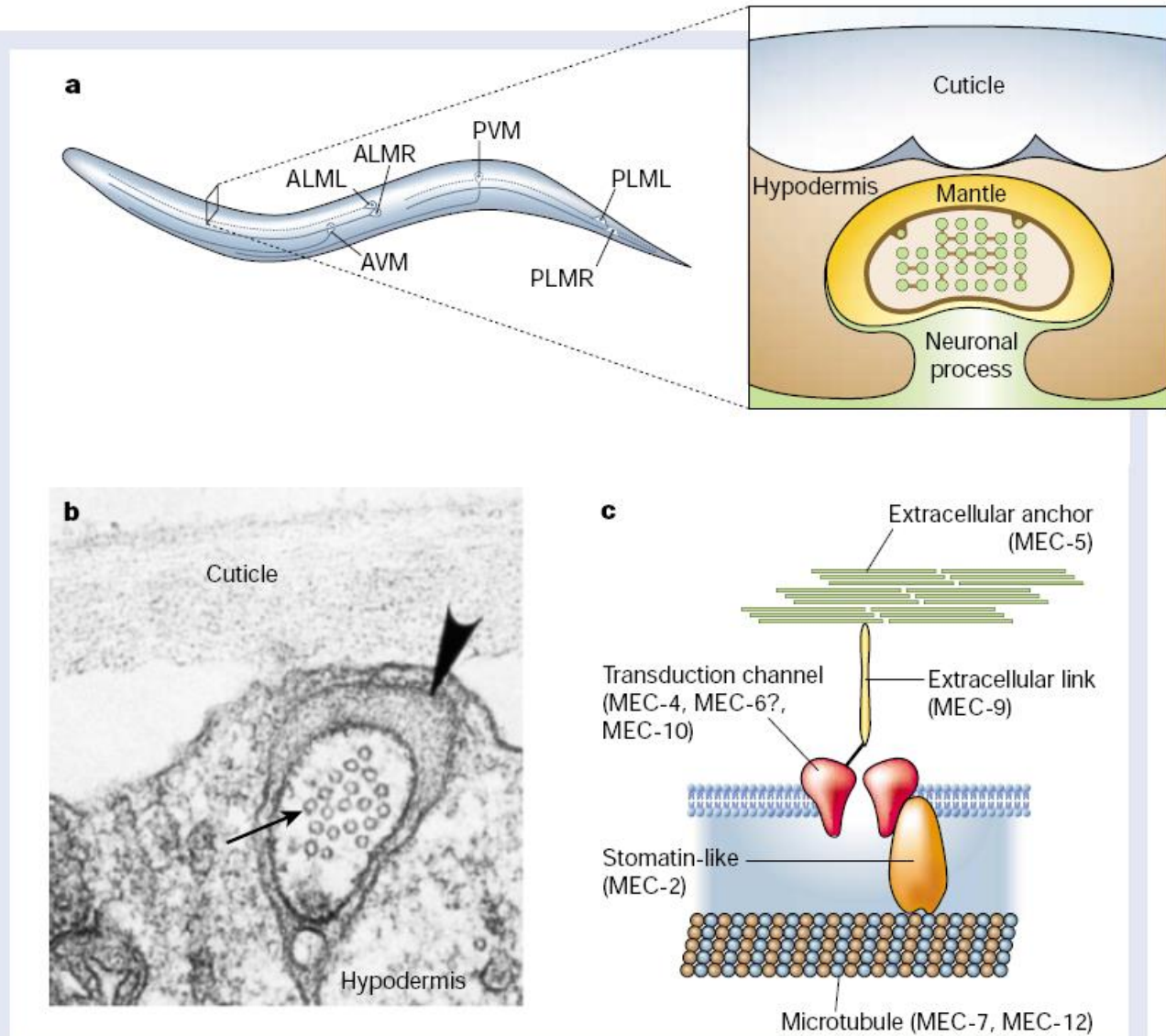

Figure 1 General features of mechanosensory transduction. A transduction channel is anchored by intracellular and extracellular anchors to the cytoskeleton and to an extracellular structure to which forces are applied. The transduction channel responds to tension in the system, which is increased by net displacements between intracellular and extracellular structures.

Modelový organismus háďátka

Figure 2 *C. elegans* touch-receptor structure and transduction model. **a**, View of *C. elegans* showing positions of mechanoreceptors. AVM, anterior ventral microtubule cell; ALML/R, anterior lateral microtubule cell left/right; PVM, posterior ventral microtubule cell; PLML/R, posterior lateral microtubule cell left/right. **b**, Electron micrograph of a touch-receptor neuron process. Mechanotransduction may ensue with a net deflection of the microtubule array relative to the mantle, a deflection detected by the transduction channel. Arrow, 15-protofilament microtubules; arrowhead, mantle. Modified from ref. 3. **c**, Proposed molecular model for touch receptor. Hypothetical locations of *mec* proteins are indicated.



Modelový organismus octomilka

Figure 3 *Drosophila* bristle-receptor model.

a, Lateral view of *D. melanogaster* showing the hundreds of bristles that cover the fly's cuticle. The expanded view of a single bristle indicates the locations of the stereotypical set of cells and structures associated with each mechanosensory organ. Movement of the bristle towards the cuticle of the fly (arrow) displaces the dendrite and elicits an excitatory response in the mechanosensory neuron. **b**, Transmission electron micrograph of an insect mechanosensory bristle showing the insertion of the dendrite at the base of the bristle. The bristle contacts the dendrite (arrowhead) so that movement of the shaft of the bristle will be detected by the neuron. **c**, Proposed molecular model of transduction for ciliated insect mechanoreceptors, with the locations of NompC and NompA indicated.

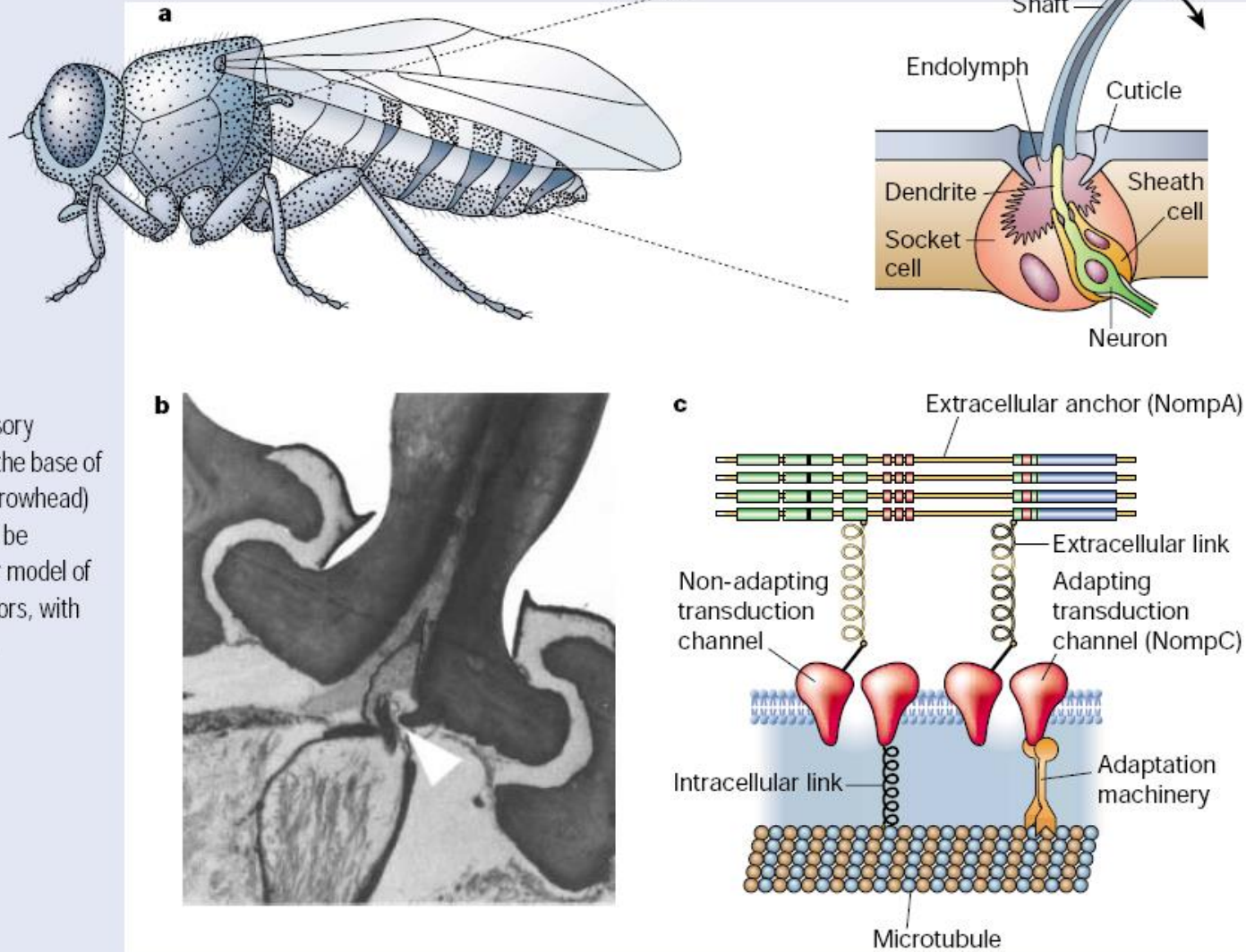

Mutanti byli necitliví na dotyk. Podobně i mutanti drosophil. Larvy, které nebyly citlivé na dotek, byly v dospělosti hluchými mouchami s nekoordinovanými pohyby. Princip je zřejmě dosti konzervovaný a obecný pro různé aplikace mechanorecepce. Mutace se týkaly kotev na jedné nebo druhé straně membrány nebo kanálu samotného. Kanál opět patří do rodiny TRP.

Hád'átko essay



Savčí mechanorecepce sluchu

Figure 4 Inner-ear structure and hair-cell transduction model. **a**, Gross view of part of the inner ear. Sound is transmitted through the external ear to the tympanic membrane; the stimulus is transmitted through the middle ear to the fluid-filled inner ear. Sound is transduced by the coiled cochlea. **b**, Cross-section through the cochlear duct. Hair cells are located in the organ of Corti, resting on the basilar membrane. **c**, Sound causes vibrations of the basilar membrane of the organ of Corti; because flexible hair-cell stereocilia are coupled to the overlying tectorial membrane, oscillations of the basilar membrane cause back-and-forth deflection of the hair bundles. **d**, Scanning electron micrograph of hair bundle (from chicken cochlea). Note tip links (arrows). **e**, Proposed molecular model for hair-cell transduction apparatus.

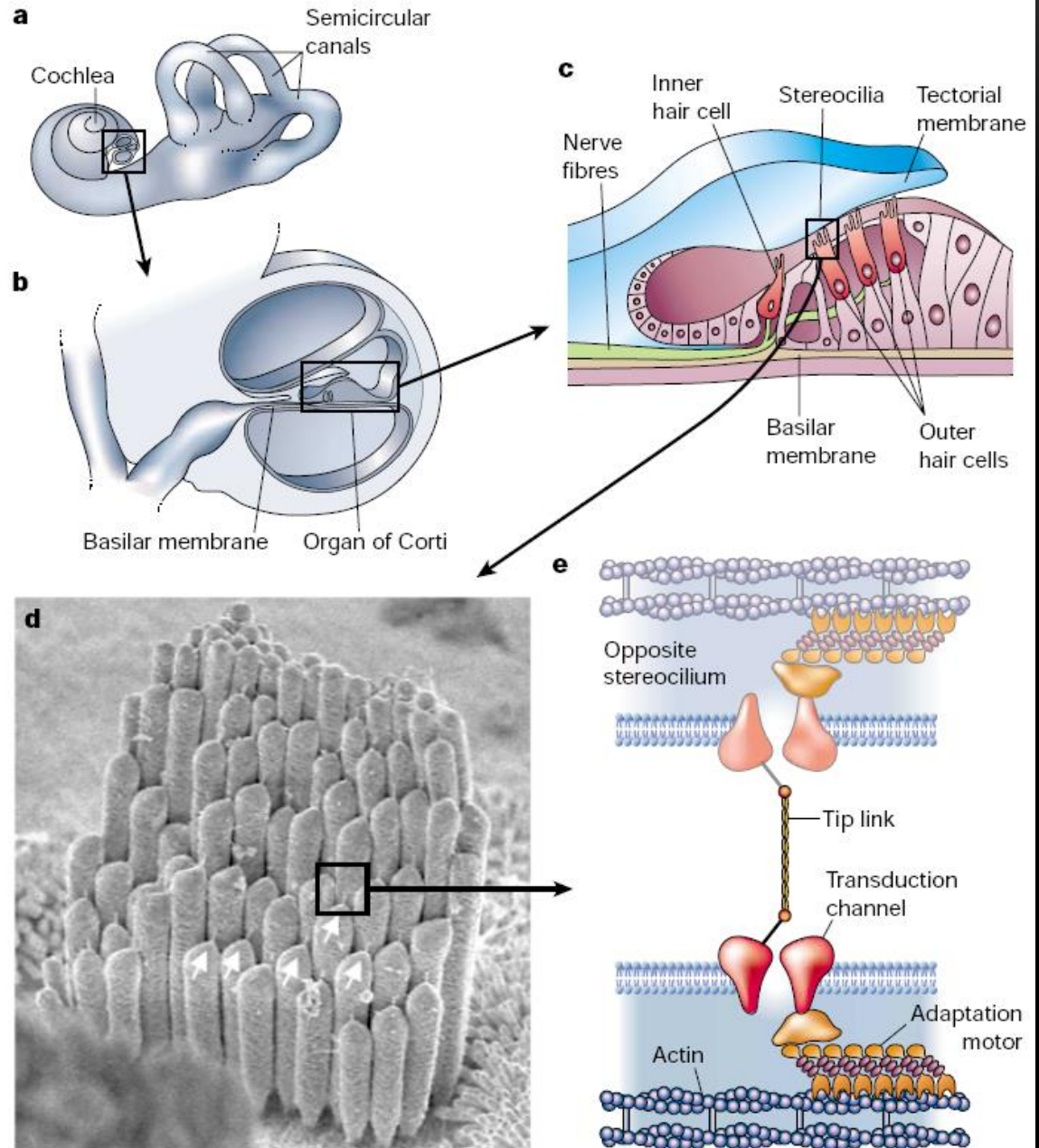

Rychlá a pomalá adaptace:

- Aktivní pohyb v rytmu (zesílení)
- Nastavení napětí spoje (adaptace)

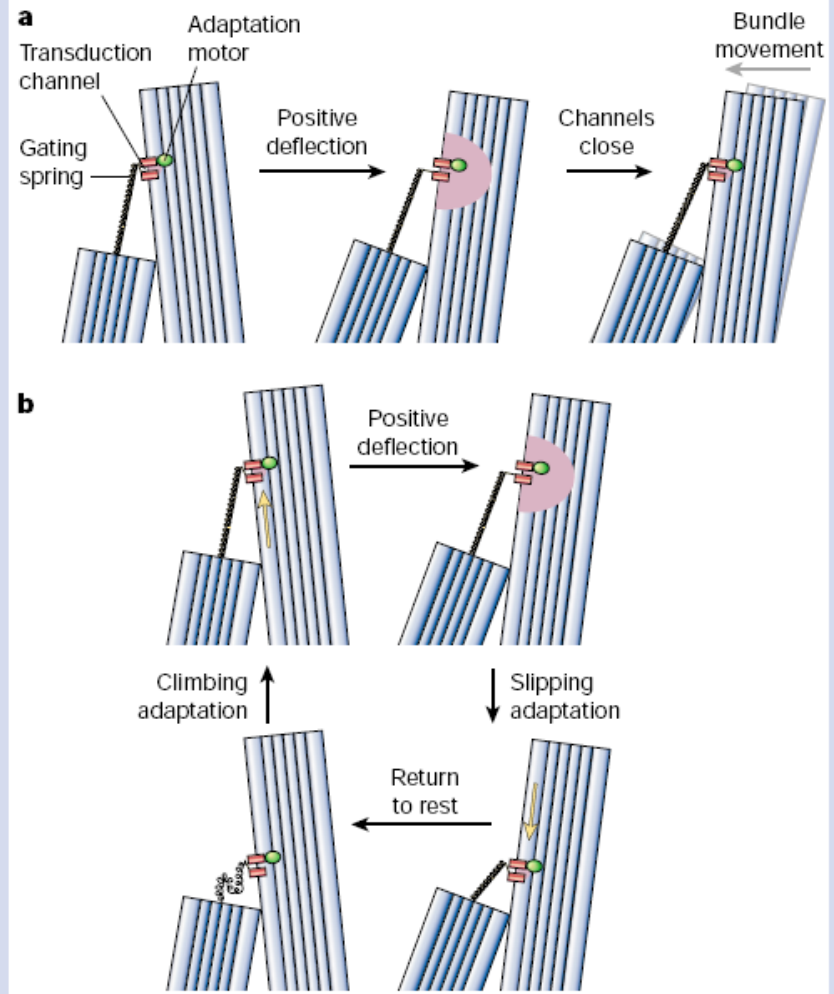

Box 2 Figure Hair-cell transduction and adaptation. **a**, Transduction and fast adaptation. At rest (left panel), transduction channels spend ~5% of the time open, allowing a modest Ca^{2+} entry (pink shading). A positive deflection (middle) stretches the gating spring (drawn here as the tip link); the increased tension propagates to the gate of the transduction channel, and channels open fully. The resulting Ca^{2+} flowing in through the channels shifts the channels' open probability to favour channel closure (right). As the gates close, they increase force in the gating spring, which moves the bundle back in the direction of the original stimulus. **b**, Transduction and slow adaptation. Slow adaptation ensues when the motor (green oval) slides down the stereocilium (lower right), allowing channels to close. After the bundle is returned to rest (lower left), gating-spring tension is very low; adaptation re-establishes tension and returns the channel to the resting state.

Mechanosensitivita TRP

Hádčátko se nevyhýbalo doteku,
ani škodlivým látkám

Drosophila hluchá a špatně chodící

3 možné mechanismy:

- a) Tenze membrány
- b) Tenze kotvy cytoskeletu
- c) Změna aktivity enzymu

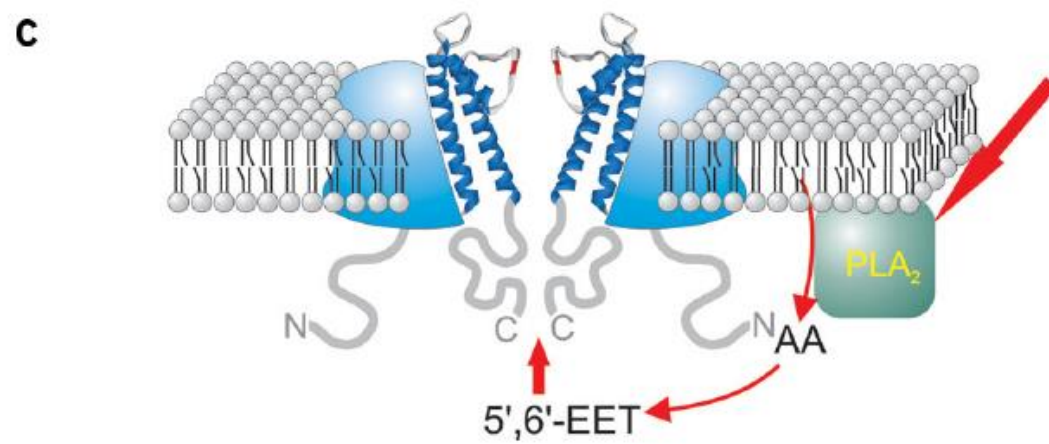
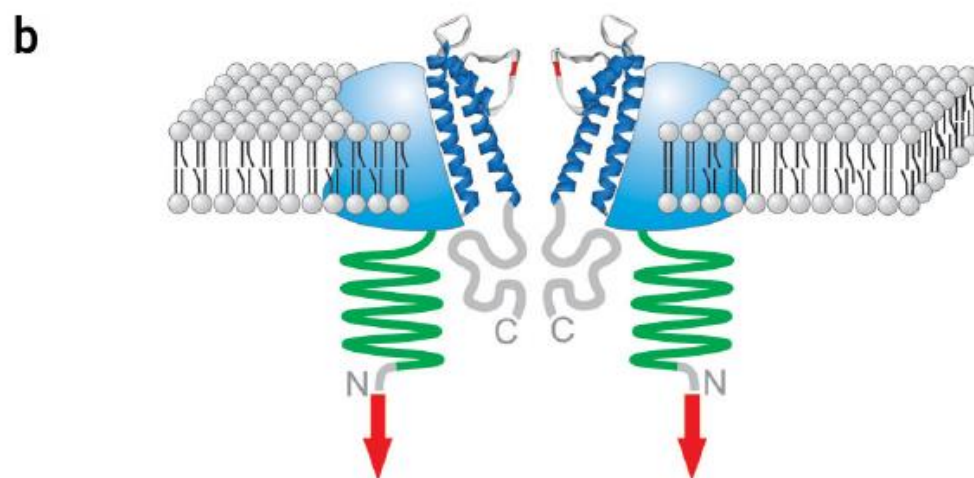
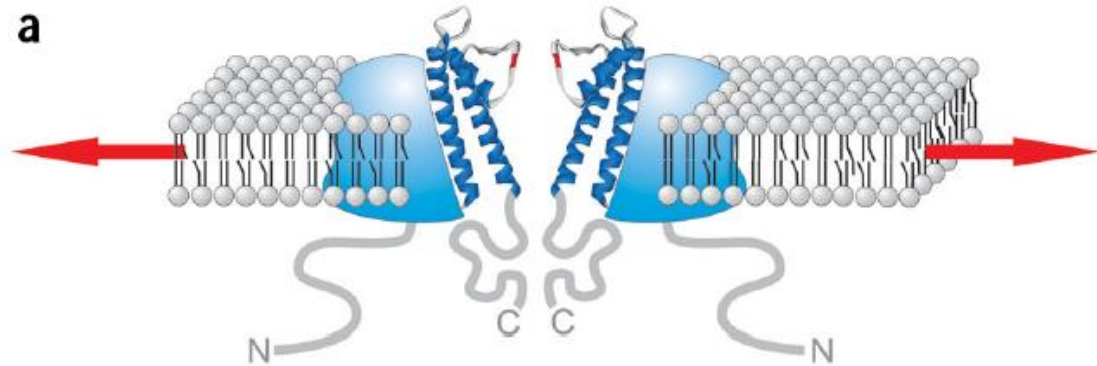

Jaký je molekulární mechanismus mechanorecepce?

Kde se molekulární mechanismy mechanorecepce uplatňují mimo klasické smysly?

Možná otázka

NOCICEPCE – VNÍMÁNÍ BOLESTI



V případě zraku nebo čichu potřebují primární neurony jediný druh stimulu. Nocicepce je jiná v tom, že primární neurony dráhy bolesti mají schopnost detekovat širokou škálu modalit včetně chemické a fyzikální povahy. Musí být tedy vybavena rozmanitým repertoárem transdukčních zařízení.

Na rozdíl od zraku chuti nebo čichu nejsou nervová zakončení pro bolest lokalizována v nějaké anatomické struktuře, ale jsou rozptýlena po celém těle, v kůži, svalech, kloubech vnitřních orgánech.

Jsou různé typy vláken, o kterých se předpokládá, že vedou různou rychlostí a zprostředkovávají akutní, ostrou prudkou bolest a jiná difúzní, pozdní bolest tupou.

Receptory jsou obvykle polymodální, odpovídající jak na teplotu, tak na mechanické a chemické stimuly a na poranění tkáně. Odpověď na horko je jednou z nejprostupovanějších bolestivých odpovědí.

Na rozdíl od čichu nebo fotorecepce polymodalita nociceptorů – chemické, fyzikální i teplotní stimuly

Receptory jsou rozptýleny po celém těle

Figure 2 Polymodal nociceptors use a greater diversity of signal-transduction mechanisms to detect physiological stimuli than do primary sensory neurons in other systems. **a**, In mammals, light or odorants are detected by a convergent signalling pathway in which G-protein-coupled receptors modulate the production of cyclic nucleotide second messengers, which then alter sensory neuron excitability by regulating the activity of a single type of cation channel. **b**, In contrast, nociceptors use different signal-transduction mechanisms to detect physical and chemical stimuli. Recent studies suggest that TRP-channel family members (VR1 and VRL-1) detect noxious heat, and that ENaC/DEG-channel family detect mechanical stimuli. Molecular transducers for noxious cold remain enigmatic. Noxious chemicals, such as capsaicin or acid (that is, extracellular protons) may be detected through a common transducer (VR1), illustrating aspects of redundancy in nociception. At the same time, a single type of stimulus can interact with multiple detectors, as shown by the ability of extracellular protons to activate not only VR1, but also ASICs, which are also members of the ENaC/DEG-channel family.

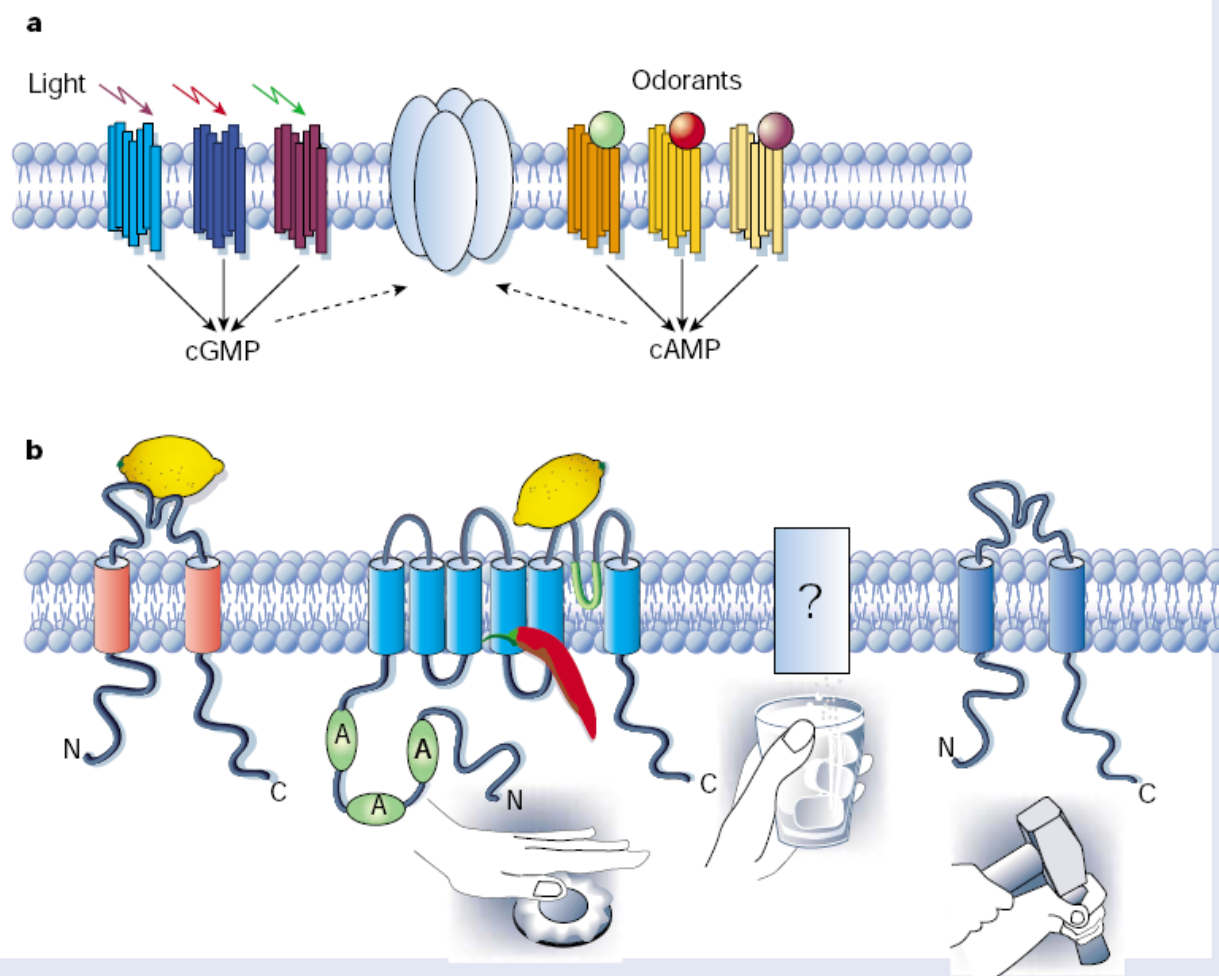

Jste li u zubaře a necháte-li si aplikovat anestezi, anestetika blokují všechny napěťově řízené sodíkové kanály. To zablokuje jakékoliv cití a i motorické funkce. Nyní však byly objeveny sodíkové kanály, které jsou pouze v neuronech vnímajících bolest. To je výzva pro farmaceutické laboratoře, aby našly „kouzelnou kulku“ selektivně na ně.

TRPV1 kanál, který je otevírán kapsaicinem, nebo teplotami nad 42°C se vyskytuje pouze na nociceptorech! Takže jeho blokáda způsobí anestezii bez paralýzy.

MAGNETORECEPCE

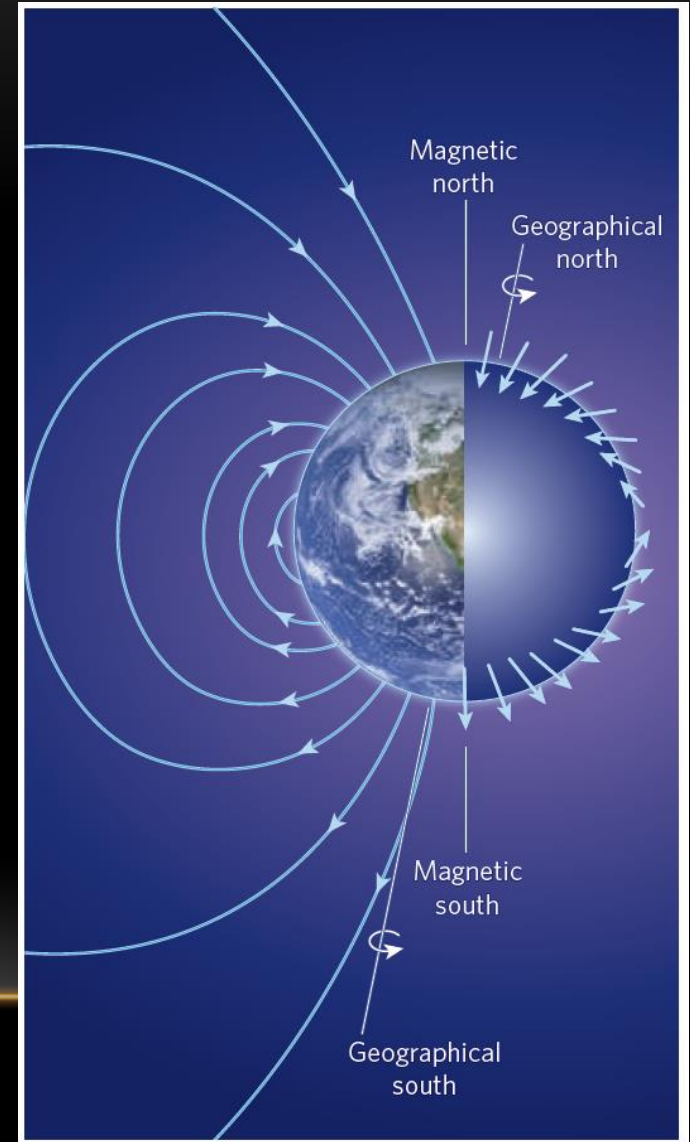

Varianta mechanorecepce- Magnetit?



$B = 0$

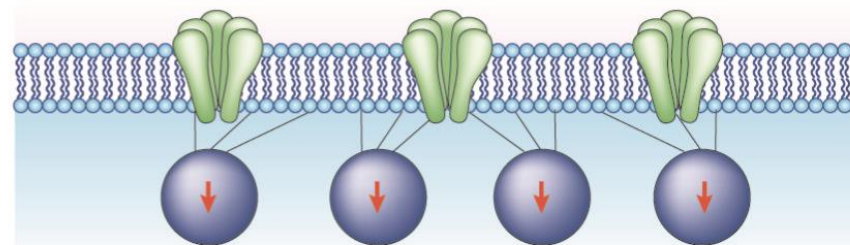
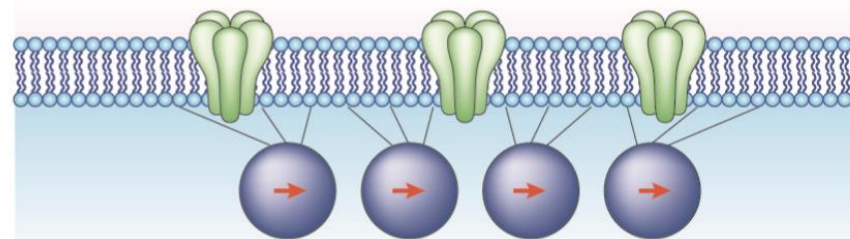
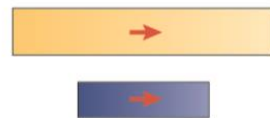
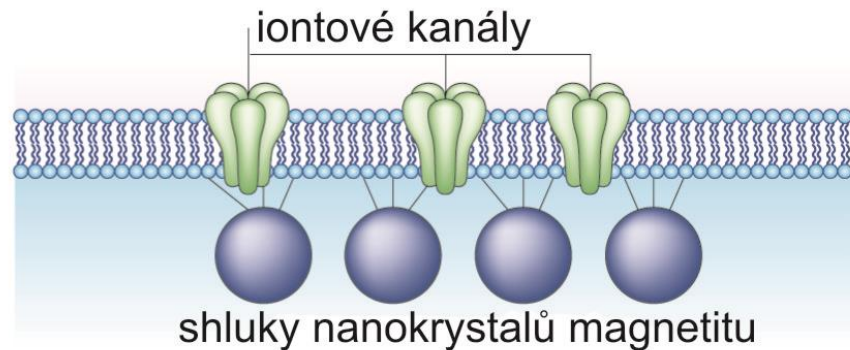

Varianta mechanorecepce- Magnetit?

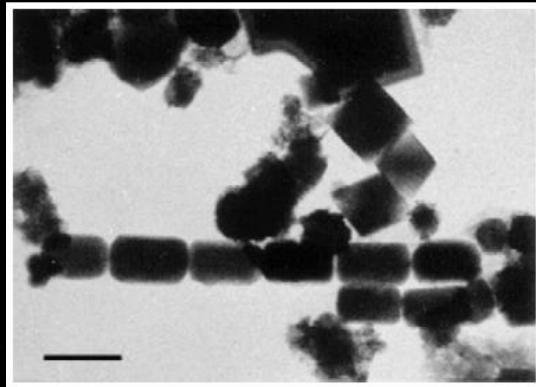
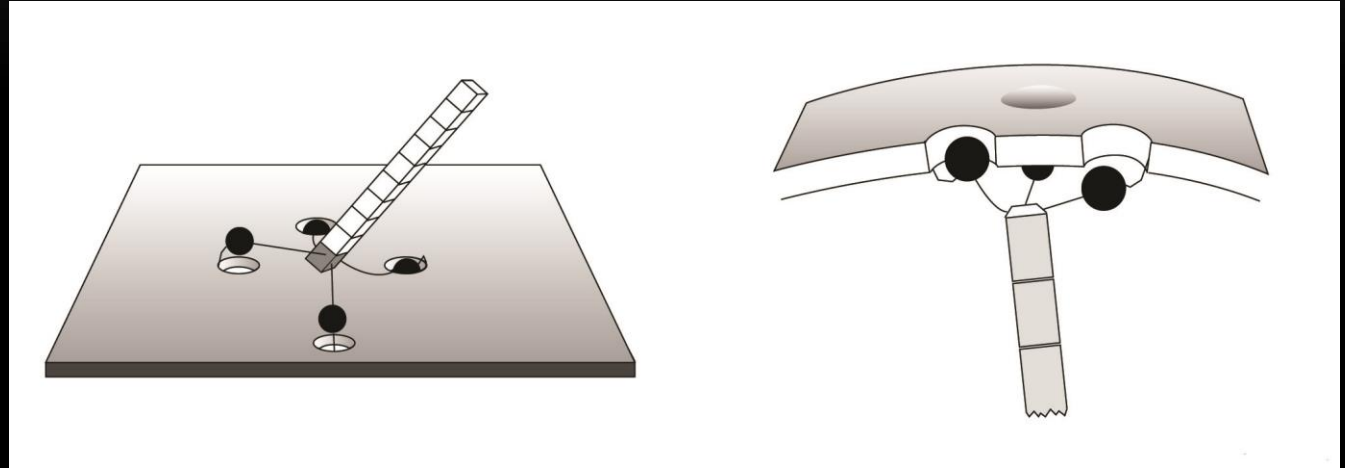

Varianta mechanorecepce- Magnetit?

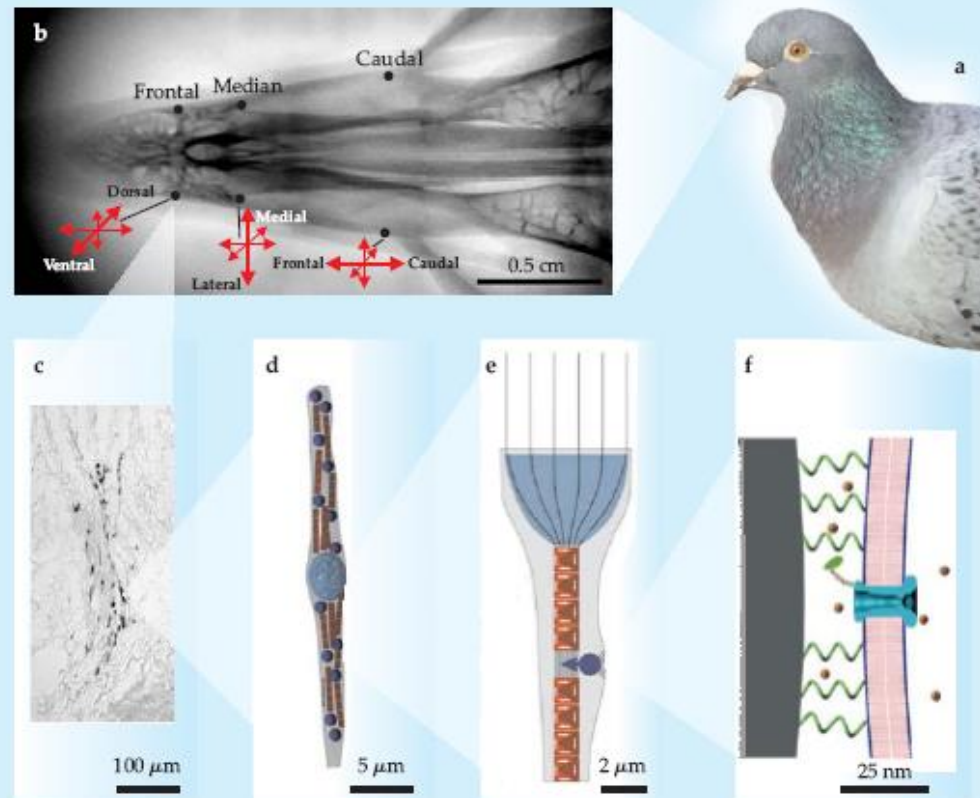
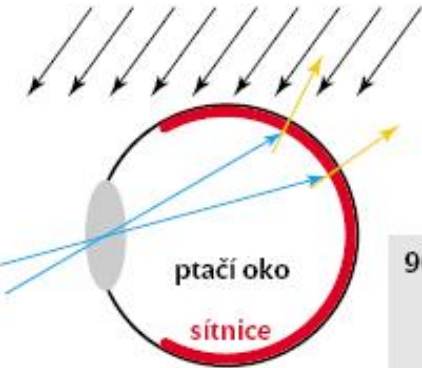

Figure 4. Evidence for magnetite-based magnetoreception. (a) The homing pigeon *Columba livia* provides some of the best evidence. (b) X-ray image of the upper beak of *C. livia*, showing the three pairs of iron-containing areas and the prevailing orientations of their neurons. (c) Stained section of the dendritic region in one of the areas. Dark areas are iron deposits. (d) Schematic of a single neuron, showing the centrally located, iron-coated vesicle (light blue) and the clusters of magnetite crystals (dark blue) alternating with rows of maghemite plates (red). (e) Hypothesized concentration of magnetic flux in a neuron and its effect on the position of one of the magnetite clusters. (f) Magnetite cluster pulling away from a membrane, which bends and opens a mechanically stimulated ion channel. (Panel a courtesy of Andreas Trepte; panels b–c adapted from G. Fleissner et al., *Naturwissenschaften* **94**, 631, 2007; panels d–e adapted from G. Fleissner et al., *J. Ornithol.* **148**, 643, 2007; panel f adapted from I. Solov'yov, W. Greiner, *Biophys. J.* **93**, 1493, 2007.)

VARIANTA FOTORECEPCE?



7. Vlevo nahoře je schéma oka obratlovce. Fotoreceptory jsou v různých částech sítnice různě orientovány vůči magnetickému poli (orientace fotoreceptorů znázorněna žlutými, orientace magnetického vektoru černými šipkami). Vlevo dole je počítačová simulace zrakových vjemů modulovaných magnetickým polem.

Vnímané vzory se mění v závislosti na orientaci zvířete vzhledem k vektoru magnetického pole. Vpravo je idealizovaná představa – tak nějak může pták vnímat krajinu, nad kterou letí. Podle: Ritz a kol., Biophys. J. 78, 707–718, 2000.

Snímek pobřeží Sardinie © Stanislav Vaněk.

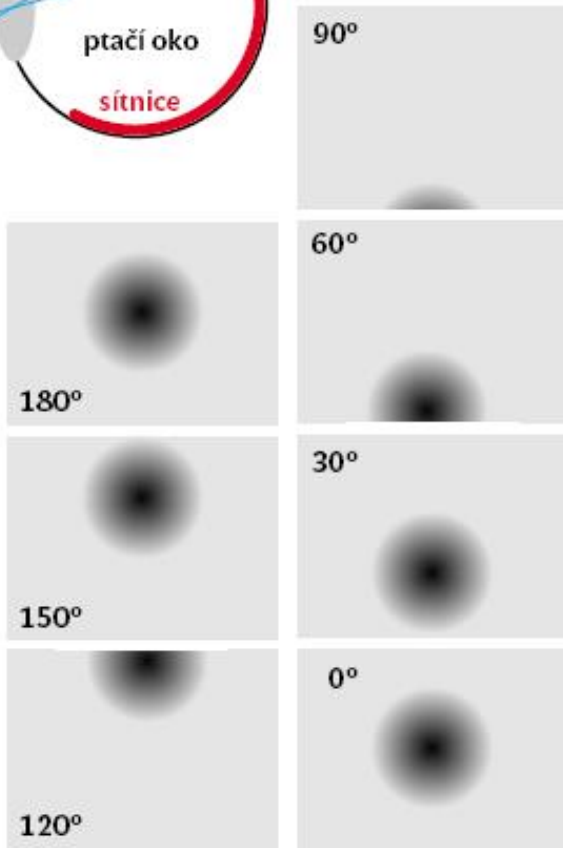

Fotochemický model založený na reakcích radikálových párů.

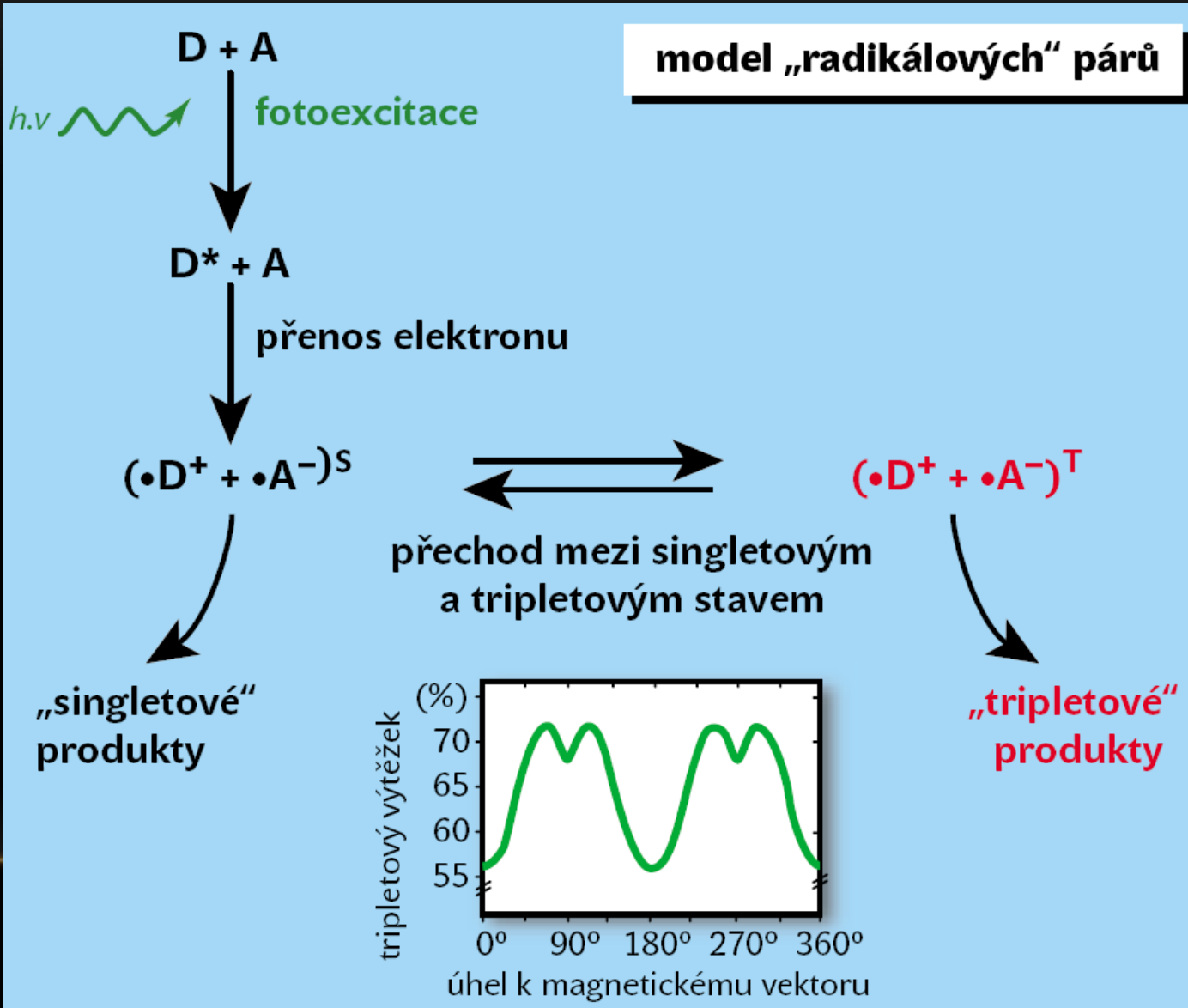

Energie

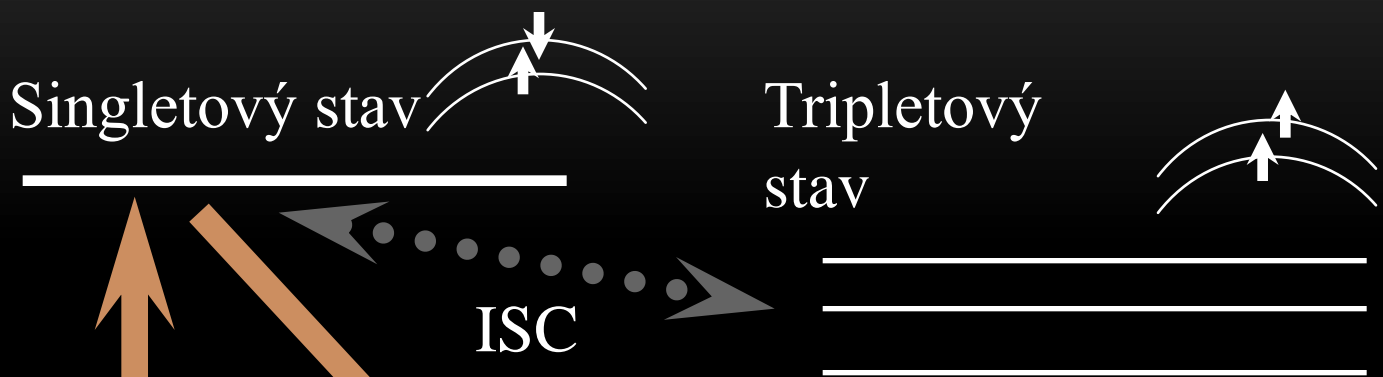

Singletový stav

Tripletový stav

ISC

rozpad

excitace fotonem

recepce světla

únik do dalších reakcí

Opsin-cis retinal v základním stavu

Trans retinal + opsin

Spontánní oscilace mezi dvěma stavy.

Posun v pravděpodobnosti výtěžku reakce.

Magnetická síla

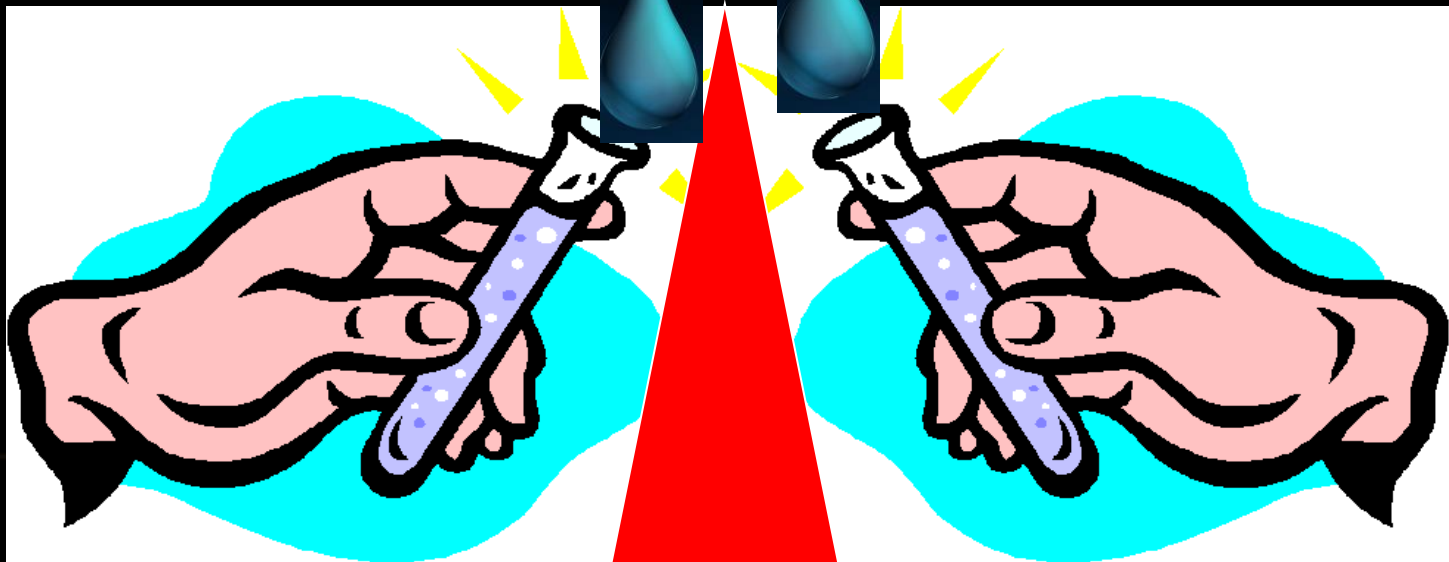
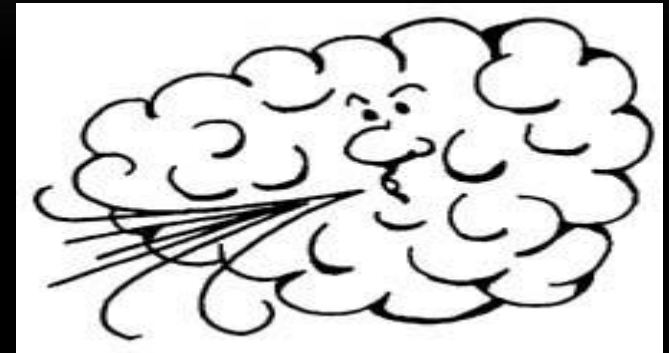

Kryptochromy:

- Nejpravděpodobnější kandidáti na magnetoreceptor zrakové dráhy.
- Signální proteiny zvířat i rostlin, homologní DNA fotolyázám.
- Součástí biologických hodin.

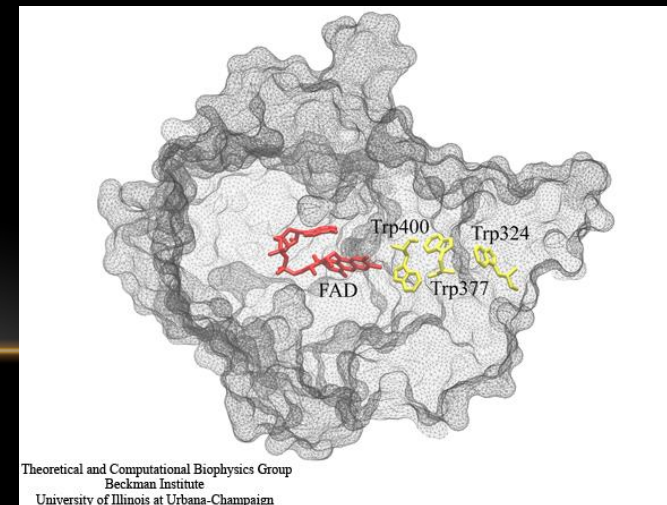

Kryptochromy:

Radikálový pár tvoří FAD (akceptor e-) a tryptofan (donor e-).

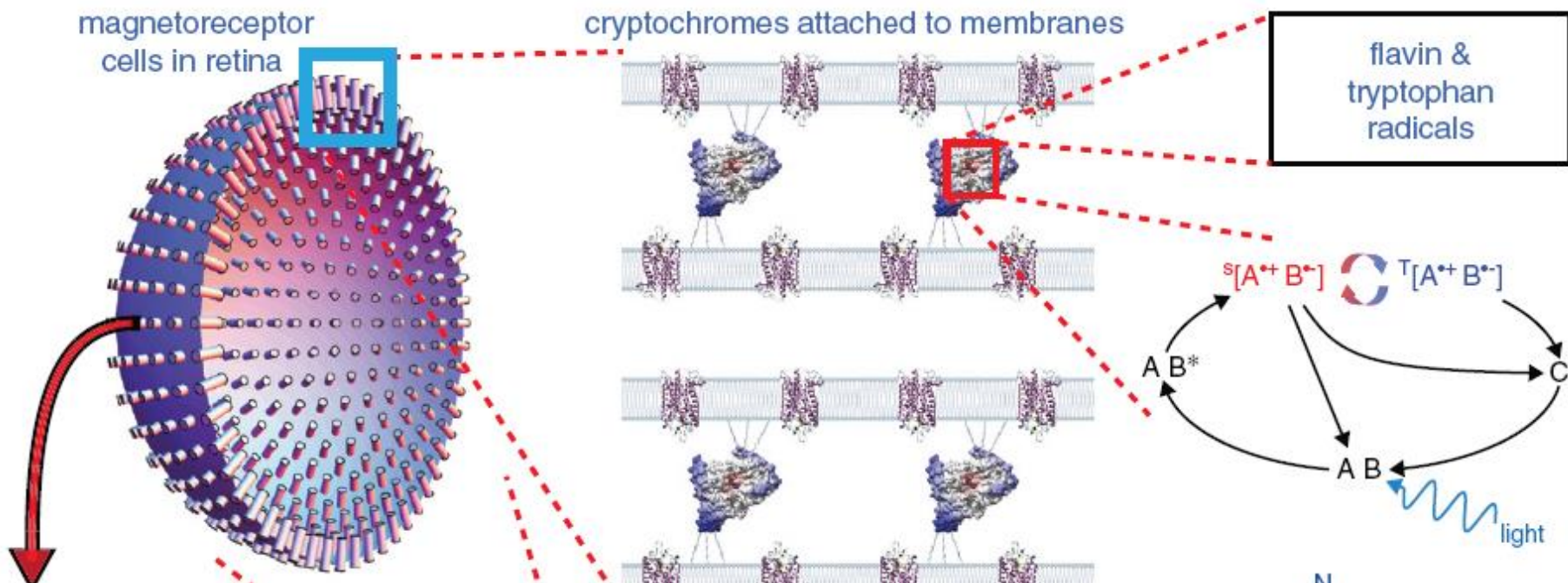

Kryptochromy:

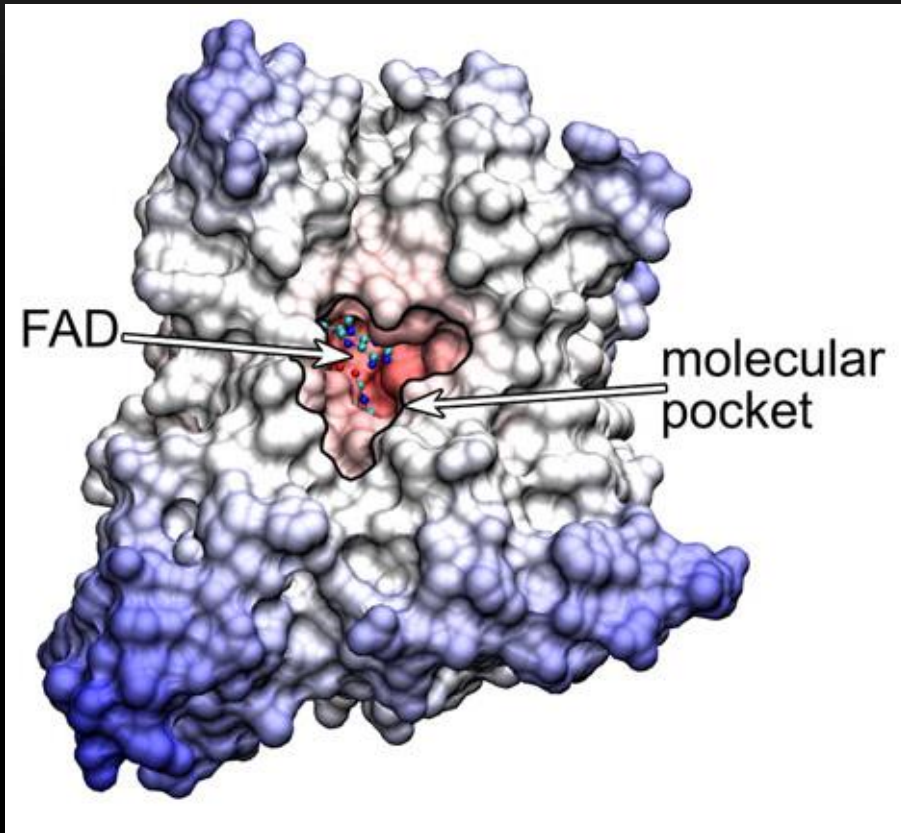

<http://www.ks.uiuc.edu/Research/cryptochrome/>

Flavinový kofaktor obsazuje molekulární kapsu kryptochromu a tvoří radikálový pár $[FAD^{\circ-} + TrpH^{\circ+}]$, který se nachází v singletovém (25 %) nebo tripletovém (75 %) stavu.

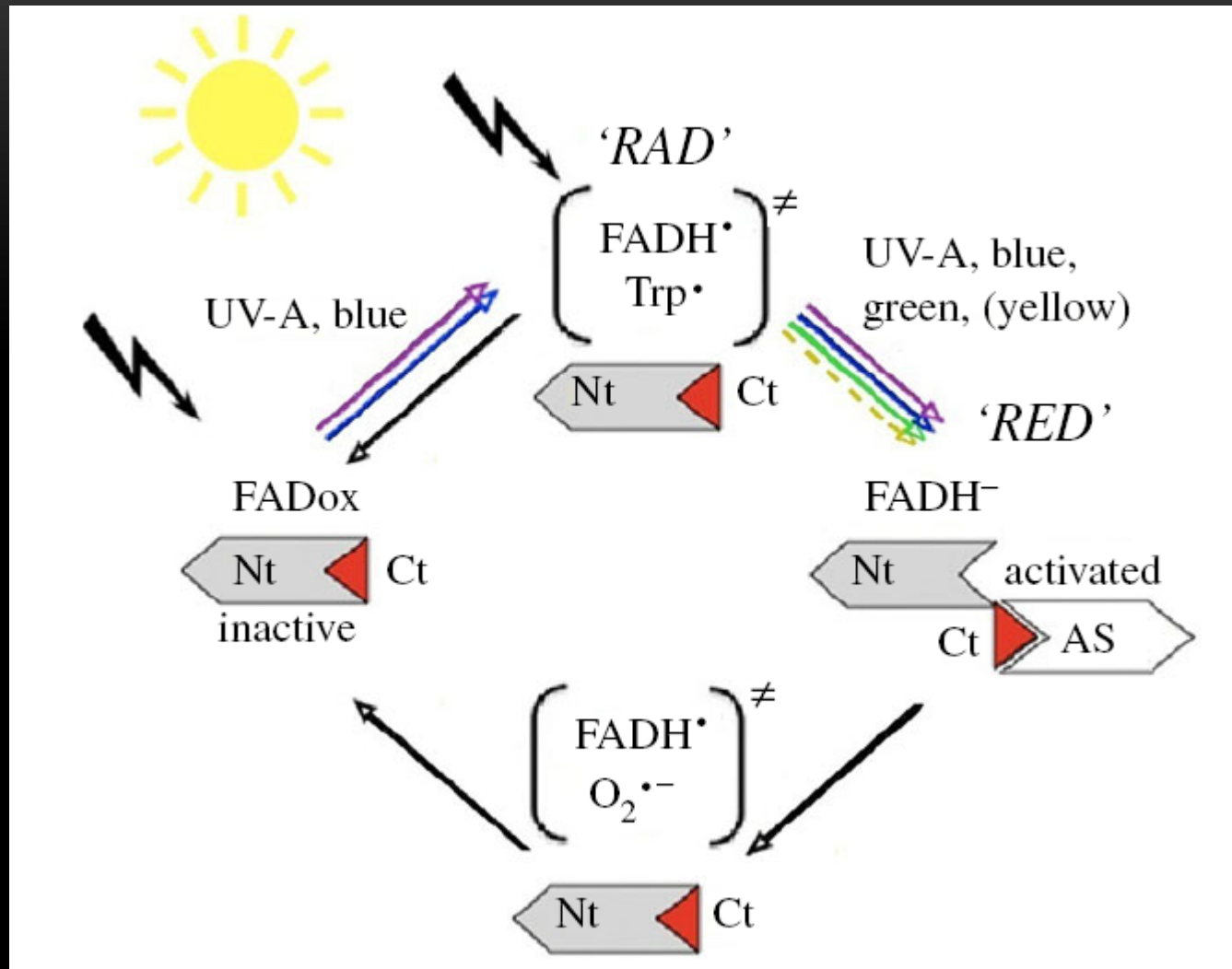

Nt (N-konec) CRY a signální Ct (konec) CRY
 Setrvání CRY v aktivovaném stavu ovlivní signalizaci.

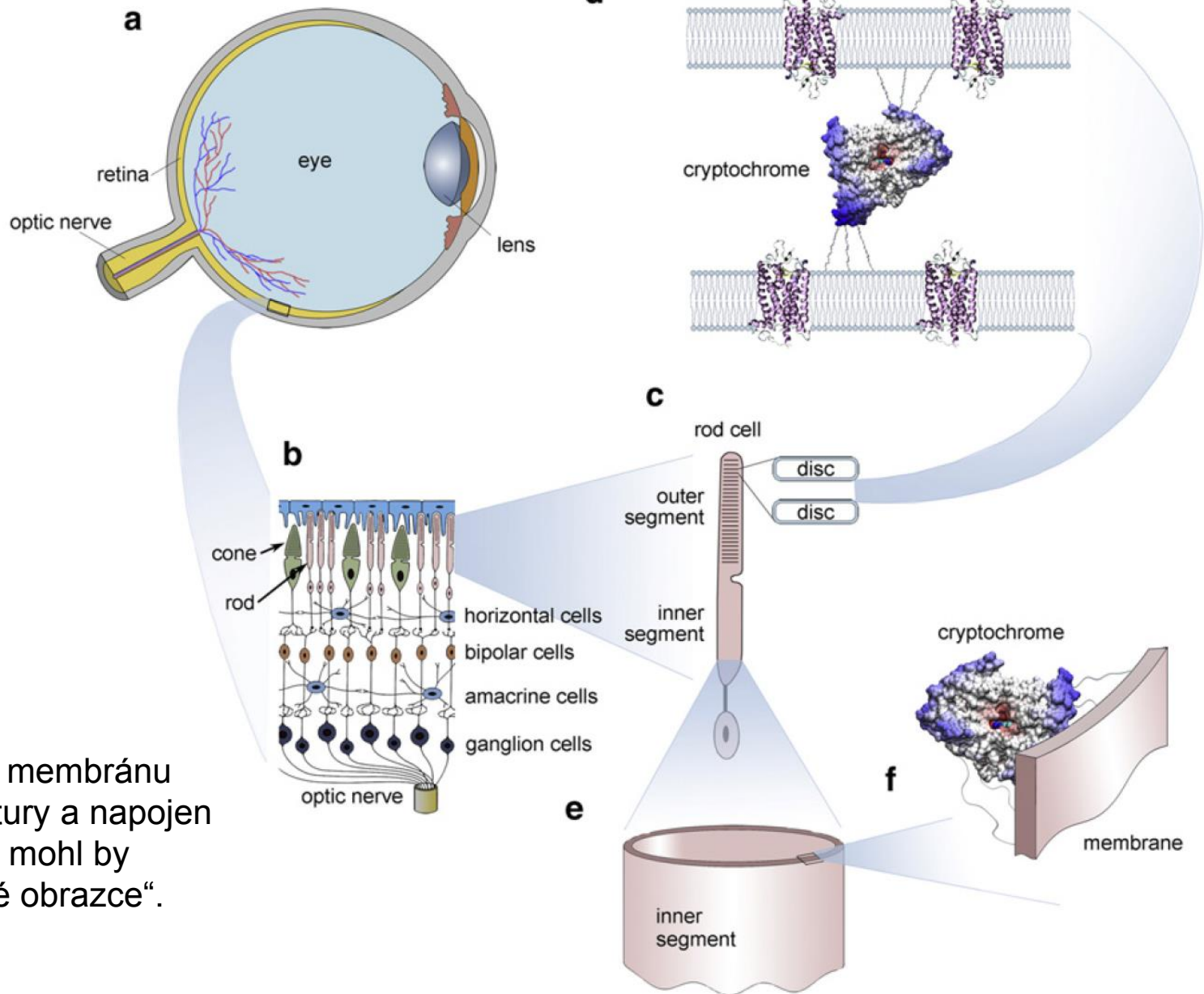

Je-li Cry fixován na membránu polokruhové struktury a napojen na zrakovou dráhu, mohl by vytvořit „magnetické obrazce“.

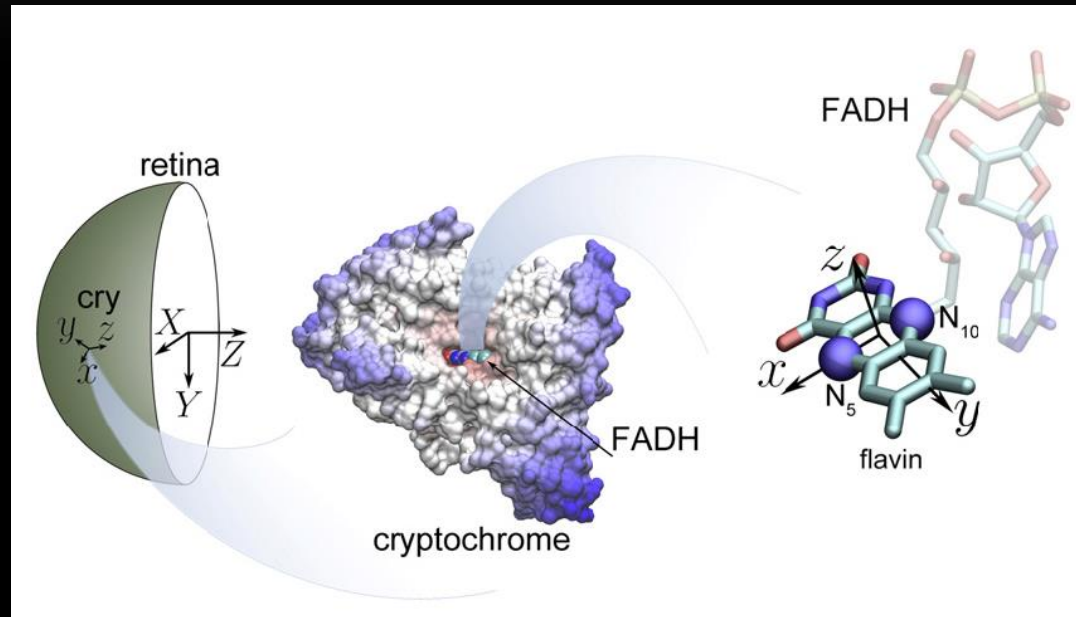

Reakce je směrově specifická a některé receptory v polokruhové struktuře (nejspíše sítnici) budou ovlivněny více než ostatní.

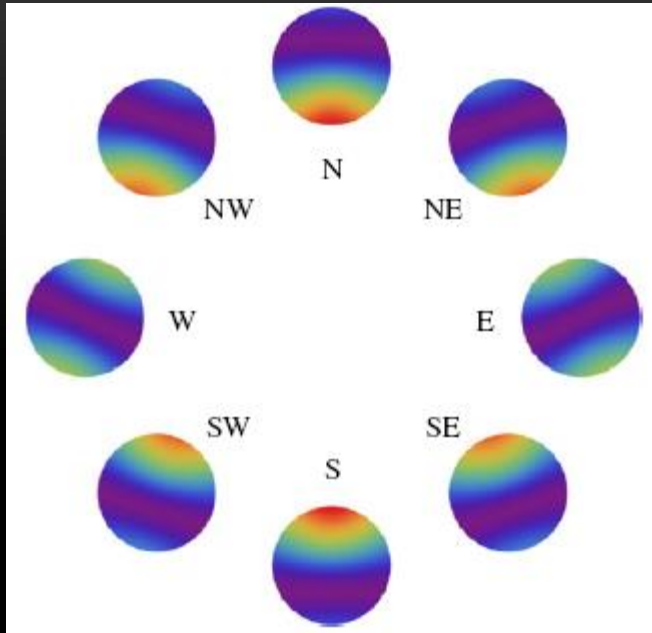

Je-li Cry fixován na membránu polokruhové struktury a napojen na zřakovou dráhu, mohl by vytvořit „magnetické obrazce“.

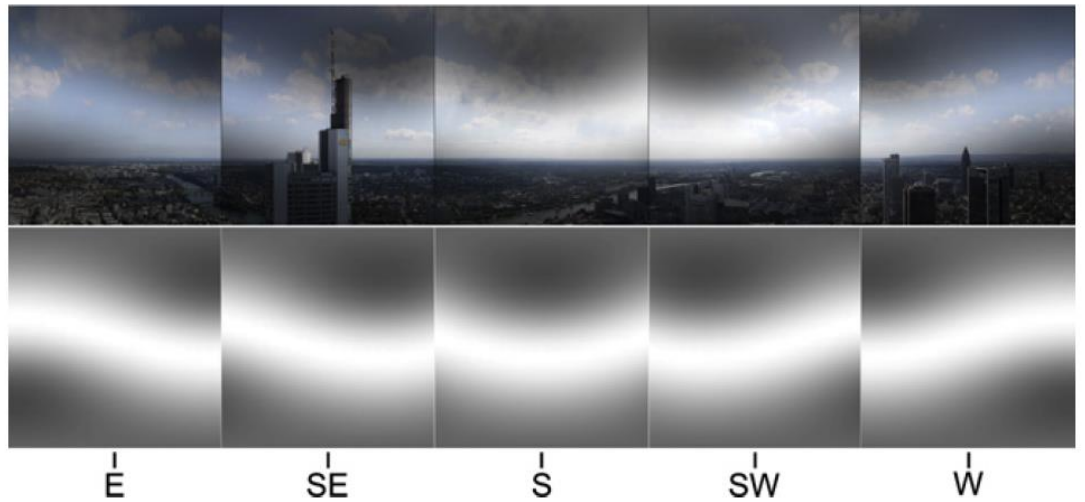
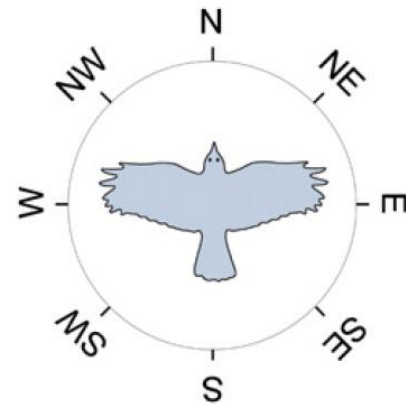
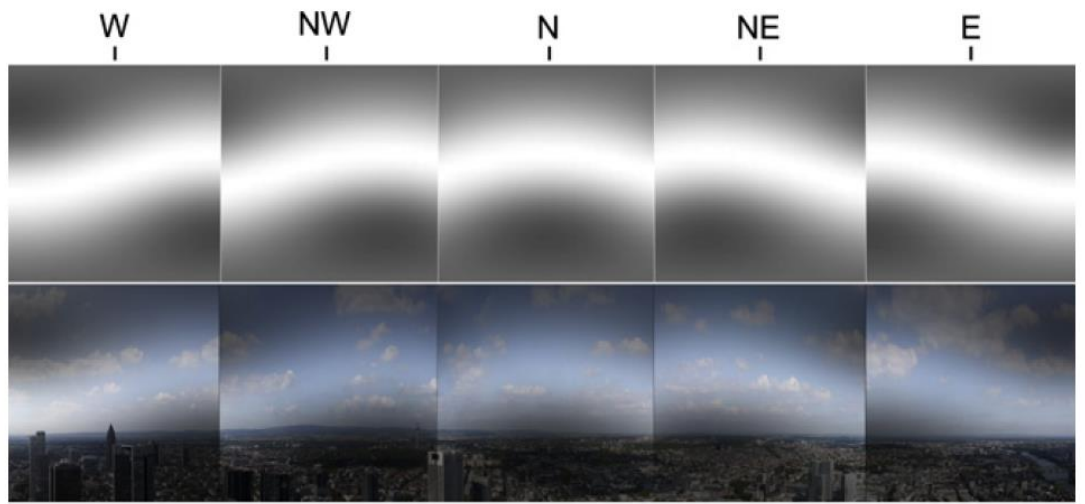

Jaké jsou možné mechanismy magnetorecepce?
Co víte o kryptochromech?

Možná otázka

ELEKTRORECEPCE

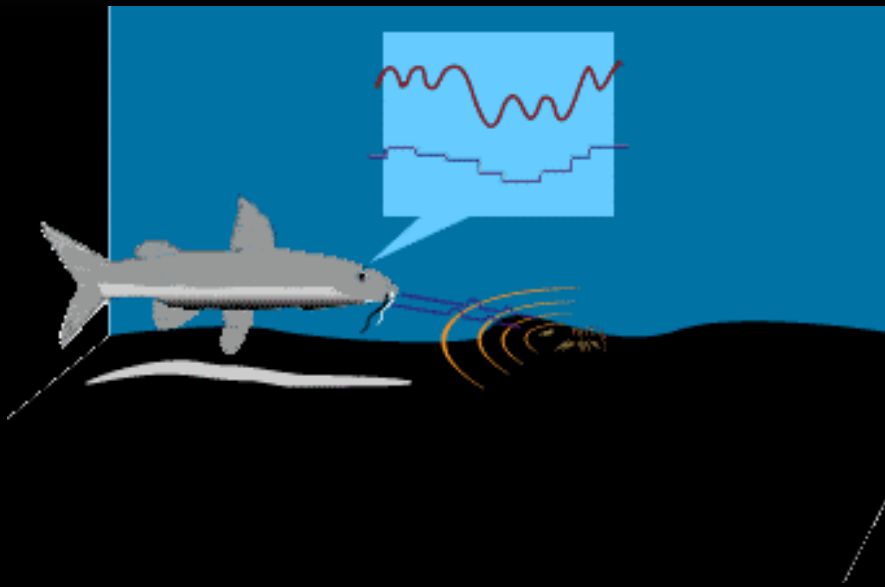

Lorenzini ampule

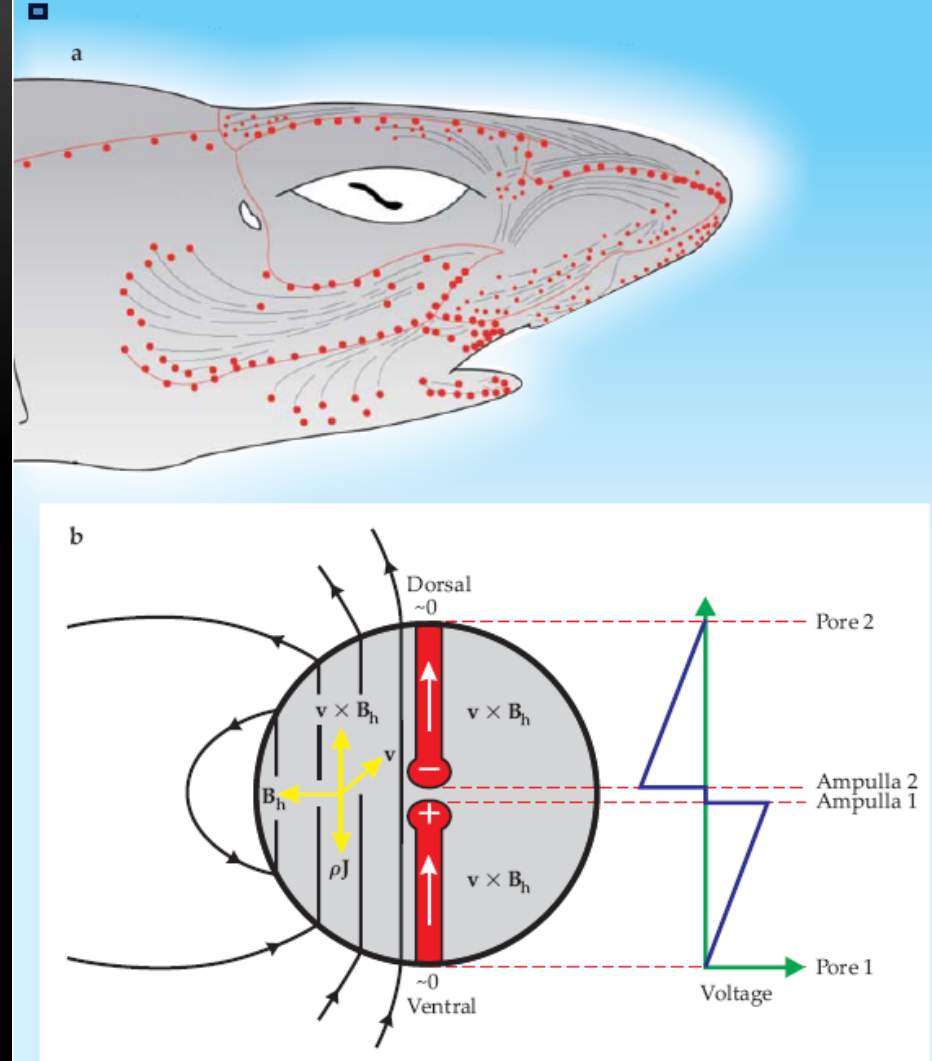
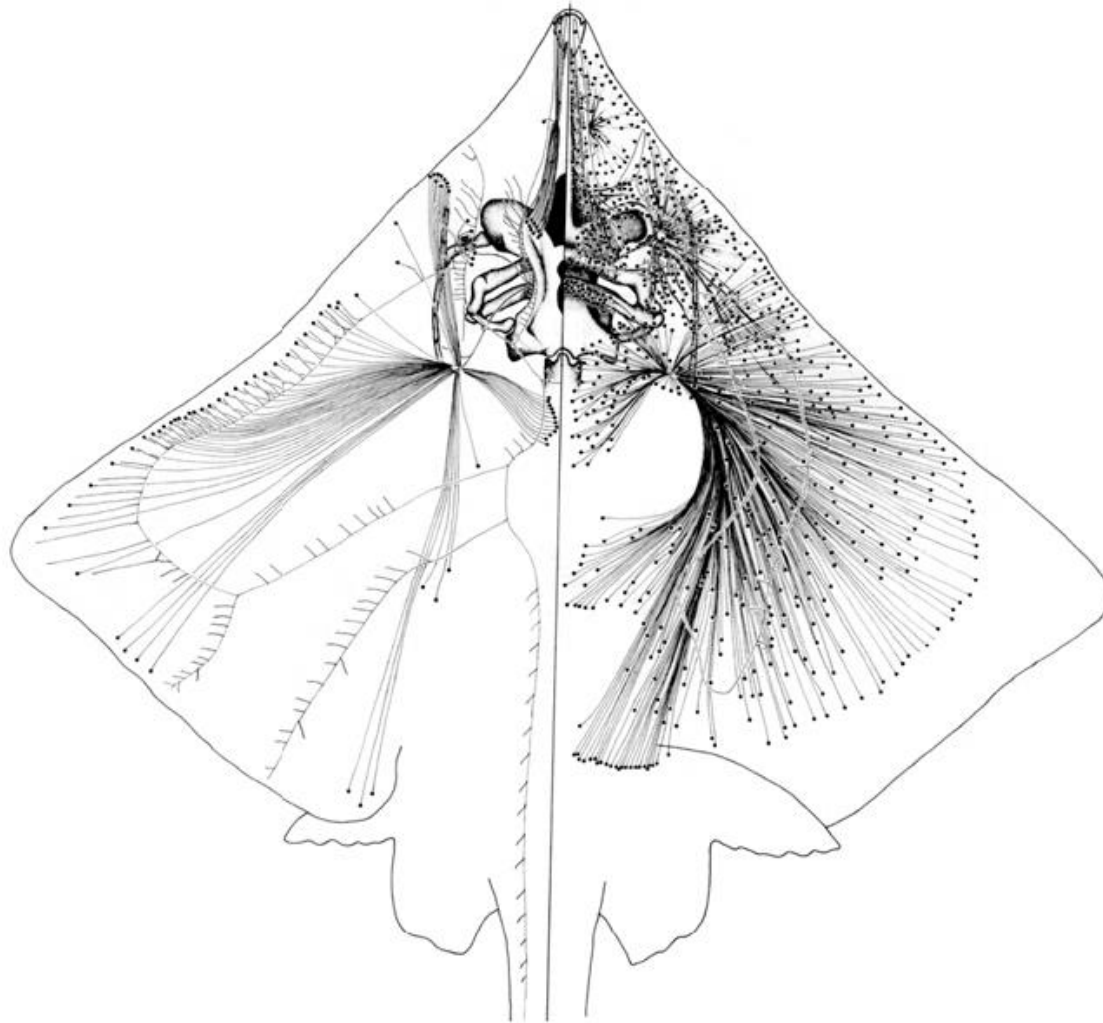
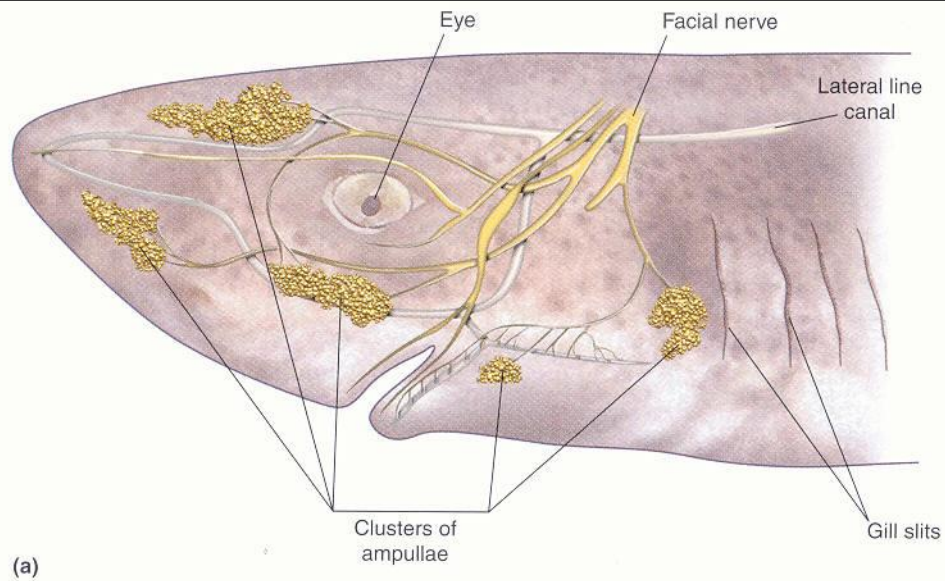

Figure 1. Inductive magnetoreception. (a) Side view of a shark's head, showing the ampullae of Lorenzini electroreceptors (red dots) and jelly-filled conductive canals (gray lines). The red lines are so-called lateral lines, used to detect vibrations in the surrounding water. (Image courtesy of Chris Huh.) (b) Schematic showing two ampullae with their canals. As the shark swims east and into the page with a velocity v , its movement across the horizontal component of Earth's field, B_h , causes a vertical electromotive force of magnitude vB_h . Because the shark's body and especially its skin are highly resistive, the voltage drop due to the current density ρJ results in no potential difference between the dorsal and ventral surfaces of the animal. The high conductivity of the canals, however, results in a large voltage drop across the ampullae. The thick black lines illustrate the electric field surrounding and permeating the shark. (Adapted from A. Kalmijn, *IEEE Trans. Magn.* **17**, 1113, 1981.)



1. Rozmístění Lorenziniho ampul na těle rejnoka druhu *Raja laevis*. V levé polovině obrázku je znázorněna dorzální, v pravé polovině pak ventrální strana těla. Vpravo nahoře je detail izolované ampuly; dobře jsou viditelné receptorové buňky na dně ampuly a senzorní nerv. Podle: Raschi, J. Morphol. 189, 225–247, 1986.



(a)

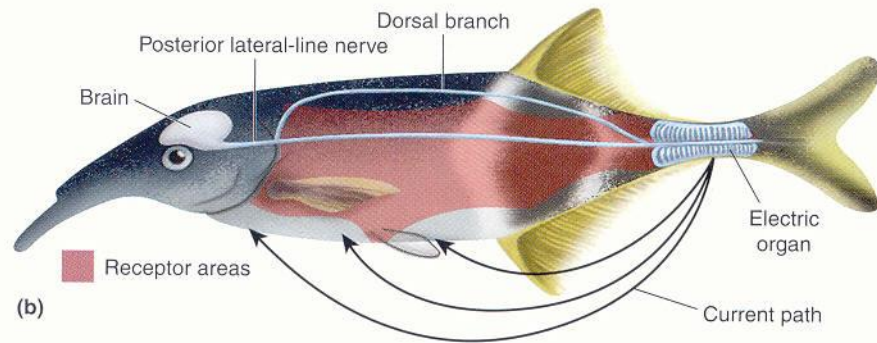

(b)

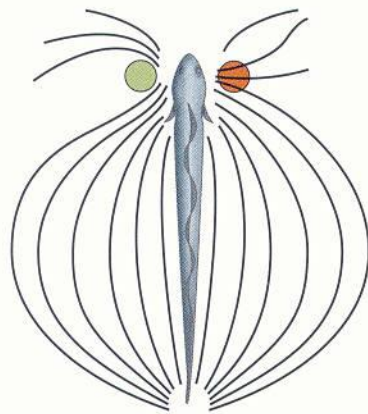

(c)

command center is
 Gap junctions assure
 maximizing signal in
 pling of the medulla
 tor that determines
 of electrocytes capal

A few species, s
 produce discharges
 bodies, whereas in
 range to millivolts to
 or kill prey, whereas
 for electrolocation a

■ Some animals

Co je podstatou? Kanály řízené (vrátkované) napětím

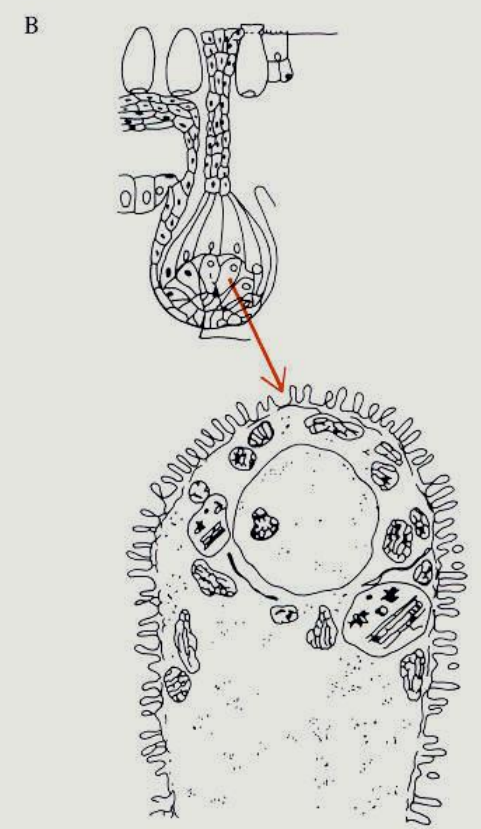
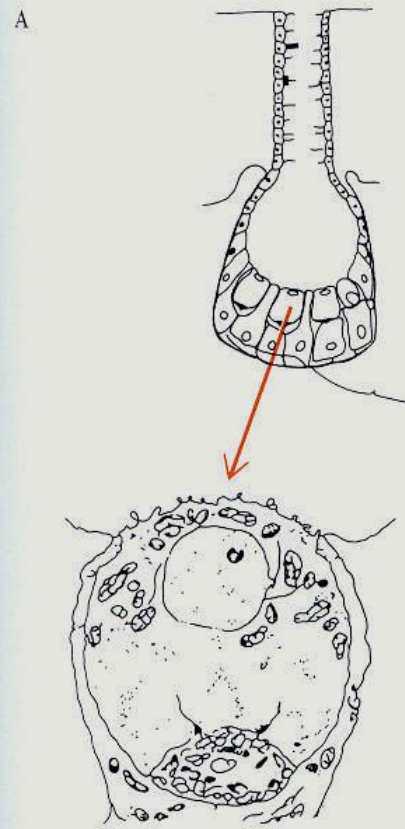

Tonic ampullary electroreceptor

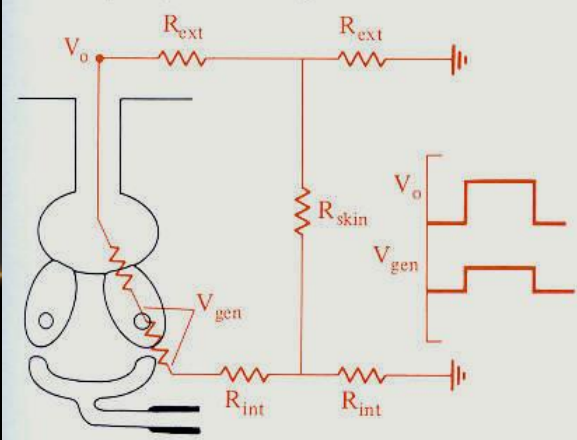

Phasic tuberous electroreceptor

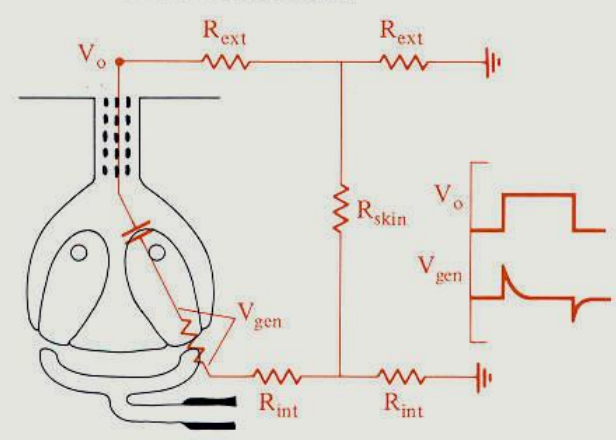

- Pasivní – detekce napětí vznikající svalovou a nervovou činností

- Aktivní – podobá se echolokaci

- Navigace

- Detekce kořisti

- Komunikace



v kalných vodách nebo v noci

Lorenziniho ampule – změna potenciálu otevírá Ca^{2+} kanály a stimuluje eflux mediátoru

Možná otázka

CÍTĚNÍ PŘES TRP KANÁLY

TRP – TRANSIENT RECEPTOR POTENTIAL

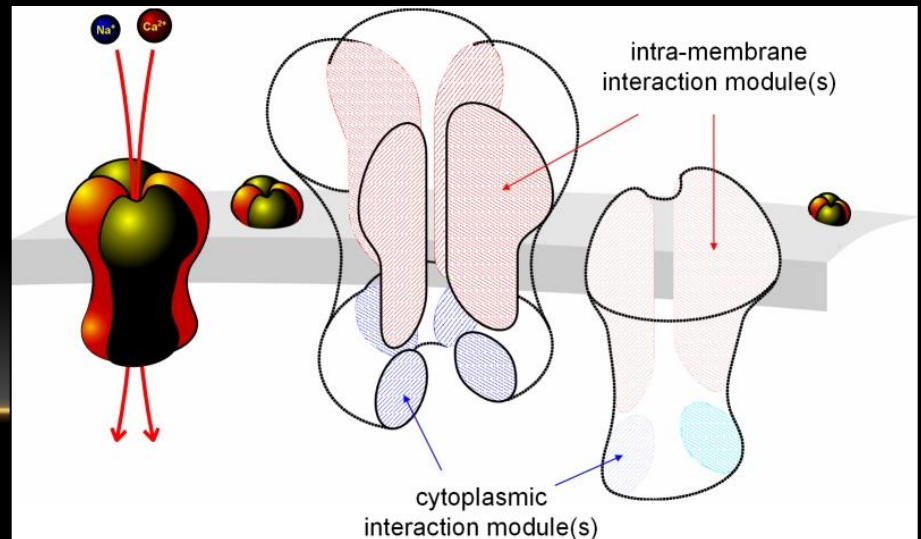
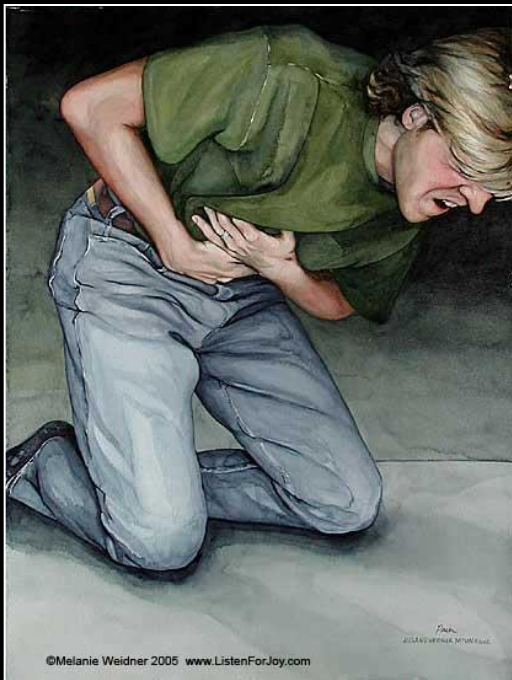

Objeveny v oku octomilky 1969

Univerzální buněčné sensory změn v okolním prostředí – slouží i organismům
Evoluční specializace na zrak, čich, chuť, sluch, dotek, osmolalitu, teplotu, bolest.

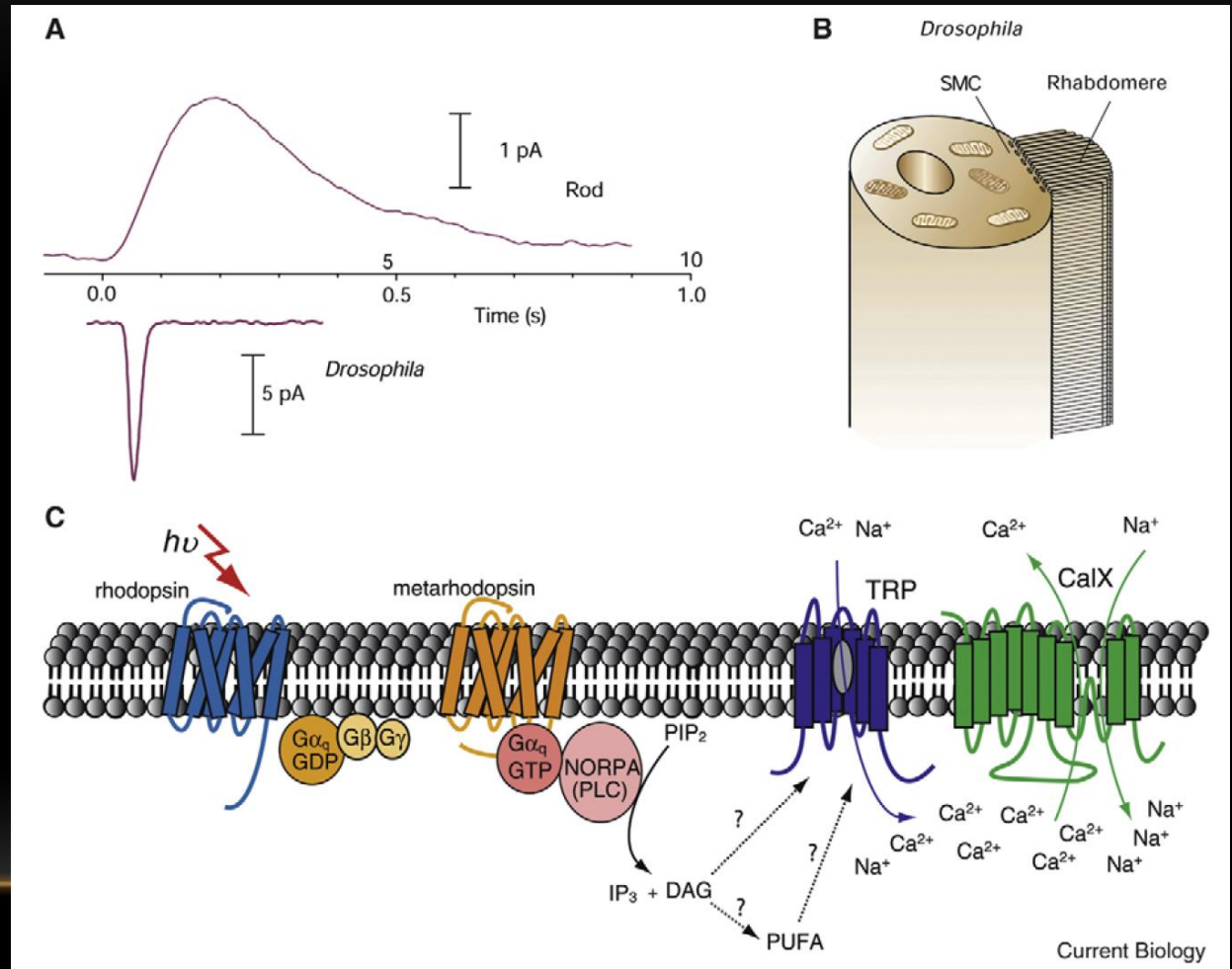

TRP superrodina je specifická třída kanálů, které se otevírají v odpověď na celou škálu chemických a fyzikálních stimulů. Díky této škále vrátkování, TRP kanály slouží jako univerzální senzory, které dovolují buňkám a celým organismům detekovat změny v jejich prostředí.

Během evolučního vývoje došlo k pozoruhodné specializaci těchto bílkovinných komplexů tak, že mohou měnit svou konformaci vlivem různých chemických i fyzikálních podnětů: mohou hrát roli při zraku, čichu, chuti (sladka, hořka a umami), sluchu, doteku, osmolality, pH, teploty, bolesti od kvasinky a háďátka přes Drosophilu k člověku. Tedy téměř všech prozkoumaných modalit.

Některé TRP kanály jsou přímo receptory, zatímco jiné jsou efekторы výše stojících s G-proteinem spřažených receptorů. Některé TRP kanály fungují jako buněčná čidla, která převádějí změny okolního prostředí na produkci druhých poslů uvnitř buněk, a to především vápníku, čímž dochází k aktivaci nebo modulaci činnosti dalších receptorů.

Různé teplotní nastavení

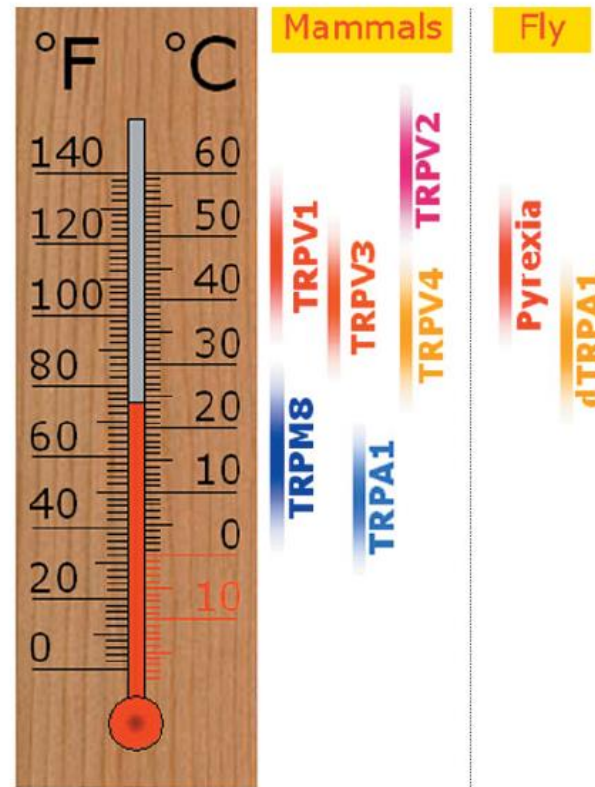

Figure 2 Activation range of human and *Drosophila* thermoTRPs. Indicative temperature range for activation of mammalian and *Drosophila* thermoTRPs in heterologous expression systems. Note that TRPM8 and TRPA1 are activated upon cooling, whereas all other indicated channels are heat activated.

Molekulární identifikace teplotně aktivovaného iontového kanálu TRPV1, který se uplatňuje v přenosu bolestivých podnětů na primárních nociceptivních neuronech, vedla k prudkému zvýšení zájmu fyziologů o další iontové kanály této skupiny a díky rozsáhlým genomickým projektům ukázala existenci obecných molekulárních principů sensorické transdukce.

U člověka bylo dosud identifikováno 27 genů pro TRP receptory a jejich fyziologická úloha byla prokázána v souvislosti s některými onemocněními, jako jsou poruchy metabolismu hořčíku (hypomagnezémie), polycystická onemocnění ledvin, nebo mukolipidózy (poruchy odbourávání glykoproteinů a jejich hromadění ve tkáních).

Některé podtypy TRP receptorů se nacházejí v nedráždivých buňkách, jako jsou např. keratinocyty, ledvinný epitel a prostata.

Thus, snakes detect infrared signals through a mechanism involving radiant heating of the pit organ, rather than photochemical transduction. These findings illustrate the broad evolutionary tuning of transient receptor potential (TRP) channels as thermosensors in the vertebrate nervous system.

Nature doi:10.1038/nature08943

Jak testovat termosensitivu?

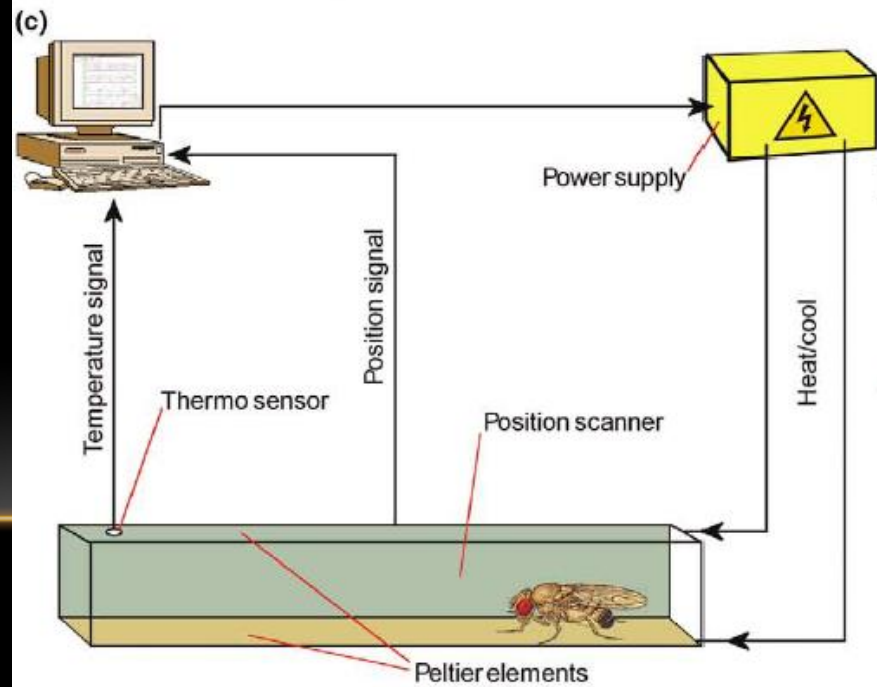

Mechanosensitivita TRP

Sluch

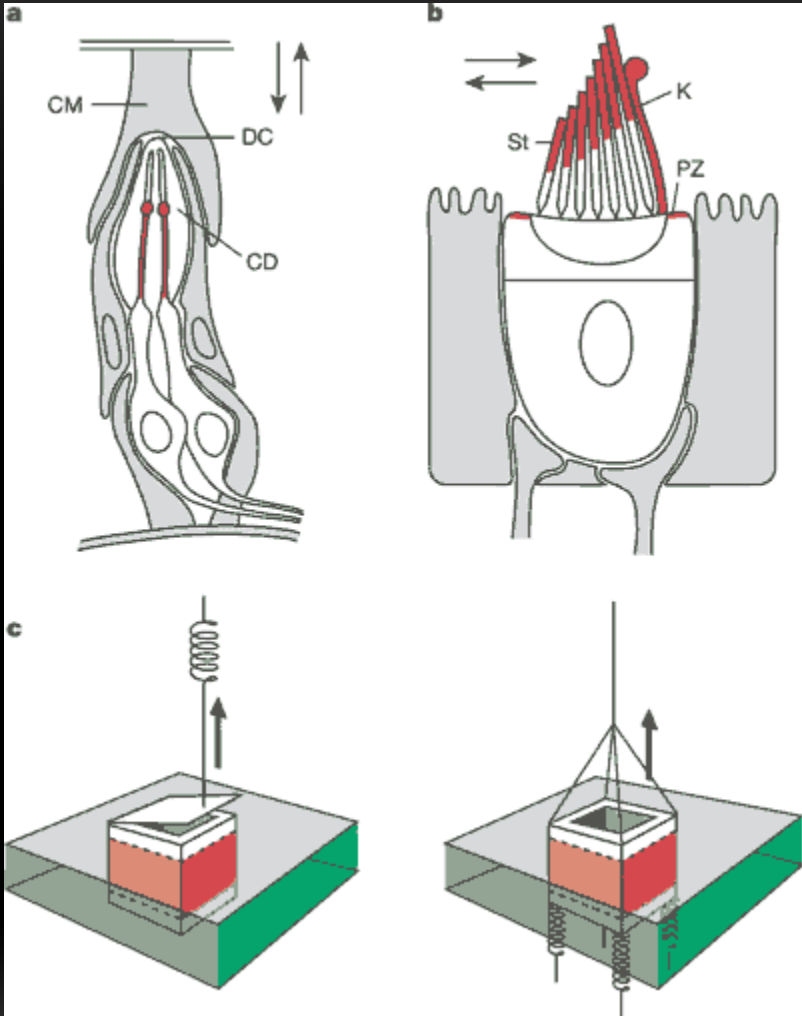

TRP kanály: sensory gasotransmitterových signálů

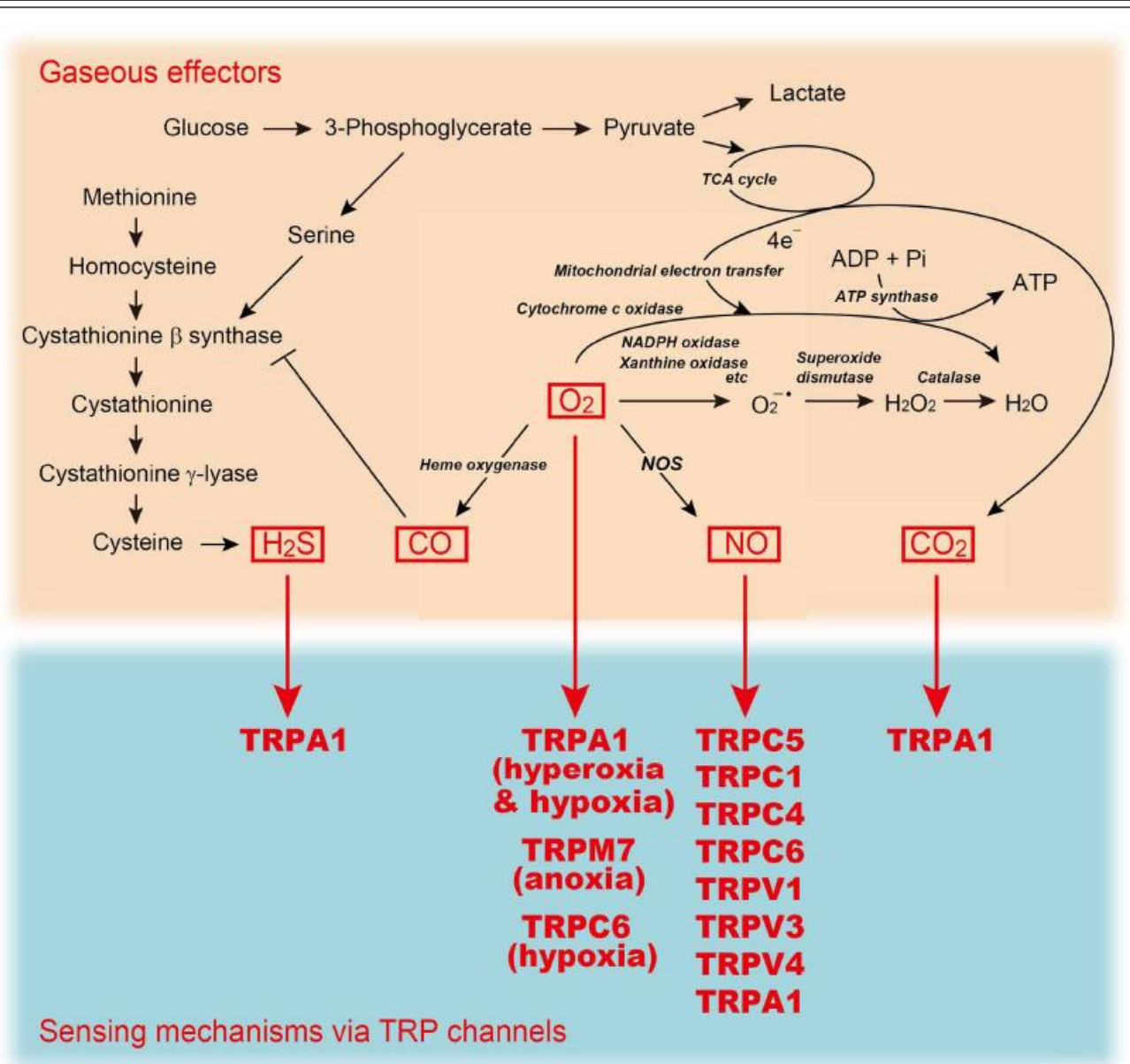

FIGURE 2 | A sensing mechanism for gaseous molecules linked to metabolic pathways. TRP channels mediate sensing mechanism for H₂S, O₂ (anoxia, hypoxia, or hyperoxia), NO, and CO₂.

NO
zprostředkovaná
dráha vedoucí k
relaxaci hladké
svaloviny endotelu

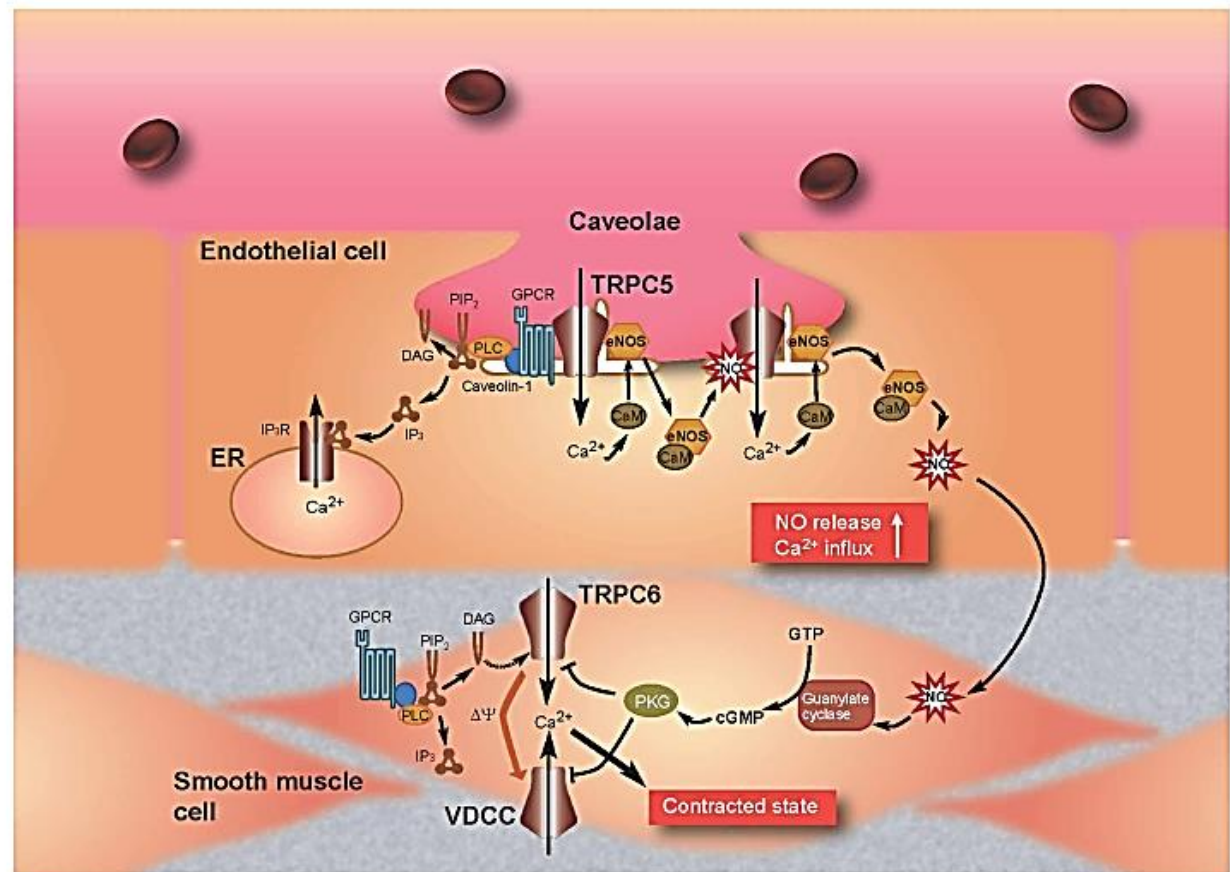
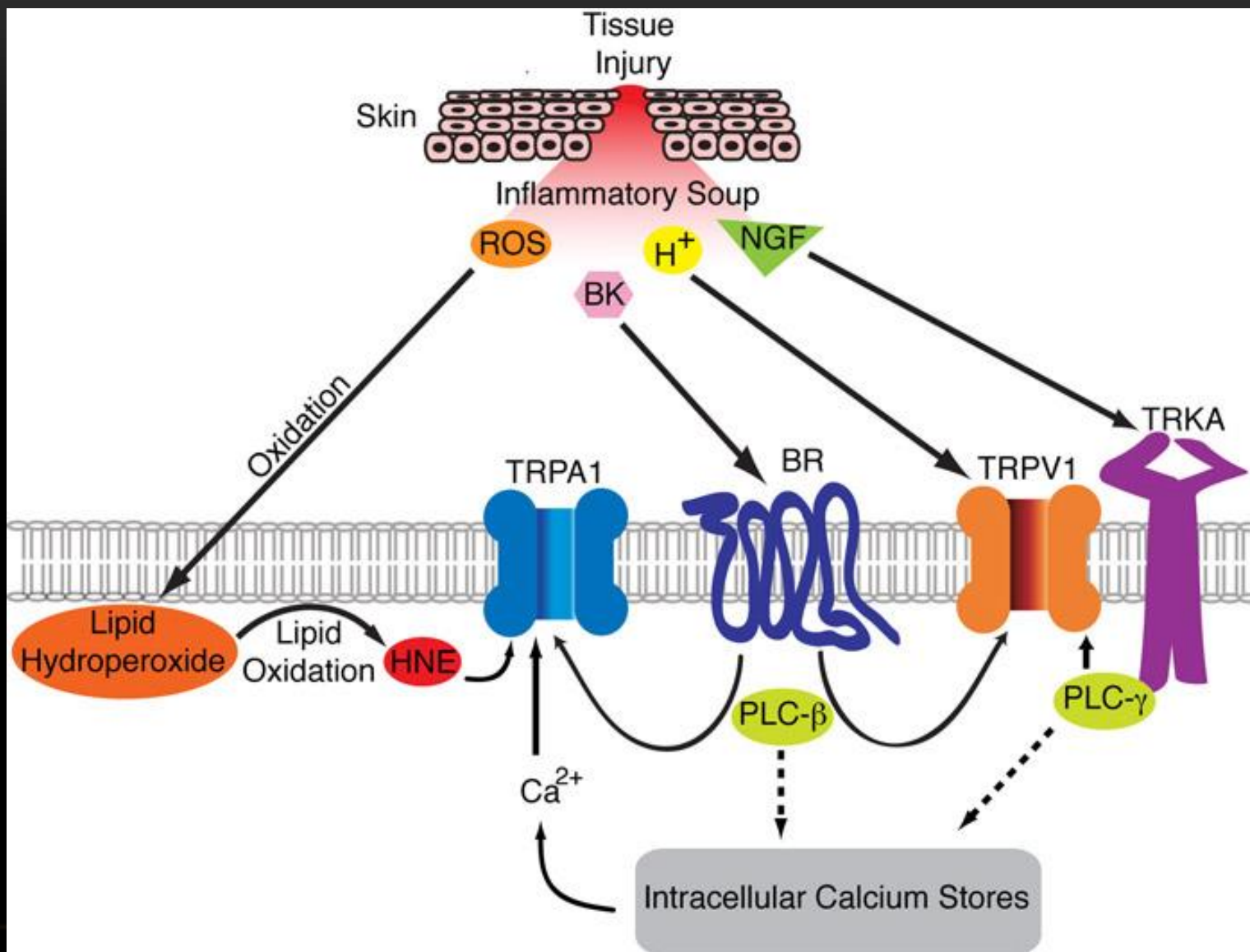

FIGURE 4 | Model for TRPC5-mediated feedback of Ca^{2+} and NO signaling in endothelial cells and attenuation of Ca^{2+} entry through TRPC6 by NO in smooth muscle cells. Stimulation of G protein-coupled receptors (GPCRs) (such as the ATP-activated P2Y receptor) induces Ca^{2+} influx and activation of eNOS as a consequence of binding of Ca^{2+} -CaM and release of eNOS from caveolin-1. TRPC5 undergoes eNOS-dependent S-nitrosylation after GPCR stimulation, resulting in amplified Ca^{2+} entry and secondary activation of eNOS to amplify production of NO. NO diffuses out of endothelial cells into adjacent smooth muscle cells and stimulates the

guanylate cyclase, which leads to the activation of PKG in smooth muscle cells. In the most prevailing hypothesis, the magnitude of continuous Ca^{2+} influx through VDCC, which critically determines the contractile status of vascular smooth muscle cells, decreases and increases by membrane hyperpolarization and depolarization, respectively. TRPC6 likely functions as a depolarization ($\Delta\psi$)-inducing channel or a direct Ca^{2+} -entry pathway, activated in response to receptor stimulation. The NO/cGMP/PKG pathway suppresses TRPC6 and VDCC activity to induce relaxation of smooth muscle.

TRP v recepci lokálního buněčného prostředí – buněčná signalizace



TRPA1 and TRPV1 function as polymodal signal integrators capable of detecting chemically diverse products of cell and tissue injury. In doing so, these channels promote pain hypersensitivity by depolarizing the primary afferent nerve fiber and/or lowering thermal or mechanical activation threshold.

TRP v recepci lokálního buněčného prostředí – buněčná signalizace

Vazomotorika, transport tekutin přes membrány, hormony, sekrece inzulínu. Neurodegenerace přes oxidativní stres, kardiovaskulární nemoci, sensorické deficity, abnormální reakce na bolest, gastrointestinální, renální, neurodegenerativní poruchy, astma, onkologické a i psychiatrické poruchy.

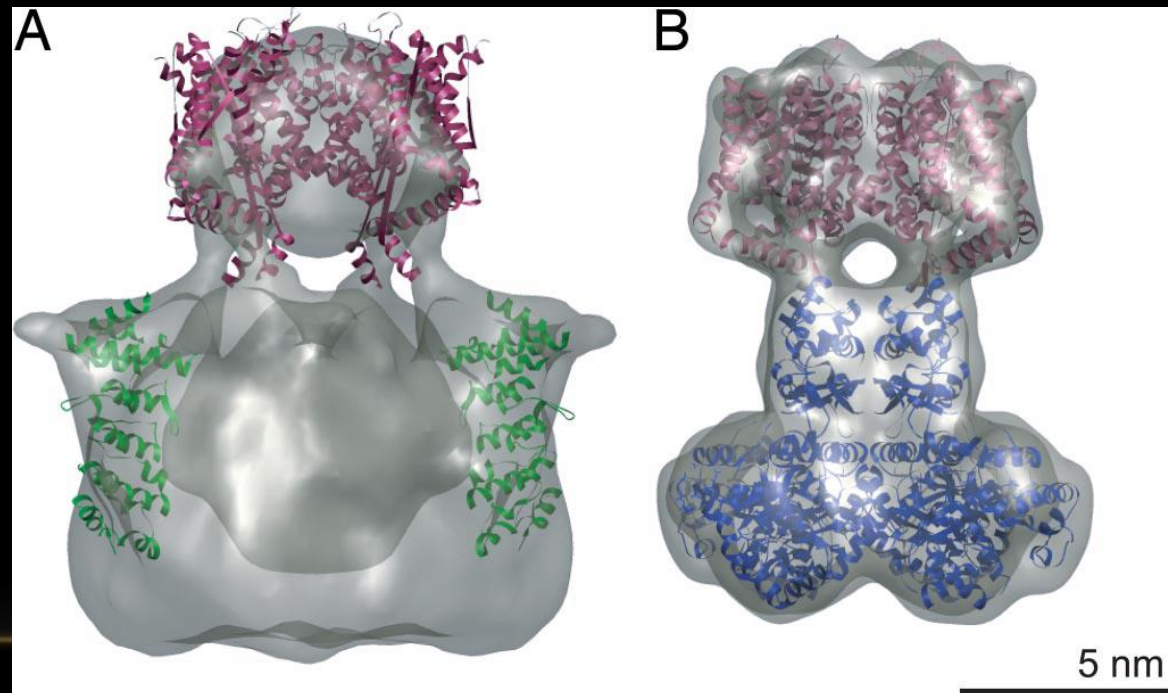

Studium TRP kanálů je zajímavé nejen pro jejich univerzální roli ve smyslové transdukci, ale i směřuje k hlubšímu porozumění mechanismů, které se uplatňují při vzniku některých onemocnění nervového systému a k cílenému hledání prostředků pro jejich léčbu. Jejich studiem se blížíme pochopení Ca citlivých mechanismů Ca regulace neexcitabilních buněk jako je aktivace T buněk, řízení apoptózy, proliferace, sekrece a buněčné migrace.

Charakterizujte funkci a význam TRP kanálů.

Možná otázka

- Závěrem: Buňky konzervativně využívají již vyzkoušených mechanismů k předávání signálů. Schopnosti buněk vidět, slyšet, čichat se svými mechanismy neliší od schopností regulovat vývoj, zrání, diferenciaci, transport, metabolismus a homeostázu. Studiem smyslových schopností poznáváme obecná pravidla molekulární komunikace.

- Úloha bezobratlých jako modelu
- Úloha neuroetologie

