

# S4001: International Performance Course

CEITEC, 2020

## ACADEMIC WRITING INTRODUCTION

Task 1: *What is academic writing?*

<b><u>Who?</u></b> <i>Who is writing?</i> <i>Who is the audience?</i>	<b><u>What?</u></b> <i>What is the writing about?</i>	<b><u>Why?</u></b> <i>Why is the writing done?</i>

Task 2: **ACADEMIC AUDIENCE**

*Write as many types of texts students/academics produce for different audiences as possible. Discuss them with the rest of the group.*

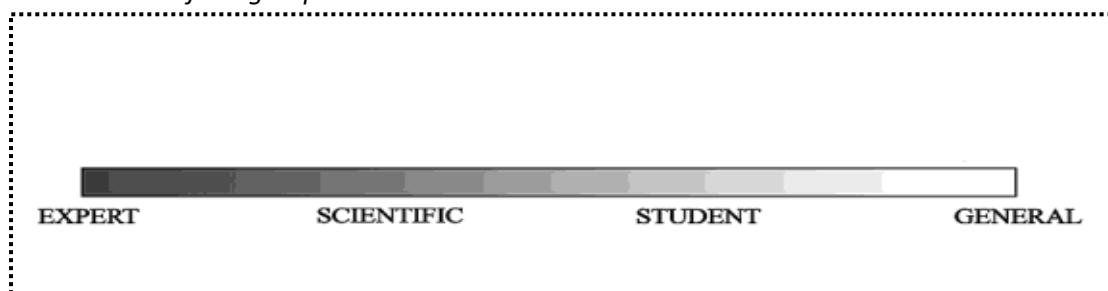

(Adapted from Robinson, M., Stoller, F. (2008): Write like a Chemist, OUP, Oxford, p.10)

## Complexity

Written language is usually more complex than spoken language. It has more complex and varied vocabulary and grammar; it uses more nominal phrases and it tends to be longer than spoken language. We will take a look at some aspects of the academic writing style.

## STYLE

**Task 1:** *Look at these four different styles of saying the same thing and identify the academic style.*

a) It rained cats and dogs yesterday, didn't it?

b) What a downpour last night!

c) The UK Meteorology Office monitored a heavy rainfall with the rate of precipitation reading 46 millimetres per hour on 24th March 2011 in North Cumbria.

d) She was standing there in the storm waiting for deafening thunder to come, feeling the water cooling the air and thinking of how heavy the drops of water must be so that they could fall down from the dark clouds and make her feel refreshed and so light that she could fly, and make her full of energy, make her appreciate the eternal life it delivers, when finally she realised this precipitation was indeed a friend, her only true friend.

## CONCISE WRITING

Concise writing presents information that is important to the reader. There are no unnecessary words, sentences or paragraphs. Redundant expressions and structures are eliminated or replaced wordy with more concise words or phrases that have the same meaning.

**Task:** *Rewrite the following pieces of texts to make them more concise.*

### **Example:**

*Chromatography is an experimental technique used by chemists as a means to help them separate different compounds in experimental samples using the affinity of the compound for the mobile phase as well as the affinity of the compound for the stationary phase.*

a) As shown in a paper by Conderoy et al (2008), there is an increasing amount of evidence that suggests an association between cancer and the cyclooxygenase (COX) enzyme (5); hence, the COX-expressing cell line HT-29 was studied in this present work.

b) In order to determine the rate of the reaction, the temperature was increased.

### **FORMALITY**

Academic writing is usually formal, which means, in general, that we should avoid colloquialisms and informal words and structures.

**Task 1:** *Read the sentence triplet below and discuss which of the examples are suitable for an academic text from the perspective of formality. How many levels of formality do you use in your writing? Why? What are their features?*

a) Essential measures should be undertaken at the earliest opportunity.

b) You should do whatever you have to as soon as you can.

c) One should undertake any necessary measures at the earliest opportunity.

**Task 2:** *Identify informal expressions in the following sentences and replace them with a more formal (academic) equivalent.*

a) Several countries have actually established standards for PCBs in dietary products such as fish, meats, and eggs.

b) This kind of network represents an interesting environment.

c) In general, rainfall is a bit acidic because of the presence of dissolved carbonic acid.

(Adapted from: UEFAP: <http://www.uefap.com/writing/feature/intro.htm>)

**Task 3:** *Match the informal expressions 1-10 with their academic a-j synonyms.*

- |               |                 |
|---------------|-----------------|
| 1. do         | a. frequently   |
| 2. so         | b. considerably |
| 3. often      | c. however      |
| 4. find       | d. conduct      |
| 5. very       | e. discover     |
| 6. get rid of | f. consequently |
| 7. but        | g. eliminate    |

(Adapted from: Štěpánek, deHaaff, 2011:21)

**Task 4:** *Re-write this sentence into a more formal style.*

I don't think you can trust his results. Just look at the studies he did before. The arguments were complete rubbish.

### **DE-PERSONALISATION**

Written language is usually objective rather than personal, which means that the information and arguments are emphasised not the authors.

**Task:** *Rewrite the sentences below so that they are depersonalised.*

a) Numerous studies have shown that seagrasses are very important to coastal productivity (Stohl, 1987, Rodel, 2004). We decided to examine whether this was also the case in the Bay of Biscay.

b) We wanted to understand how penicillin affects growth of bacteria.

*On self-mention in academic articles: Frequency of self-mention forms per discipline (Ø per 10,000 words).*

<b>Discipline</b>	<b>Total</b>	<b>Citation</b>	<b>I</b>	<b>Me</b>	<b>My</b>	<b>We</b>	<b>Us</b>	<b>Our</b>	<b>Other</b>
<b>Physics</b>	64,6	8,7	0,0	0,1	0,0	39,3	0,6	14,4	1,4
<b>Marketing</b>	61,3	6,9	1,6	0,0	0,7	31,0	1,1	18,9	0,6
<b>Biology</b>	56,2	22,6	0,0	0,1	0,1	24,0	1,1	7,2	0,7
<b>Philosophy</b>	52,7	3,1	35,6	2,5	7,7	1,4	0,2	0,6	0,0
<b>Electronic eng.</b>	44,4	10,7	0,0	0,0	0,0	23,3	0,4	8,6	0,5
<b>Mechanical eng.</b>	17,8	9,6	0,0	0,0	0,0	5,5	0,0	1,4	0,4
<b>Overall</b>	50,5	8,3	11,2	0,8	2,4	17,8	0,8	8,3	1,1

Source: K. Hyland/English for Specific Purposes 20 (2001) 207-226

## ACTIVE AND PASSIVE

*How do you use active and passive voices in academic writing?*

*Percentages of voice per section in the processes of three types of sciences in 21 research articles.*

	Introduction		Method		Results		Discussion	
	A	P	A	P	A	P	A	P
<b>Physical sciences</b>	63,0	37,0	26,0	74,0	72,0	28,0	71,0	29,0
<b>Biological sciences</b>	74,0	26,0	38,0	61,0	68,0	32,0	79,0	21,0
<b>Social sciences</b>	84,0	16,0	46,0	54,0	77,0	23,0	85,0	15,0

A=active, P=passive  
227-247)

Source: I.A.Martinez/English for Specific Purposes 20 (2001)

**NOTE:** To read more on passive: Lilita Rodman: The passive in technical and scientific writing;  
<http://www.jaconlinejournal.com/archives/vol2/rodman-passive.pdf>

**Task:** *Change the verbs in bold into the passive and change the sentences correspondingly.*

a) We **should reject** this conclusion for two reasons.

This conclusion .....

b) We **would never have published** this book without additional financial support from the Nansen Institute.

This book .....

c) A new satellite, which we **will launch** next month, **will detect** global pollution.

Global pollution .....

d) To preserve originality of thinking, we **have kept** editing of all chapters to a minimum.

To preserve originality of thinking, editing .....

e) Experts **presented** and **discussed** a total of ten innovative papers during the two-day workshop sessions.

A total .....

f) We **understand** the mechanics of isolating vibration well and we **have also determined** the necessary physical properties of the isolators.

The mechanics of isolating vibration .....  
.....  
.....

## NOMINALISATION (NOUN FORMS)

Academic writing uses often more noun structures than verb structures. The noun forms are useful in condensing texts and in focusing on conditions and results rather than actions.

**NOTE:** *Too much nominalisation can make academic writing very dense, unnecessarily complex and tedious to read, therefore, writers need to strike a balance between nominalised structures and verb-based phrases.*

**Task 1:** *What is the difference between the following sentences (ignore the grammar)?*

- a) The rapidly declining economy was causing concern among politicians.
- b) The economy was declining rapidly and that was causing concern among politicians.

**Task 2:** *Change the following verbs to nouns.*

- |             |               |           |
|-------------|---------------|-----------|
| a) increase | d) categorise | g) injure |
| b) occur    | e) exclude    | h) define |
| c) develop  | f) assess     | i) assume |

**Task 3:** *Identify nominalised expressions in the sentences below.*

- a) Reading between the lines requires an interactive approach to texts.
- b) A heat treatment results in the reaction of the surface of Si particles to form SiO<sub>2</sub>. The decrease of a particle size is monitored by a blue shift of the absorption maximum as a function of heating time.
- c) The University appreciates the use of special software for plagiarism identification in assignments used by lecturers.

**Task 4:** *Rewrite the following sentences to make them more nominalised.*

- a) Birds fly and that is essential if they want to survive.
- b) We analysed the data from the experiment which revealed that there were different trends.
- c) When a body reaches an abnormally low temperature, the person has to be taken to hospital.

(Adapted from : Williams, (1994): p.84; Štěpánek,L., deHaaff,J. (2011), p.51)

## COHERENCE AND COHESION

Academic writing uses cohesive devices and signalling words to make the relationships in the text explicit. The goal is to make it clear to the reader how the various parts of the text are related.

**Task 1:** *Read the paragraph and fill in the gaps with cohesive devices listed below.*

**a) however   b) What   c) According to   d) because of   e) which   f) Yet**

(1) ..... Jaspersen, human language originated while humans were actually enjoying themselves (2) ..... is one of the more endearing speculations concerning the origins of language. It remains, (3) ....., a speculation. We simply do not know how language originated. (4) ..... we do know is that spoken language developed well before written language. (5) ....., when we uncover traces of human life on earth dating back a million years, we never find any direct evidence relating to the speech of our distant ancestors. Perhaps, (6) ..... this absence of direct physical evidence, there has been no shortage of speculation about the origins of human speech.

**Task 2:** *Read the two paragraphs below and decide which of them has a better overall plan. Support your opinion with evidence.*

**a)** The ancient Egyptians were masters of preserving dead people's bodies by making mummies of them. Mummies several thousand years old have been discovered nearly intact. The skin, hair, teeth, finger- and toenails, and facial features of the mummies were evident. It is possible to diagnose the diseases they suffered in life such as smallpox, arthritis, and nutritional deficiencies. The process was remarkably effective. Sometimes apparent were the fatal afflictions of the dead people: a middle-aged king died from a blow on the head, and polio killed a child king. Mummification consisted of removing the internal organs, applying natural preservatives inside and out, and then wrapping the body in layers of bandages.

**b)** The ancient Egyptians were masters of preserving dead people's bodies by making mummies of them. The process of mummification consisted of removing the internal organs, applying natural preservatives inside and out, and then wrapping the body in layers of bandages. It was a remarkably effective practice. Indeed, mummies several thousand years old have been discovered nearly intact. Their skin, hair, teeth, fingers and toenails, and facial features of the mummies are still evident. Their diseases in life, such as smallpox, arthritis, and nutritional deficiencies, are still diagnosable. Even their fatal afflictions are still apparent: a middle-aged king died from a blow on the head: a child king died from polio.

## HEDGING / LANGUAGE OF CAUTION / TENTATIVE LANGUAGE

Our previous sections might give the impression that academic writing is factual, conveying precise, accurate and objective facts and information. “However, it is now recognised that an important feature of academic writing is the concept of cautious language, often called “hedging”. In other words, it is necessary to make decisions about your stance on a particular subject, or the strength of the claims you are making.”

### *Functional classification of hedges*

<b>Hedge Class</b>	<b>Function</b>
<b>Shields</b> Devices that take responsibility for the claim made away from the author. They function as a tool protecting the author from any criticism. The writer aims at not being on record with regard to the propositions expressed in the text.	<b>Responsibility shifting</b> Devices which suggest that in case there is another interpretation of the propositions made, the criticism should be aimed at somebody else. The person or people accountable for the claim are known or can be found. <i>e.g. ...([1], [2], [3],),..., ...it is shown in [3]..., Romanowska found..., ...we refer reader to [3, 4]..., ...see [10]...</i>
	<b>Speaking facts</b> The author indicates lack of other interpretation. The writer shields his/her claims through stating “the commonly accepted” view. <i>e.g. Definition 1..., A map is..., ...is defined to be..., ...space is said to be...</i>
<b>Mitigators</b> The author admits his/her responsibility for the claims made. The writer takes stance while using mitigators, but decides to weaken his/her propositions for various reasons.	<b>Approximation</b> Referring vaguely to the quality or quantity of something. <i>e.g. ...some..., ...more..., Several, ...similar...</i>
	<b>Possibility</b> Referring to things that may happen or be the case. <i>e.g. ...may..., ...can..., ...possible...</i>
	<b>Understatement</b> Devices used to downgrade the claims and express modesty generally expected from authors of scientific articles. By using these devices, they lessen the importance and the validity of their claims. <i>e.g. ...notions..., ...concept...</i>
	<b>Admitting incompleteness</b> The author expresses that some facts might have been omitted or that there might be other possibilities that have not been covered by the research article scope. <i>e.g. ...briefly..., ...however,...</i>



*Linguistic classification of hedges*

<b>Introductory verbs</b>	e.g. seem, tend, look like, appear to be, think, believe, doubt, be sure, indicate, suggest
<b>Modal verbs</b>	e.g. would, may, might, could
<b>Adverbs of frequency</b>	e.g. often, sometimes, usually
<b>Modal adverbs/ adjectives</b>	e.g. probably, possibly / probable, possible
<b>Modal nouns</b>	e.g. assumption, possibility, probability
<b>“That” clauses</b>	e.g. It could be the case that.... It might be suggested that...
<b>“To”-clause + adjective</b>	e.g. It may be possible to obtain

This system prevents attacks on both server and client sides.



According to simulation studies, under some circumstances this system may reduce certain types of attacks on both server and client sides.



~~It could be concluded that some evidence seems to suggest that this system might, under some circumstances, have the tendency to reduce at least certain types of attacks on both server and client sides.~~

**Task:** *Examine the pairs of sentences below for hedging. In each pair, discuss the difference in meaning in the sentences with and without hedging.*

a<sup>1</sup>) This finding **proves** that the combination of sulforaphane, indole carbinol, and chlorophyll with Se did not provide additional protection against mammary tumors.

a<sup>2</sup>) This finding **suggests** that the combination of sulforaphane, indole carbinol, and chlorophyll with Se did not provide additional protection against mammary tumors.

-----  
b<sup>1</sup>) The fluorescence lifetime measurement of the diol/carbonate pair **will be complete** in two months.

b<sup>2</sup>) The fluorescence lifetime measurement of the diol/carbonate pair **is expected to be complete** in two months.  
-----

c<sup>1</sup>) **It is estimated** that in the next fifty years the world's population **might** again grow 40-50% and if we continuously **used** the amount of water that we are currently using the water supply **may** significantly diminish.

c<sup>2</sup>) In the next fifty years the world's population **will** again grow 40-50% and if we continuously **use** the amount of water that we are currently using the water supply **will** significantly diminish.

-----  
d<sup>1</sup>) We found that the pressure **increased** as the temperature **rose**, which **indicated** that temperature **played** a significant role in the process.

d<sup>2</sup>) We found that the pressure **increases** as the temperature **rises**, which **indicates** that temperature **plays** a significant role in the process.

### **ACCURACY AND PRECISION**

In academic writing, information, facts and figures are presented precisely. There is some difference between "accuracy" and "precision". Being "accurate" means using the right words to express exactly what you want to present and share, on the other hand, being "precise" giving exact factual information.

**Task 1:** *In the following construction, do the following adjectives have a positive, negative or neutral value?*

**In their ..... study, Lakhina, Crovella and Diot ....**

- |               |                |                |                   |                |
|---------------|----------------|----------------|-------------------|----------------|
| a) important  | e) small scale | i) interesting | m) ambitious      | q) significant |
| b) limited    | f) original    | j) rigorous    | n) useful         | r) traditional |
| c) modest     | g) exploratory | k) impressive  | o) preliminary    | s) remarkable  |
| d) innovative | h) flawed      | l) simple      | p) unsatisfactory | t) complex     |

(Adapted from: Morley, J. et al: University Writing Course, Express Publishing, Newbury, 2009, p.101)

**Task 2:** *Rewrite the sentences so that they are more accurate and precise.*

a) Such explosive children often need a combination of treatments to help them function better.

b) Multinational democracies, namely Belgium, Canada and Switzerland, are countries that follow federalist principles.

c) Herbivores that feed mainly or only on plants form an important link in the food chain.

(Adapted from: Robinson, M., Stoller, F. (2008): pp.594-596)

**Task 3:** Into the sentence below, insert the following words and expressions so they create a scale from the highest to the lowest level of probability.

a) possible    b) very probable / highly likely    c) certain    d) very / highly unlikely  
e) almost certain    f) unlikely    g) probable / likely

It is (1) ..... ► (2) ..... ► (3) ..... ► (4) ..... ► (5) ..... ► (6) ..... ► (7) ..... that where we find strong evidence of special design in nature, we should expect adaptation.

(Adapted from: Štěpánek, L., deHaaff, J., Hradilová, A.(2011): p.29)

## WORDS

**Task 1:** Do you do any concrete activities with a specific aim to improve your vocabulary? Discuss the question with your partner and share interesting points with the rest of the group.

**Task 2:** There are certain words and expressions to avoid in academic writing. Look at the list below and choose which ones you tend to avoid. Explain why.

indicate	data	truth	suggest
findings	examine	fact	reduce
determine	investigate	dramatically	figure
really	very	prove	fewer
research	good	to find out	actually

**Task 3:** Write five words you always use in your academic texts (do not mention articles, prepositions, connectors, numbers and pronouns). Compare your list with a colleague of yours.

**Task 4:** Work in groups. Write down as many reporting words as possible. They should be equivalents to the general word "say" you use in your writing.

## TITLE

*What is a title?*

*What are its characteristics?*

**A**

**B**

**C**

**D**

**Task 1:** *Read the following titles and decide which of them would be acceptable for an academic text. Justify your opinion.*

- 1) Ras isoforms vary in their ability to activate Raf-1 and phosphoinositide 3-kinase
- 2) Statistics for FCED in DS, LS and AS
- 3) Crystal structure of *Thermus aquaticus* DNA polymerase
- 4) A Study of Effects of H<sub>2</sub>O on structure of acid-catalysed SiO<sub>2</sub> sol-gel films

(Adapted from: 1,4, Glasman-Deal,H.,(2010), Science Research Writing for Non-native Speakers of English, Imperial College Press, London,); 2.Štěpánek, L., deHaaff, J.(2011): p.163-165; 3 <http://ukpmc.ac.uk/abstract/MED/7637814/reload=0;jsessionid=Sgv4gaMpwYRZU3u22PcY.6>)

**Task 2:** *Read the following titles and analyse their informative value.*

- 1) Molecular Cancer
- 2) What's the matter?
- 3) Semi-continuous nanofiltration-coupled Heck reactions: A new approach to improve productivity of homogeneous catalysts?
- 4) An Investigation in General Problems and Fundamental Issues: What is More Important

(Adapted from: Glasman-Deal,H.,(2010); Štěpánek, L., deHaaff, J.(2011): p.163-165)

**Task 3:** *Present a title of your own text and discuss it with your colleagues.*

## SENTENCES

**Task:** *Analyse the quality of the following sentences.*

a) Since it was, as mentioned, a test, we did not try to achieve the best results, we wanted to verify the idea of time characteristics.

b) Common types of DNA damage that interfere with replication fork progression are chemical modifications (adducts) of DNA bases, which are created by reactive drugs that covalently bind DNA either directly or after being metabolized in the body and are grouped in two categories: monofunctional alkylating agents with one active moiety that modifies single bases and bifunctional alkylating agents that have two reactive sites and crosslink DNA with proteins or, alternatively, crosslink two DNA bases within the same DNA strand (intra-strand crosslinks) or on opposite DNA strands (inter-strand crosslinks), which pose a severe block to replication forks.

c) To avoid the decomposition of the diazonium salt, the resulting solution was cooled to -5°C using an acetone-ice bath and then hypophosphorous acid and sodium nitrite slowly added.

(Adapted from: Štěpánek, L., deHaaff, J.(2011): Academic English, Grada, Praha, p.153)

This sentence has five words. Here are five more words.  
Five-word sentences are fine. But several together become monotonous. Listen to what is happening. The writing is getting boring. The sound of it drones. It's like a stuck record. The ear demands some variety.

Now listen. I vary the sentence length, and I create music. Music. The writing sings. It has a pleasant rhythm, a lilt, a harmony. I use short sentences. And I use sentences of medium length. And sometimes when I am certain the reader is rested, I will engage him with a sentence of considerable length, a sentence that burns with energy and builds with all the impetus of a crescendo, the roll of the drums, the crash of the cymbals—sounds that say listen to this, it is important.

So write with a combination of short, medium, and long sentences. Create a sound that pleases the reader's ear. Don't just write words. Write music.

-Gary Provost

## PARAGRAPHS

The paragraph, the most important unit of academic writing, is “a physical unit within a text that is concerned with one topic or an aspect of a topic or that serves as a transition between complex points” (Beene, 1992). The average paragraph in English, according to research, is five to ten sentences, with 75 to 150 words.

A paragraph contains two or more sentences that develop one subject logically. The logic of paragraph development varies from cultural area to cultural area. In English, logic calls for direct development. Begin with the exact subject, develop the subject directly with examples and facts, and end with a summarizing sentence (that may lead into the following paragraph). A paragraph in English may be inductive or deductive.

A deductive paragraph has three parts: the topic (first) sentence (the major premise); development of the subject in three to eight sentences (minor premises connected to the major premise), and a one-sentence summary at the end (conclusion). An inductive paragraph has two parts: the topic sentence, which presents an example or observation (or premise); additional sentences that add other examples or observations (or premises), and a conclusion based on summing up the examples. While there is a place for inductive paragraphs, the most commonly used form in English academic writing is the deductive paragraph.

The Topic Sentence, or first sentence of each paragraph, communicates the subject of the paragraph by giving the reader the general subject and the specific parts of the general subject that will be developed in the paragraph. The specific parts of the topic sentence organize the subject development; they introduce the order of topics within the paragraph. Some paragraphs have only the topic sentence and sentences that support it; in other paragraphs the focus narrows as each sentence picks up only one point from the preceding sentence. Examples in the paragraph should be as specific as possible. The final sentence of the paragraph summarizes the content. This sentence may either repeat the main ideas of the paragraph in a new way or give a conclusion based on the information in the paragraph.

(Adapted from: George M. Rooks, *Paragraph Power; Communicating Ideas Through Paragraphs*, 2d ed., (White Plains, NY: Pearson Education, 1999)

**Task:** Choose the best among the four **topic sentences** given for the paragraph below.

- 1) There are three major differences between a thesis and a dissertation.
- 2) Although originality and significance provide some basis for distinguishing a thesis from a dissertation, other qualities need to be considered.
- 3) Despite having different names, a thesis and a dissertation are, in fact, very similar in most respects.
- 4) It is reasonable to expect that various types of texts, namely essays, theses, and dissertations, share a wide range of common features.

..... First, both are expected to follow principles of sound research design and implementation. Both also follow the same principles of good academic writing style and are written up in much the same way, sharing as they do similar structure, organisation and formatting conventions. Finally, both require you, as a researcher, to produce a piece of work that is original and adds to the body of knowledge in the field with which your research is associated. (Murray, Beglar, 2009:3)

## ABSTRACTS

*What are abstracts and why do we write them?*

*Abstracts have a fairly standard form. Which essential parts should an abstract consist of?*

**Task 1:** *Read the abstract below and identify its parts. Identify words or groups of words in each sentence that help you to recognise those parts.*

**(1)** The present study was conducted to determine the prevalence of *Listeria monocytogenes* in smoked fish in Sokoto, Nigeria. **(2)** A total of 115 different species of smoked fish from the various retail outlets and market places within the metropolis were analysed for the presence of *L. monocytogenes* using ISO culture method. **(3)** Out of the 115 samples analysed, 29 (25%) were positive for *L. monocytogenes*. **(4)** Other *Listeria* species isolated in this study were *L. grayi* 13 (11%), *L. innocua* 10 (9%) and *L. ivanovi* 15 (13%). **(5)** The remaining 48 (42%) of the sample were negative for *Listeria* species. **(6)** The study shows that *L. monocytogenes* and other *Listeria* species are common contaminant of smoked fish, and this may pose serious public health implications. (Salihu et al., 2008)

(Adapted from: Štěpánek, L., deHaaf, J., Hradilová, A.(2011): p.172)

**Task 2:** *Suggest changes that will reduce the length of this abstract (208 words) to the requested maximum of 200 words:*

Given the demand for interventions that may prevent the development of persistent musculoskeletal pain problems, we investigated the effects of a cognitive-behavioural program in a group of non-patients with neck or back pain symptoms. Two hundred and fifty-three people selected from a population study were invited to participate. These people had experienced four or more episodes of relatively intense spinal pain during the past year but had not been out of work more than 30 days. Participants were randomly assigned to either a cognitive-behavioural group intervention or a treatment as a usual comparison group. The experimental group received a standardized six-session program, provided by a trained therapist according to a manual. A significant overall analysis at the 1-year follow-up showed that the cognitive-behavioural group produced better results on 26 of the 33 outcome variables. Group comparison indicated that the cognitive-behavioural group, relative to the comparison group, had significantly better results with regard to fear-avoidance beliefs, number of pain-free days, as well as the key variable of sick leave. Participation in the cognitive behavioural group reduced the risk for long-term sick leave during the follow-up by threefold. Thus, despite the strong natural recovery rate for back pain, the cognitive-behavioural intervention produced a significant preventive effect with regard to disability.

(Linton & Ryberg, 2000)

## TEXT STRUCTURE

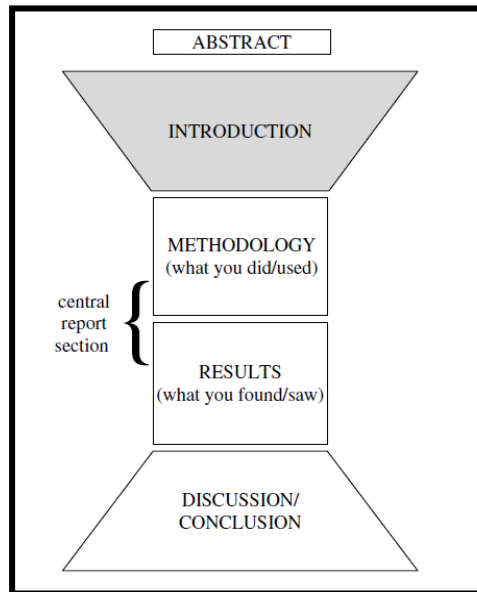

**Task 1:** Match the words and phrases in 1-5 with the sub-headings they have been taken from.

a) acknowledgements    b) introduction    c) methods    d) results    e) discussion

**1)** *The experiments were conducted at a temperature of 0.5°C.  
...was used to measure ...*

*The same samples were retested at a two-week interval ...*

**2)** *...exhibited a significantly lower binding potential relative to ...  
In general, the experimental samples resisted ...*

*A considerable amount of residue remained in the pipe.*

**3)** *I am (most/very) grateful to ...*

*This paper could not have been written without the invaluable help of ...*

*I acknowledge my gratitude to ...*

**4)** *However, the findings do not imply...*

*From this data, it is clear ...*

*As has been proved, the theory may have practical importance for ...*

**5)** *The main purpose of the experiment reported here was to ...*

*Recently there has been considerable interest in ...*

*The aim of this paper is to give ...*



**Task 2:** Look at the steps which frequently appear in research article or thesis sections I-M-R-D/C. Identify each section and discuss the importance of the presented steps in your field.

1.           **a)** providing a general introduction and overview of the materials/methods  
**b)** restating the purpose of the work   **c)** giving the source of materials/equipment used  
**d)** justifying choices made   **e)** providing specific and precise details about materials and methods   **f)** supplying essential background information   **g)** indicating that appropriate care was taken   **h)** relating materials/methods to other studies   **i)** indicating where problems occurred

2.           **a)** revisiting the research aim/existing research   **b)** revisiting/expanding methodology  
**c)** general overview of results   **d)** invitation to view results   **e)** explanations  
**f)** specific/key results in detail, with or without   **g)** comparisons with results in other research  
**h)** comparison/s with model predictions   **i)** problems with results  
**j)** possible implications of results

3.           **a)** revisiting the main idea / purpose of the text   **b)** revisiting previous sections  
**c)** summarising/revisiting general or key results   **d)** mapping relationship to existing research  
**e)** achievement / contribution   **f)** refining the implications   **g)** limitations  
**h)** current and future work applications

4.           **a)** announcing present research   **b)** announcing principal findings   **c)** claiming centrality  
**d)** continuing a tradition   **e)** counterclaiming   **f)** indicating a gap   **g)** indicating RA structure  
**h)** making topic generalization   **i)** outlining purposes   **j)** question-raising  
**k)** reviewing items of previous research

**Task 3:** Look at the table and discuss the options and their frequency in your field or research.

Option 1	Option 2	Option 3	Option 4
Results <i>or</i> Data Analysis	Results <i>or</i> Data Analysis	Results and Discussion	Results <i>or</i> Data Analysis
Discussion	Discussion	∅	Discussion and Conclusion(s)
Conclusion(s)	∅	Conclusion(s)	∅

**Task 4:** Choose the most suitable word for the “Introduction” section in the academic context.

- a) The purpose of this study **IS – WAS – WILL BE** to develop concepts to describe, conceptualise and analyse the emerging software component market from the point of view of the industrial buyer.
- b) However, light scattering techniques **WERE – HAVE BEEN – ARE BEING** largely unsuccessful to date.
- c) **MANY – MUCH – A LOT OF** research in recent years has focused on the synthesis, characterization and properties of metastable materials..
- d) It is **OPTIMALLY – OFTEN – GENERALLY** accepted that egg and larval quality are partly controlled by material diet.
- e) Pancreatic ductal adenocarcinoma (PDA) accounts for **SOME – OVER – ABOVE** 95% of all pancreatic cancers.

**Task 5:** Read the sentences from a “methodology section” below and explain the expressions in bold.

- a) **For the sake of simplicity**, only a single value was analysed.
- b) They were then placed on ice for **immediate** analysis.
- c) A mechanical fixture was employed to hold the sonic horn **firmly** in place.
- d) **Frequent** pattern mining has been a focused theme in data mining research for over a decade.
- e) After being removed, the mouse lungs were frozen and thawed **at least** three times.
- f) The specimen was monitored **constantly** for a period at 24 hours.
- g) The samples were **slowly and carefully** sheared to failure.

**Task 6:** Read the groups of sentences from a “result section” below and explain the difference in their meanings.

**(a<sup>1</sup>)** We found that the pressure **increased** as the temperature **rose**, which **indicated** that temperature **played** a significant role in the process.

**(a<sup>2</sup>)** We found that the pressure **increases** as the temperature **rises**, which **indicates** that temperature **plays** a significant role in the process.

**(b<sup>1</sup>)** The temperature increased to 49°C **and then** dropped to 30°C.

**(b<sup>2</sup>)** The temperature increased to 49°C **but soon** dropped to 30°C.

**(b<sup>3</sup>)** The temperature increased to 49°C **and later** dropped to 30°C.

**(c<sup>1</sup>)** The temperature dropped sharply when we reduced the pressure.

**(c<sup>2</sup>)** At the end there was a noticeable drop in temperature.

**(d<sup>1</sup>)** As can be seen in Fig. 1, the effect occurred **in** 23% of cases.

**(d<sup>2</sup>)** As can be seen in Fig. 1, the effect occurred **in as many as** 23% of cases.

**(d<sup>3</sup>)** As can be seen in Fig. 1, the effect occurred **in only** 23% of cases.

## PROCESSES

Planning diagram

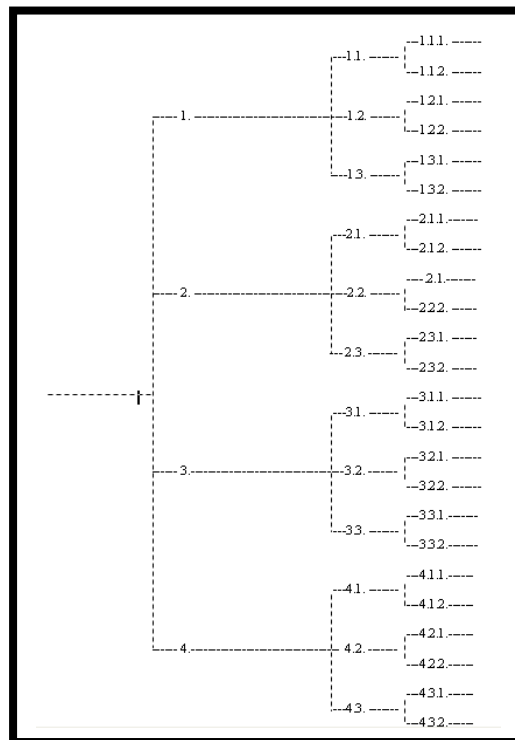

**Task 1:** Choose a verb for your paper.

The aim of this paper is to ....

**Task 2:** Brown's 8 questions: Write for 30 minutes on the subject of your journal article.

- |  |                                     |
|--|-------------------------------------|
| 1. Who are the intended readers?               | List three to five of them by name. |
| 2. What did you do?                            | 50 words                            |
| 3. Why did you do it?                          | 50 words                            |
| 4. What happened and when you did that?        | 50 words                            |
| 5. What do the results mean in theory?         | 50 words                            |
| 6. What do the results mean in practice?       | 50 words                            |
| <b>7. What is the key benefit for readers?</b> | <b>25 words</b>                     |
| 8. What remains unresolved?                    | no word limit                       |

## **ACADEMIC PRESENTATIONS**

What makes a good presentation? (What makes a bad presentation?)

What makes a presentation academic?

**Task:** *Work in groups. Name all parts of the presentation process that you believe form a necessary (or unavoidable) part for a successful presentation.*

### **TIME MANAGEMENT**

*What is the relation between the length of a presentation you are going to give and the preparation time?*

*How do you organise your time when preparing a speaking task?*

### **TOPIC**

*Can you choose topics of your presentations or are you usually given one?*

### **AIMS and OBJECTIVES**

*Discuss the purpose statements below.*

## **AUDIENCE ANALYSIS**

*What should you know (in an ideal case) about your future audience? Why?*

## **RESEARCH**

*Discuss your selection of information.*

## **PREPARING NOTES**

*What type of notes do you use and why?*

## **REHEARSAL**

*Why?*

*How many times?*

*How?*

## **INTRODUCTIONS**

GREETING

POSITIVE COMMENT

NAME

POSITION

TOPIC / TITLE / SUBJECT

PURPOSE

OUTLINE

TIME

AUDIO-VISUAL AIDS

QUESTIONS

**Task:** Use one of the following expressions to replace each of the expressions in bold in this introduction.

- |                   |                  |
|-------------------|------------------|
| a) don't hesitate | f) divide        |
| b) a chance       | g) go through    |
| c) I take care    | h) in more depth |
| d) I'm delighted  | i) My purpose is |
| e) sections       | j) finally       |

Hello, everyone. May I have your attention, please? OK. Thank you for coming. (1) **It's a pleasure** to be with you today. My name is Sheila Turner and (2) **I'm in charge** of the Study Skills Support here, at the Learning Centre. (3) **We are here today** to (4) **review** some key principles and to give you information about managing your time here at university. So what I intend to do is to (5) **break down** this presentation into three (6) **parts**. First, we will identify how one's relationship with time can effect a person's time management; second, we'll have a look at balancing one's time, and (7) **third**, we'll talk about efficient and effective time management strategies. If you have any questions, please, (8) **feel free** to interrupt me, but I should also say there'll be (9) **an opportunity** to discuss everything (10) **at greater length** after my talk.

**Task** Prepare an introduction that will include all the structural points from above. Work in pairs. Present the introduction in less than 50 seconds. If your speech takes longer, reformulate, change or leave some ideas out and try again.

(Adapted from: Štěpánek, L., deHaaff, J., Hradilová, A.(2018): Academic English, Grada, Praha)

## **MAIN BODY**

STYLE

STRUCTURE

TRANSITIONS / SIGN POSTING LANGUAGE

## **ENDING**

SIGNAL TO END

SUMMARY

CONCLUSION

CLOSE

INVITATION FOR QUESTIONS

**Task:** Complete the following concluding section with words from the list.

- |              |                 |               |
|--------------|-----------------|---------------|
| a) comments  | e) insight      | i) that's all |
| b) To sum up | f) considered   | j) namely     |
| c) tasks     | g) On the whole | k) therefore  |
| d) listening | h) papers       | l) points     |

Well, (1) ..... I wanted to tell you today. I hope that has given you a reasonable (2) ..... into the area of language competence needs. (3) ..... the most important (4) ..... . First we looked at the (5) ..... and genres identified for the academic sphere, such as lectures, team work, presentations, or academic (6) ..... . Then we (7) ..... activities and genres identified for the professional sphere, (8) ..... interviews, negotiations, reports, social events, emails and commercial documents. (9) ....., I'd like to emphasise that despite the theoretical distance between the academic and professional worlds, the language competencies people need in both spheres are more or less the same and (10) ..... there is no reason why students good at communication in foreign languages at university should not be excellent communicators in their professional careers. Thanks for (11) ..... and if you have any questions or (12) ....., I'll be happy to answer them.

(Adapted from: Štěpánek, L., deHaaff, J., Hradilová, A.(2011): Academic English, Grada, Praha, pp.124-125)

## **AUDIO-VISUAL AIDS**

*What audio-visual aids do you use and why?*

*What are their advantages and disadvantages?*

## **QUESTIONS**

*How to prepare?*

## **DELIVERY**

VOICE

BODY LANGUAGE



## **CHAIRING A SESSION**

**Task:** *Read the expressions below and comment on their quality. Think of their equivalents.*

Can you, please, welcome Ms. Stone.

Just raise your hand and I ask you to give your name and institution.

OK, first we've got Andrew who needs no introduction from me. And we are visiting CARELTS, I am sure you will tell us more about that as you go on. OK, thank you. Do you want to start?

I am afraid, there are not enough handouts for everybody but I think sharing is a good opportunity to make friends.

Welcome back everybody. Have you refreshed and reinvigorated?

I am not going to introduce the speakers as you want to hear them speaking not me speaking about them.

Ladies and gentlemen, welcome to this session in our afternoon programme. Some household first.

In the interest of time we need to move on.

Just wave your hand and say your name and institution.

Welcome to the first of the parallel session. The system we have got this year is that there are breaks between papers, so if you want to go off and go to another one you are not stuck in this stream. Allan and Michelle would be very happy if you stayed but there is not obligation to stay for the whole three. So we've got five minutes between each session for you to go and find other things to do if you want to.

Ok, welcome everybody to this presentation on Media and I really must thank Rosalind and Marta for the last presentation because it was strikingly similar in context to what we are going to hear now.

OK, I will be chairing this afternoon session in this track or strand. The three papers in this session, and, in fact, in all of the sessions, are 30 minutes long and that will generally comprise of 20 minutes of presentation and hopefully 10 minutes or so for questions from the audience.

In order to make sure to be fair on those that are presenting subsequently to have time to change over, but also for those of you who may wish to go to a different strand or those who wish to come to a strand in mid-session, I am going to try to be fairly strict on time. So, that is for the presenters and also for the audience, so we will try to keep to the half hour slot. So this should give an opportunity to move to another session if you need to and for others to arrive.

I think that's all I need to say. Except when it comes to question time because all of this is being recorded, if you can indicate clearly that you want to ask a question, once my colleague here has decided who he is selecting for a question, I will then pass the microphone to you so that everybody can be heard clearly but also so that it's been recorded as well.

So I am about one minute late. It gives me a great pleasure to introduce Martin Lawson from the University of Cumbria, UK. Over to you Martin.

This is the final paper of today's session; we are going to try to stick carefully to time because we want to give you the opportunity to get to the keynote at 25 past. After which there is the surprise and then fun on the beach.

OK. This is the last one, I think, this is the last session. I would like to introduce Rita Hejtoff. And Rita is going to talk about ..... . Over to you.

Chris is here from the University of Leicester. And it is great because he is here, he is in the right place and he is on time. Well done, Chris, thanks for that. OK, so Chris is going to be talking about – well, you can see it on the board – ..... and some other stuff.

That is an interesting day today. The last speaker went to the wrong room and we were all here and he was somewhere else looking for us. Quite interesting he finished exactly on time. Right, this is, let me introduce Peter Roy, who comes from deepest Dorset in UK and he is going to talk to us about .....

Ladies and gentlemen, let me introduce Ian Huglop, who is going to talk about his personal experience with ....

The problem we've got is that we have to finish at 9:30 or at 9:35 at latest, there is another speaker in here and there is another speaker downstairs which I have to be there for, so you're gonna have to be a little bit quicker, if that's all right....