

The Impact of Discount Rate on Commercial Rates in the Czech Republic: The Cybernetic Approach

František Kalouda¹

¹ Masaryk University

Faculty of Economics and Administration, Department of Finance
Lipová str. 41a, 602 00 Brno, Czech Republic
E-mail: kalouda@econ.muni.cz

Abstract: *The paper is devoted to the Czech banking system identification as a cybernetic system. The behaviour of banking system defined in this way is analysed here in the branch of capital cost management (bank loan). The aim of the paper is analysis of the managing system relations (regulator – central bank) to managed system (regulated cadre – commercial banks) as relationships between operational indicator (discount rate) and regulated indicator (commercial rates). The analysis encompasses the study of research time periods choice influence on research results. The main results of the paper are working conclusions related to structure and to behaviour of the Czech banking system as cybernetic system too and to impacts of structure and of such system behaviour on cost of capital management.*

Keywords: banking system, cybernetics, cost of capital

JEL codes: C67, E58, G21, G32

1 Introduction

Even the importance of bank loan has partly decreased in favour of the “newly entering ones” (Johnson and Scholes, 1989), the bank loan is in the Czech Republic still the most important companies financial resource (Kalouda and Málek, 2009). Its basic parameter is price, i.e. market interest rate (Revenda, 1999).

There is still the opinion between the financial theorists that the market interest rate is highly influenced by the central bank and by its discount rate. “Discount rate ... designates ... the price of loans in an economy. ... Staying in the loans branch, we are able to identify six main interest rates, resp. interest measures” (Revenda, 1999). Further, we will consider discount rate and market interest rate from these six interest rates.

According to Revenda, Z. (1999) „The main aim of discount rate changes ... caused by central bank ... is affection of movement, resp. of other interest rates level in economy and therefore influence on subjects’ loans demand.”. These central bank tendencies are in market economies quite analogic. This fact can be supported by an example from the USA “... as the instrument of FED serves **discount rate** – that is interest rate related to loans granted by FED to banks.” (Mankiw, 2000).

The ambiguity of discount rate effects known from theory can on one side lead to extreme, when “Problematic discount rate changes impressions ... on banks behaviour are the main reason why these rates are in many countries changed only slightly and in longer time periods.” (Revenda, 1999). On the other side in different circumstances “... banks ... react on changes of (primarily) discount rate very sensibly. Sometimes it is not necessary to change this rate but it is sufficient that the central bank will convey ... deciding about discount rate change. The reaction is almost the same We speak about the *announcement effect* of discount rate” (ibid).

This ambiguity of discount rate influence on market interest rate is the main motive for this paper creation. The main aim of the paper is therefore the analysis of discount rate

impact on market interest rate. To reach this aim there will be investigated following problem areas:

- fundamental applicability of cybernetic approaches in selected area
- rationality of the Czech banking system structure recognized as cybernetic system
- linearity of the Czech banking system
- overstability of the Czech banking system
- regulation accuracy of the Czech banking system.

2 Methodology and Data

The discount rate influence on market interest rate is in this paper conceptualized in general terms as a problem of communication and of management. Therefore it is suitable to apply methodical apparatus of theoretic discipline in these terms that was in the Czech Republic used for these intensions only marginally. This theoretic discipline is "cybernetics ... as a science about general laws of origination, transmission and processing of information in complex systems and about general principles of these systems management." (Kubík et al., 1982).

From these methodical instruments of cybernetics (more exactly of technical cybernetics) there will be further used:

- static function (Kubík et al., 1982),
- step function response (Kubík et al, 1982), resp. Švarc (2003) and
- theory of hysteresis function (Švarc, 2003).

For the purposes of verification (including visualization) of step function response there will be from the applied mathematics apparatus used:

- theory of differential equations, especially in the form of
- Laplace transform.

As parts of the paper methodical apparatus are except above mentioned techniques also used description and common analytically-synthetic procedures.

In data and results presentation there are the graphic outcomes preferred because of the data extent. The paper is based on publicly available entry data http://www.cnb.cz/cs/financni_trhy/penezni_trh/pribor/rok_form.jsp which are (because of range reduction) cited here. These data cover time period from 31st January 2004 to 30th August 2013.

3 Results and Discussion

Fundamental applicability of cybernetic approaches in the selected area

The source Allen (1971) emphasizes in these terms unequivocal opinion: „There is necessary only the formal similarity to anticipate that the methods used in technics will be suitable for economic models too.“ This condition is met in our case.

Nevertheless, the same source mentions an important problem with application of methods that have been successfully proved in technical sphere on the economic sphere – the linearity of the models. „Linear models can be generally suitable for technics where everything can be accurately managed. Be sure that they are not suitable up to the same extent for the economic models.“ However, there is accepted the possibility of linearization.

Rationality of the Czech banking system structure recognized as cybernetic system

The study of this phenomenon brought the first and striking result. For its relevant interpretation there will be firstly described the concept of control loop in its classical form (see Figure 1).

Figure 1 The classical scheme of control loop

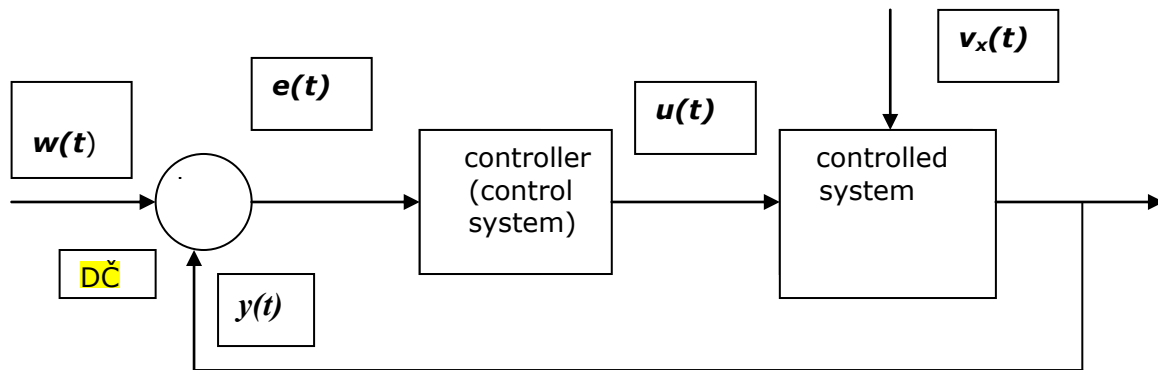

Legend:

- | | | |
|----------------|----------------------------------|--|
| $w(t)$ | command variable | - unknown indicator, it cannot be interpreted |
| $e(t)$ | error | - - " - |
| $u(t)$ | manipulated variable | - discount rate |
| $v_x(t)$ | disturbance variables | - are recognized as a part of ceteris paribus assumption |
| $y(t)$ | controlled variable | - commercial rate / rates |
| DČ | differential element ($e=w-y$) | - unknown component, it cannot be defined |

Source: Adapted from Švarc et al. (2011, pp. 62-65).

Modification of the classical scheme of control loop for the influence of central bank official independence is obvious (see Figure 2). The system feedback is preserved indeed but its ability of target behaviour is in absence of command variable $w(t)$ at least disputable.

Figure 2 The modification of control loop – consequence of central bank independence

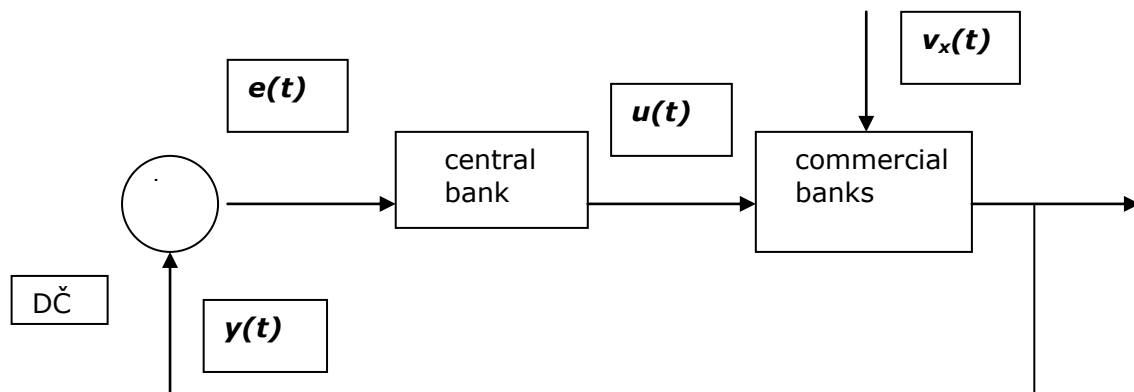

Source: Own construction of the author based on Švarc et al. (2011, pp. 62-65).

It is even possible to express more radical conclusion – entire absence of command variable makes this control loop dysfunctional. That is the reason why there arises the obvious need to substitute the officially non-existent command variable by its equivalent. That is probably possible in the form of informal organizational structures built in the Czech banking system as well as beside it. It is in interesting way proved by typing error of the source (Revenda, 1999). „The main aim of discount rate changes ... from the side of central bank (government) is to influence progression, resp. the level of other interest rates ... and therefore to affect the demand ... for loans.“

Linearity of the Czech banking system – static function of commercial banks

“Static characteristics of control members are mostly expressed by the static function, i.e. the dependence between the output indicator in stabilized state and entry indicator in stabilized state.” (Švarc, 2003). That means the values constant for our purposes during the time period long at least six months. It is obvious that the system of commercial banks can be with acceptable inaccuracy rate recognized for linear (see Figure 3).

For comparison – dependence quite same in type is presented as a linear one in source Balátě (2004) too.

Figure 3 Static function of commercial banks

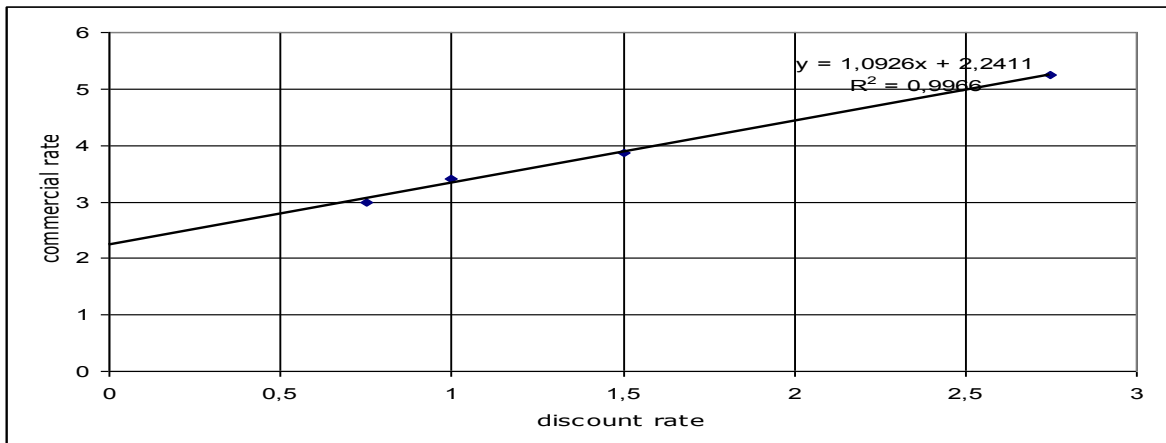

Source: Own construction of the author

Static accuracy of the Czech banking system – step function response of commercial banks

Step function response is constructed on the basis of above mentioned “second cycle” data. More closely it is spoken about the data from the time period between 31st January 2004 and 30th August 2013. Related step of entry indicator (discount rate) is the change from value 0.75 % to 1.00 %.

Figure 4 Step function response of commercial banks

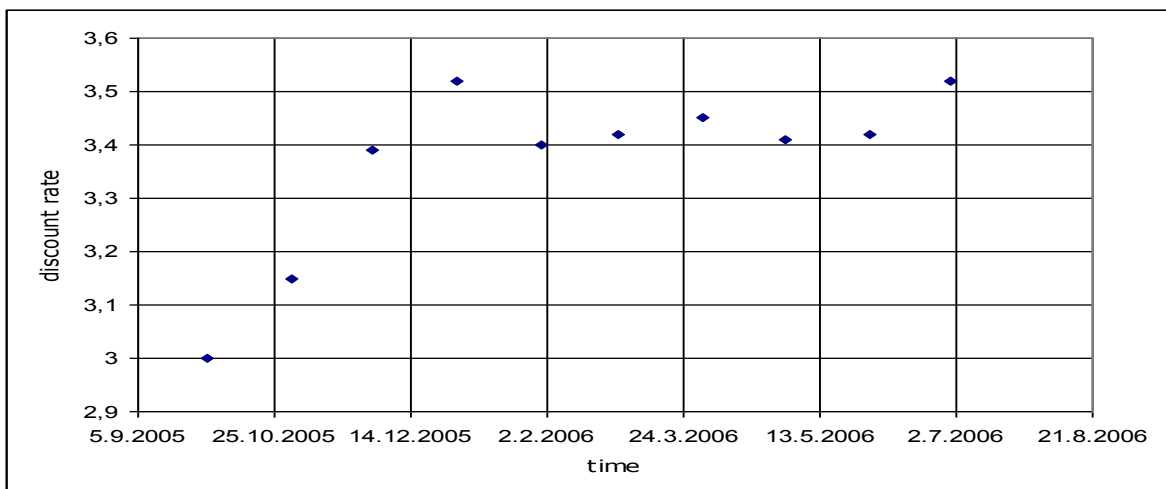

Source: Own construction of the author

Expert evaluation of data in Figure 4 leads us to working conclusion that the commercial banks represent in fact locally stable static oscillating system of second order.

Verification of the assumption according to selected methodology (Fikar and Mikleš, 1999) can be seen in Figure 5. This methodology constructs correspondent differential equation of system transmission in heuristic way and it uses the values that were empirically gained from the transition function (dashed line).

Figure 5 The verification of the step function response of commercial banks

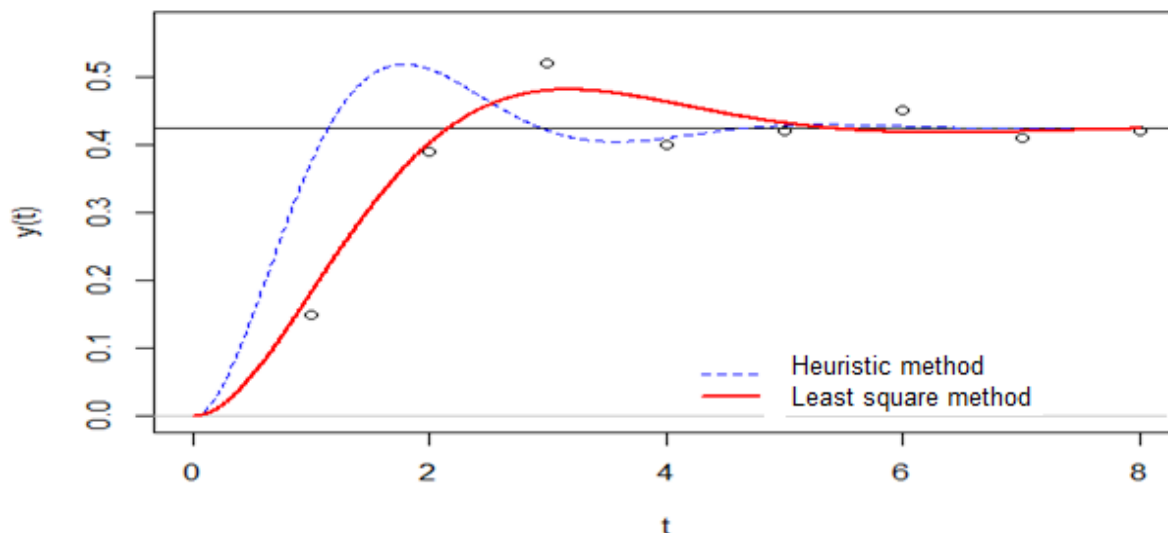

Source: Bíza (2014). Working paper (SVA outcome) in the framework of OP VK project "Věda a vědci pro vzdělanost moderní společnosti" (CZ.1.07/2.3.00/35.0005), unpublished work, FEA MU, May 2014.

In Figure 5 there is presented also the result of alternative methodology application, i.e. least square method (full line). Outcomes of this methodology are more reliable than the above described heuristics. Deeper discussion of this phenomenon is, unfortunately, beyond the borders of this paper.

However, it is necessary to consider that both mentioned constructions do not take into account the last gained data that could be recognized as the exposure of system tendency to start unstable vibrate. This problem will need further more detailed analysis of accessible data.

Regulation accuracy of the Czech banking system (central bank and commercial banks)

Interaction between central bank and commercial banks leads to negative synergies when there occurs the non-linearity of the hysteresis type (see Figure 6). This state eventuates in conclusion that announcement effect of discount rate consecutively erodes. In its implications it means that after certain cycles number of "increase-decrease" type the discount rate will lose its ability to regulate commercial rate.

Figure 6 The hysteresis erosion of discount rate announcement effect

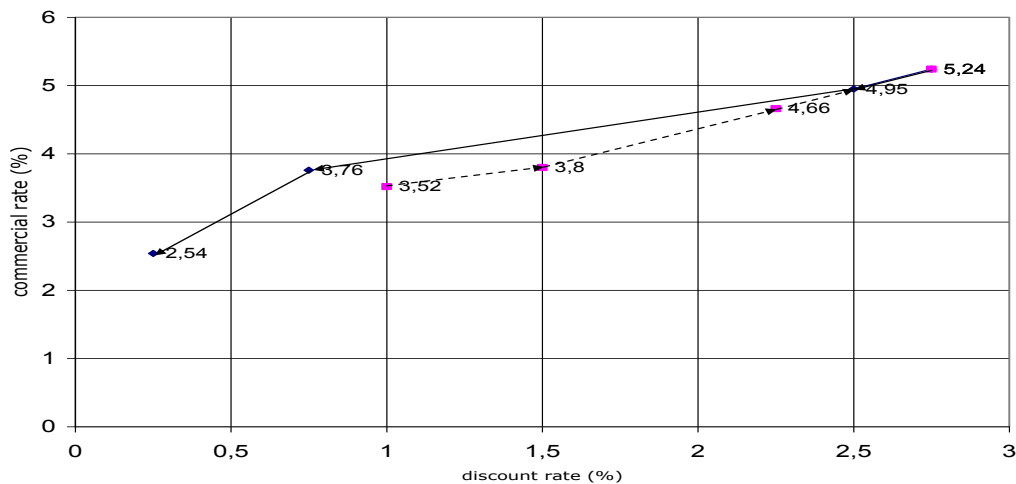

Source: Own construction of the author

4 Conclusions

The paper conclusions are formulated in relation to above mentioned structure of partial analysed problem areas. With consideration of theoretic knowledge and according to stated available data processing there can be on the discussion basis formulated succeeding paper conclusions:

- fundamental applicability of cybernetic approaches in selected area

Cybernetic approaches are for the settled task (inquiry into economic processes) undoubtedly utilizable. The possible problems with disputable linearities can be in the first approximation solved by linearization of tackled problem. The methodology of non-linear regulation can be used in well-founded cases.

- rationality of the Czech banking system structure recognized as cybernetic system

The assumption of central bank independence leads to absence of command variable $w(t)$. The Czech banking system appears at this state of affairs as the system with feedback but in fact as the uncontrolled system. The possibilities of rational target behaviour are in this case quite limited.

- linearity of the Czech banking system – static function of commercial banks

Commercial banks conduct themselves as a linear system in principle. The rate of the current identifiable nonlinearities is so low that the linearization does not bear any major problems.

- static accuracy of the Czech banking system – step function response of commercial banks

Step function response of commercial banks leads to partial conclusion that the commercial banks can be from dynamic view perceived as locally stable static oscillating system of second order. However, accessible data do not exclude tendencies to non-stationary oscillations with the risk of potential system destabilization.

- regulation accuracy of the Czech banking system (central bank and commercial banks)

The nonlinearity of hysteresis type is typical for coexistence of central bank with commercial banks. The consecutively erosion of discount rate announcement effect is a

result of this state. It can even lead to loss of applicability of discount rate as cost of capital (bank loan) management instrument at the level of commercial rate. Present level of discount rate confirms this theoretic possibility in praxis.

The paper results are surprising in a certain manner. They can raise fears concerning banking system stability. In addition they theoretically confirm limited possibilities of discount rate as an instrument for regulation of cost of capital in the form of bank loan (market interest rate). In this relation there can be clearly seen possible similarity with the monobank management potential (Kalouda and Svítíl, 2009), (de SOTO, 2009) even if there are taken into account all disadvantages resulting from this variant of banking sector organizational order (Revenda, 1999).

Acknowledgments

This article is one of the research outputs of the OP VK project "Věda a vědci pro vzdělanost moderní společnosti" (CZ.1.07/2.3.00/35.0005).

References

- Allen, R.G. (1971). *Matematická ekonomie*, Praha: ACADEMIA.
- Balátě, J. (2004). *Automatické řízení*, Praha: BEN.
- Bíza, M. (2014). Working paper (SVA outcome) in the framework of OP VK project "Věda a vědci pro vzdělanost moderní společnosti" (CZ.1.07/2.3.00/35.0005), unpublished work, FEA MU, May 2014.
- Fikar, M., Mikleš, J. (1999). *Identifikácia systémov*. Bratislava, STU Bratislava. http://www.cnb.cz/cs/financni_trhy/penezni_trh/pribor/rok_form.jsp
- Johnson, G., Scholes, K. (1989). *Exploring corporate strategy: text and cases*. Hemel Hemstead, Prentice Hall International (UK)
- Kalouda, F., Málek, P. (2009). Alternativní zdroje financování – outsideři v útoku? (The Alternative Financial Resources – Outsiders on the Offensive?). In.: Vybíhal, V., ed., *Nové trendy – nové nápady*. Znojmo: SVŠE Znojmo, pp. 452-459.
- Kalouda, F., Svítíl, M. (2009). The Commercial Bank such as the Cybernetic System in Conditions of the Global Financial Crisis. In.: *Management, Economics and Business Development in European Conditions*, Brno, FP VUT, pp II.24-II.31.
- Kubík, S., Kotek, Z., Strejc, V., Štecha, J. (1982). *Teorie automatického řízení I, Lineární a nelineární systémy*, Praha: SNTL.
- Mankiw, N. G. (2000). *Zásady ekonomie*, Praha: Grada Publishing.
- Revenda, Z. (1999). *Centrální bankovnictví*. Praha: MANAGEMENT PRESS.
- SOTO de, J. H. (2009). *Peníze, banky a hospodářské krize*, Praha: ASPI a Liberální institut
- Švarc, I. (2003). *Teorie automatického řízení*, Brno, FS VUT.
- Švarc, I., Matoušek, R., Šeda, M., Vítečková, M. (2011). *Automatické řízení, 2nd ed.* Brno: CERM.



INVESTICE DO ROZVOJE VZDĚLÁVÁNÍ